

MODEL : DU-141H-6(AK-44A/AK-44B)/DSU-145-6(AK-44A/AK-44B)  
List No : 0559-00

# PARTS LIST

Published:05/12/2017

## CONTENTS

---

AK-44 A TYPE.....	1
AK-44 B TYPE.....	3
HOW TO MAKE USE OF THIS PARTS LIST .....	5

AK-44 A TYPE

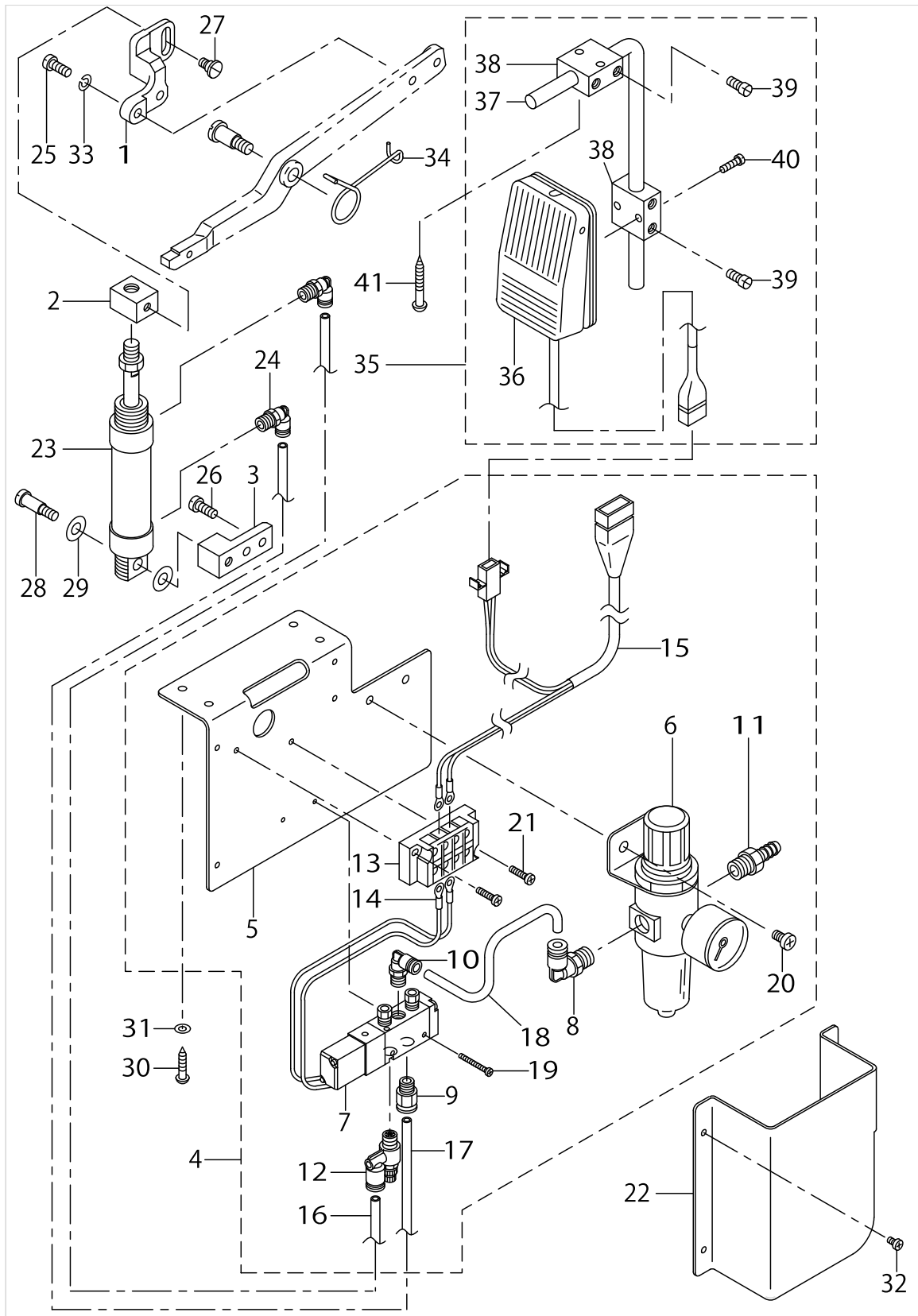

AK-44 A TYPE

No.	Supply Code	Parts No.	Replacement	Parts name	Remarks	Choice	Step	Level	Cons	Qty	Rep. QTY
1		GAK44001000		AUTOMATIC LIFTING ARM						1	
2		GAK29003000		CYLINDER BLOCK						1	
3		GAK44002000		CYLINDER BASE						1	
4	D	GAK290010A0		PNEUMATIC UNIT						1	
5		GAK29001000		SOLENOID VALVE MOUNTING PLATE				*		1	
6		GAK29007000		FILTER REGULATOR				*		1	
7		GAK29008000		SOLENOID VALVE				*		1	
8		GAK29009000		ELBOW				*		1	
9		GAK29015000		JOINT A				*		1	
10		GAK29010000		ELBOW B				*		1	
11		GAK29011000		NIPPLE				*		1	
12		GAK29016000		SPEED CONTROLLER				*		1	
13		GAS11419000		TERMINAL BASE				*		1	
14	D	HP001330000		CONNECTOR				*		2	
15		GAK020210A0		PRESSER LIFTING CORD ASM.				*		1	
16		BT0600401EB		TUBE				*		1.2	
17		BT0600401EB		TUBE				*		1.1	
18		BT0600401EB		TUBE				*		0.1	
19		SM4032501SB		SCREW M3X0.5 L=25.0				*		2	
20		SM4061001SB		SCREW M6 L=10				*		2	
21		SM4041601SR		SCREW M4 L=16				*		2	
22		GAK29002000		SOLENOID VALVE COVER						1	
23	R	GAK29013000	PA2502503A0	CYLINDER						1	1.00
24		GAK29010000		ELBOW B						2	
25		SS6151440SP		SCREW 15/64-28L=14						2	
26		SS6151440SP		SCREW 15/64-28L=14						2	
27		SD0790433TP		HINGE SCREW D= 7.94 H= 4.3						1	
28		SD0801601SP		HINGE SCREW D= 8 H=16						1	
29		WP0850002SP		WASHER 8.5X18X1.6						2	
30	R	SK3482500SC	SK3482501SE	WOOD SCREW D=4.8 L=25						4	1.00
31		WP0501016SC		WASHER 5X10.5X1						4	
32		SM4040601SB		SCREW M4 L=6						4	
33		WS0621210KR		SPRING WASHER 6.2X11.4X1.2						2	
34		GAK44005000		SPRING						1	
35		GAK010220B0		LIFTER KNEE SWITCH ASM. B						1	
36	R	GAK010220A0	GAK010220B0	KNEE SWITCH ASM.				*		1	1.00
37		MTA80231T00		SWITCH INDICATION ASM				*		1	
38		MTA80230T00		SWITCH INDICATION BASE				*		2	
39		SS6151220SP		SCREW 15/64-28 L=11.5				*		4	
40	R	SS7111410SP	SS7111410TP	SCREW 11/64-40L=14				*		2	1.00
41	R	SK3514000SD	SK3514001SE	WOOD SCREW D=5.1 L=40						2	1.00

AK-44 B TYPE

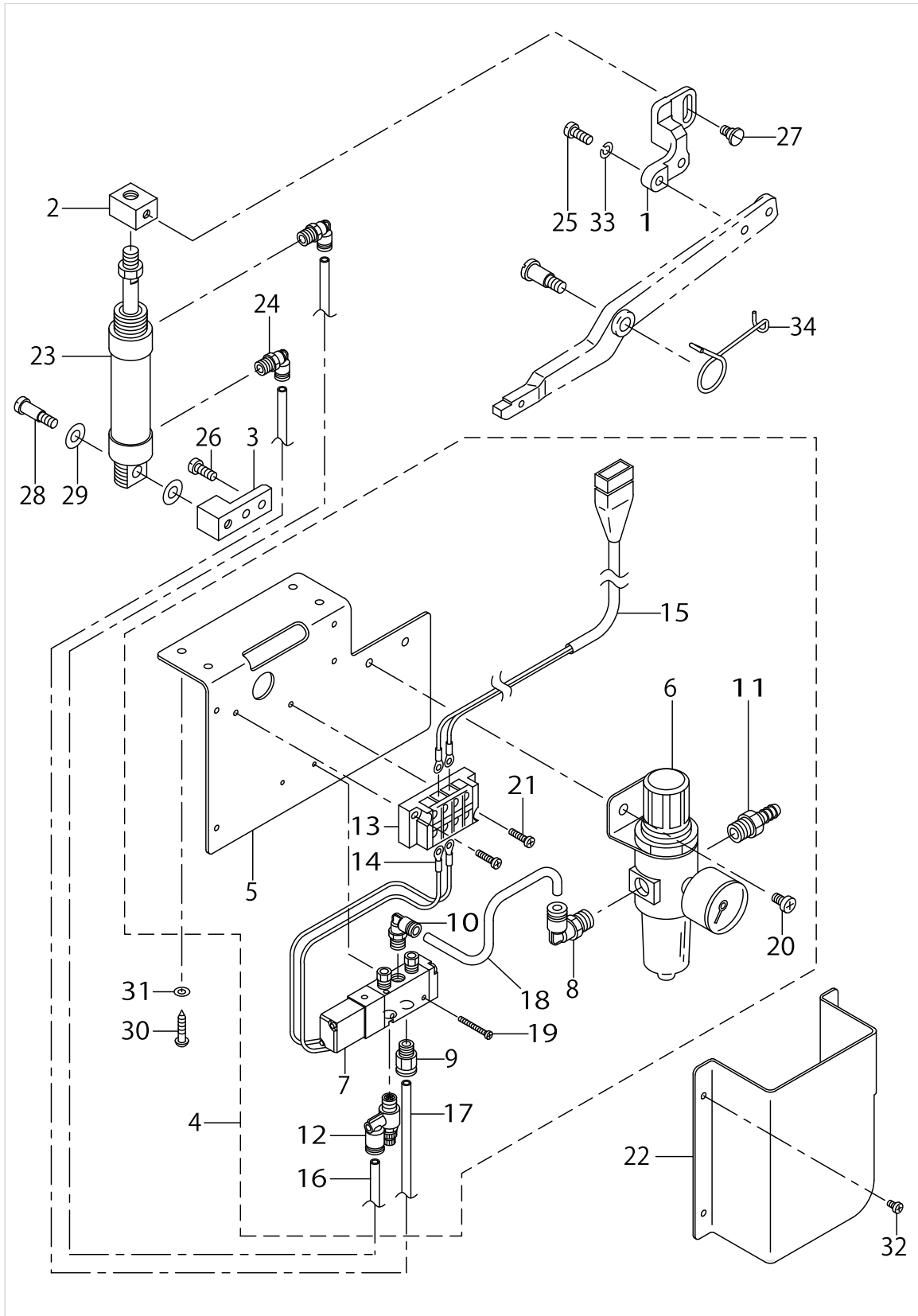

AK-44 B TYPE

No.	Supply Code	Parts No.	Replacement	Parts name	Remarks	Choice	Step	Level	Cons	Qty	Rep. QTY
1		GAK44001000		AUTOMATIC LIFTING ARM						1	
2		GAK29003000		CYLINDER BLOCK						1	
3		GAK44002000		CYLINDER BASE						1	
4	D	GAK440040A0		AIR COMPONENTS ASM.						1	
5		GAK29001000		SOLENOID VALVE MOUNTING PLATE				*		1	
6		GAK29007000		FILTER REGULATOR				*		1	
7		GAK29008000		SOLENOID VALVE				*		1	
8		GAK29009000		ELBOW				*		1	
9		GAK29015000		JOINT A				*		1	
10		GAK29010000		ELBOW B				*		1	
11		GAK29011000		NIPPLE				*		1	
12		GAK29016000		SPEED CONTROLLER				*		1	
13		GAS11419000		TERMINAL BASE				*		1	
14	D	HP001330000		CONNECTOR				*		2	
15		GAK440030A0		CORD ASM.				*		1	
16		BT0600401EB		TUBE				*		1.2	
17		BT0600401EB		TUBE				*		1.1	
18		BT0600401EB		TUBE				*		0.1	
19		SM4032501SN		SCREW M3X0.5 L=25				*		2	
20		SM4061001SB		SCREW M6 L=10				*		2	
21		SM4041601SR		SCREW M4 L=16				*		2	
22		GAK29002000		SOLENOID VALVE COVER						1	
23	R	GAK29013000	PA2502503A0	CYLINDER						1	1.00
24		GAK29010000		ELBOW B						2	
25		SS6151440SP		SCREW 15/64-28L=14						2	
26		SS6151440SP		SCREW 15/64-28L=14						2	
27		SD0790433TP		HINGE SCREW D= 7.94 H= 4.3						1	
28		SD0801601SP		HINGE SCREW D= 8 H=16						1	
29		WP0850002SP		WASHER 8.5X18X1.6						2	
30	R	SK3482500SC	SK3482501SE	WOOD SCREW D=4.8 L=25						4	1.00
31		WP0501016SC		WASHER 5X10.5X1						4	
32		SM4040601SB		SCREW M4 L=6						4	
33		WS0621210KR		SPRING WASHER 6.2X11.4X1.2						2	
34		GAK44005000		SPRING						1	

## HOW TO MAKE USE OF THIS PARTS LIST

1.As to "#01" and "#02" refer to the "Note" given at the bottom of the respective pages.

2.Codes on the "Qty" column

- Each numeral indicates the number of parts required.
- "0.1" and "2.5" indicate the length (in meters) of the respective parts.

3.Parentheses mean that the corresponding part is a subpart that constructs an assembly part.

4.Dotted lines on the Figures indicate assembly parts.

1. リストページの# 0 1、# 0 2の印は、ページ下の"注記"の説明を参照下さい。
2. 数量欄の数字は、個数を表し、0. 1、2. 5等の数値は、長さ（単位メートル）を表します。
3. 数量欄の（ ）は、組部品を構成している子部品であることを意味します。
4. イラストページの-----枠は、組構成であることを意味します。

# NUMERICAL INDEX OF PARTS

PART NO	PAGE	REF NO.	PART NO	PAGE	REF NO.
BT0600401EB	2	18	SD0801601SP	4	28
BT0600401EB	4	18	SK3482500SC	2	30
GAK010220A0	2	36	SK3482500SC	4	30
GAK010220B0	2	35	SK3514000SD	2	41
GAK020210A0	2	15	SM4032501SB	2	19
GAK29001000	2	5	SM4032501SN	4	19
GAK29001000	4	5	SM4040601SB	2	32
GAK290010A0	2	4	SM4040601SB	4	32
GAK29002000	2	22	SM4041601SR	2	21
GAK29002000	4	22	SM4041601SR	4	21
GAK29003000	2	2	SM4061001SB	2	20
GAK29003000	4	2	SM4061001SB	4	20
GAK29007000	2	6	SS6151220SP	2	39
GAK29007000	4	6	SS6151440SP	2	26
GAK29008000	2	7	SS6151440SP	4	26
GAK29008000	4	7	SS7111410SP	2	40
GAK29009000	2	8	WP0501016SC	2	31
GAK29009000	4	8	WP0501016SC	4	31
GAK29010000	2	24	WP0850002SP	2	29
GAK29010000	4	24	WP0850002SP	4	29
GAK29011000	2	11	WS0621210KR	2	33
GAK29011000	4	11	WS0621210KR	4	33
GAK29013000	2	23			
GAK29013000	4	23			
GAK29015000	2	9			
GAK29015000	4	9			
GAK29016000	2	12			
GAK29016000	4	12			
GAK44001000	2	1			
GAK44001000	4	1			
GAK44002000	2	3			
GAK44002000	4	3			
GAK440030A0	4	15			
GAK440040A0	4	4			
GAK44005000	2	34			
GAK44005000	4	34			
GAS11419000	2	13			
GAS11419000	4	13			
HP001330000	2	14			
HP001330000	4	14			
MTA80230T00	2	38			
MTA80231T00	2	37			
SD0790433TP	2	27			
SD0790433TP	4	27			
SD0801601SP	2	28			