

MODEL : TC16
List No : 1621-01

PARTS LIST

Published:05/12/2017

CONTENTS

TC16 (1).....	1
TC16 (2).....	5
HOW TO MAKE USE OF THIS PARTS LIST	7

	PARTS No.		NOTE
	FOR C11	FOR E11	
TC16A	700-02754	700-02757	WITH CONTROL BOX(FOR 220~440 V)
TC16B	700-02755	700-02758	WITH CONTROL BOX(FOR 100~240 V)
TC16C	700-02756	700-02759	SEAVO MOTOR TYPE(FOR SC921)

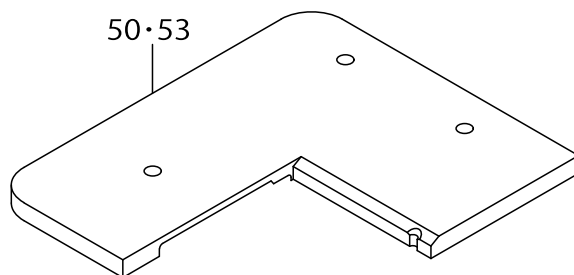
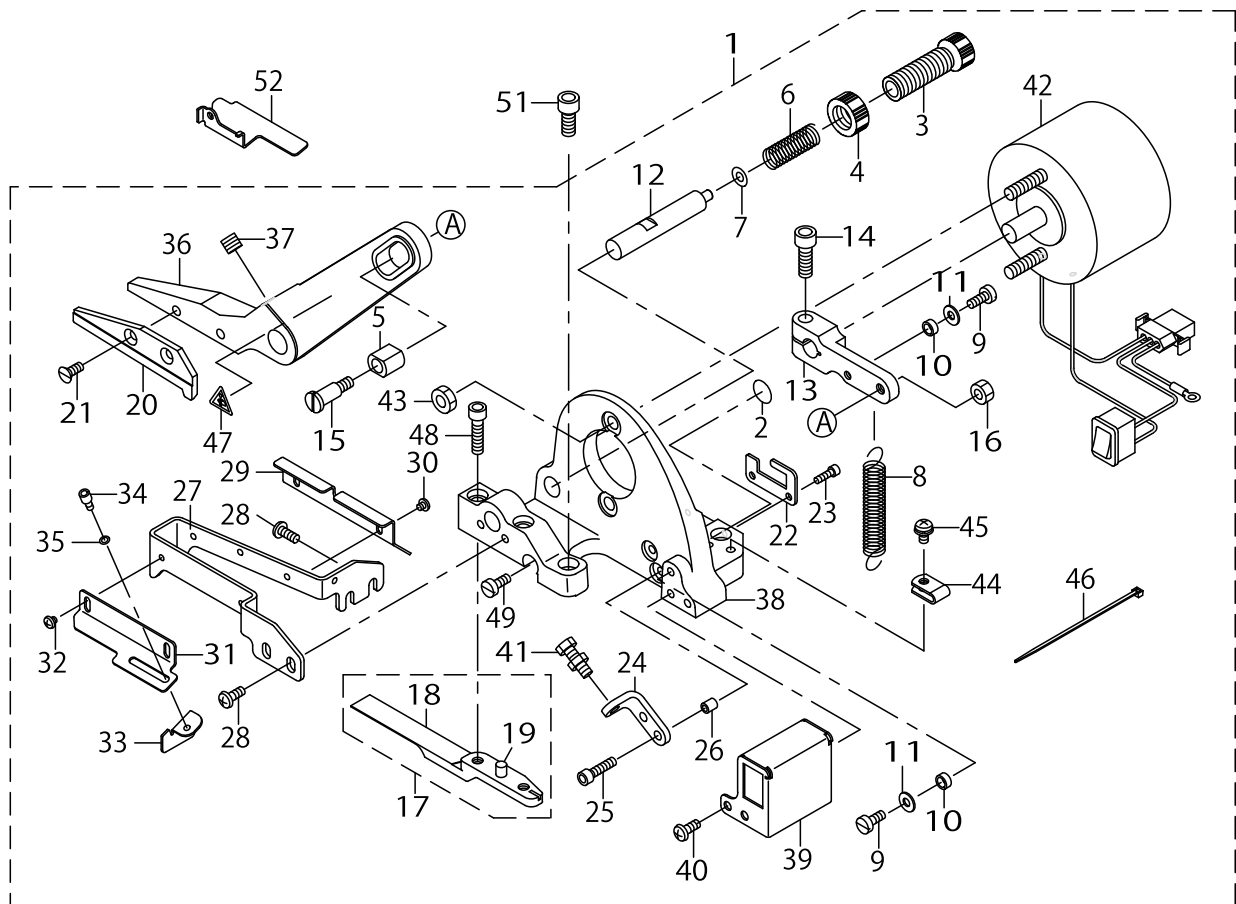

TC16 (1)

No.	Supply Code	Parts No.	Replacement	Parts name	Remarks	Choice	Step	Level	Cons	Qty	Rep. QTY
1		40043920		MG TAPE CUTTER ASM.						1	
2		22901805		GROUND MARK				*		1	
3		40011179		PRESSER SPRING REGULATOR				*		1	
4		40011180		NUT				*		1	
5	D	40019878		TC SLIDE BLOCK				*		1	
6		40019879		TC SPRING A				*		1	
7		WP0480856SP		WASHER 4.8X8.4X0.8				*		1	
8		40019880		TC SPRING B				*		1	
9		SM6041050TP		SCREW M4 L=10				*		2	
10		B1650210000		DRIVING LINK ROLLER.				*		2	
11		14030100		WASHER				*		2	
12	D	40019881		TC SHAFT				*		1	
13		40019882		TC SOLENOID LEVER				*		1	
14		SM6061802TP		SCREW M6 L=18				*		1	
15		SD0701206TP		SHOULDER SCREW D=7 H=12				*		1	
16		NM6050001SC		NUT M5				*		1	
17		40020224		TC FIXED KNIFE ASM				*		1	
18	R	40019883	40020224	TC FIXED KNIFE				*		1	1.00
19		12219705		PIN				*		1	
20		40019884		TC MOVING KNIFE				*		1	
21		SM1041000SP		SCREW M4 L=10				*		2	
22		40044022		TC CONNECTOR BKT				*		1	
23		SM6031002TP		HEXAGONAL BOLT M3 X 10				*		2	
24		40019886		TC STOPPER BKT				*		1	
25		SM6041602TP		SCREW M4X0.7 L=16				*		2	
26		B3028450000		ROLLER				*		2	
27		40069670		TC COVER A				*		1	
28		SM5041055SN		SCREW M4X10				*		4	
29		40069671		TC COVER B				*		1	
30		SM5030355SE		SCREW				*		2	
31	D	40019889		TC GUIDE A				*		1	
32		SM5030355SE		SCREW				*		2	
33		40019890		TC GUIDE B				*		1	
34		SM6030502TP		BOLT M3X5				*		1	
35		WP0320500SC		WASHER M3				*		1	
36		40019891		TC LEVER				*		1	
37		SM8060812TP		SCREW M6 L=8				*		1	
38		40019892		TC BASE				*		1	
39		40019894		TC SWITCH BOX				*		1	
40		SM5041055SN		SCREW M4X10				*		2	
41		40040451		TC STOPPER BOLT ASM.				*		1	
42		40042219		TC SOLENOID ASSY				*		1	
43		NM6060001SC		NUT M6				*		2	
44		HX001500000		CLIP				*		1	
45		SM5041055SN		SCREW M4X10				*		2	
46		EA9500B0100		CABLE BAND				*		1	

	PARTS No.		NOTE
	FOR C11	FOR E11	
TC16A	700-02754	700-02757	WITH CONTROL BOX(FOR 220~440 V)
TC16B	700-02755	700-02758	WITH CONTROL BOX(FOR 100~240 V)
TC16C	700-02756	700-02759	SEAVO MOTOR TYPE(FOR SC921)

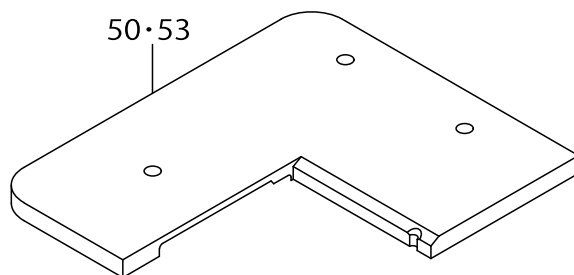
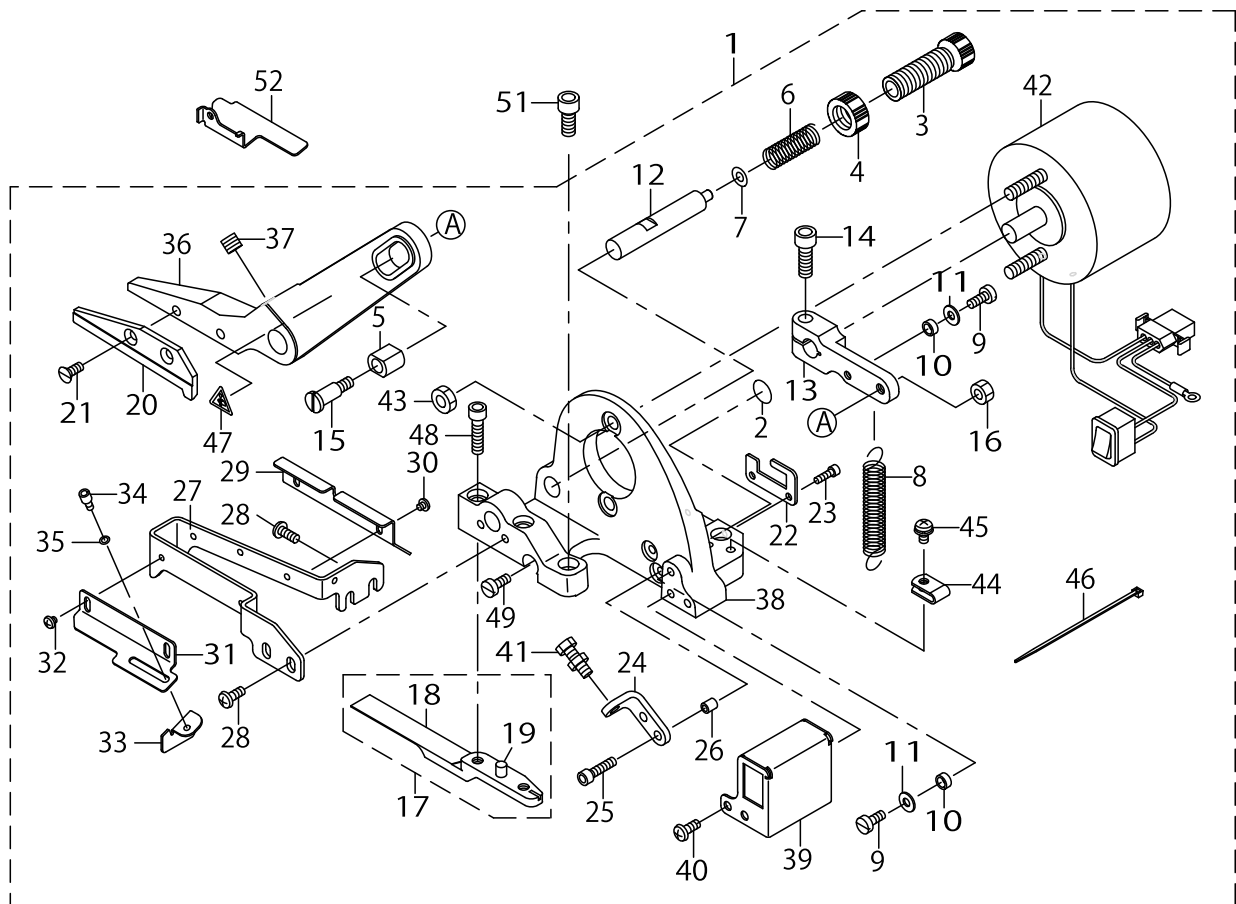

TC16 (1)

No.	Supply Code	Parts No.	Replacement	Parts name	Remarks	Choice	Step	Level	Cons	Qty	Rep. QTY
47		CM300200001		ATTENTION SEAL				*		2	
48		SM6052002TP		SCREW M5 L=20				*		2	
49		SM6041050TP		SCREW				*		1	
50		70003999		CLOTH_PLATE_LEFT_TC	FOR E11					1	
51		SM6051402TP		SCREW M5X0.8 L=14						2	
52		40019893		TC TAPE GUIDE						1	
53	R	40019896	40019895	TC CLOTH PLATE	FOR C11					1	1.00

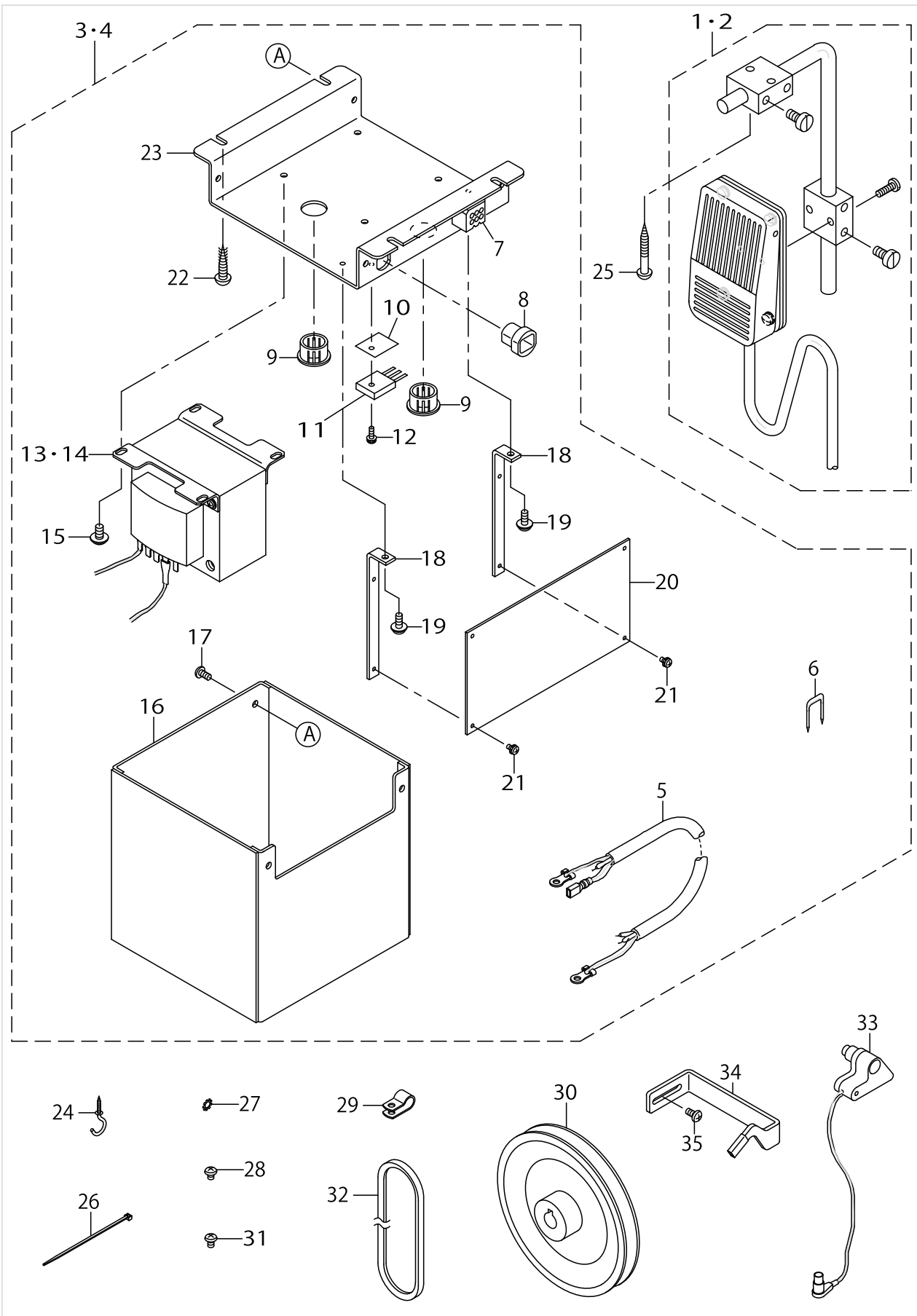

TC16 (2)

No.	Supply Code	Parts No.	Replacement	Parts name	Remarks	Choice	Step	Level	Cons	Qty	Rep. QTY
1		40042221		TC SWITCH B ASSY	FOR TC16A,TC16B					1	
2		40049440		TC SWITCH C ASSY	FOR TC16C					1	
3		40039579		T006 CONTROL BOX A ASSY	FOR TC16-A(220~440V)					1	
4		40039580		T006 CONTROL BOX B ASSY	FOR TC16-B(100~240V)					1	
5		MAT006050A0		POWER SOURCE CORD ASM.				*		1	
6		MAO11532000		CORD STAPLE				*		4	
7		40039585		CONNECTOR ASSY				*		1	
8	D	HX000210000		CORD BUSHING				*		1	
9		HX002270000		ONE TOUCH BUSH				*		2	
10		HX001970000		INSULATE PLATE				*		1	
11		40039584		TRANSISTOR ASSY				*		1	
12		SL4031081SC		SCREW M3 X 10				*		1	
13		40039583		TRANSFORMER A ASSY	FOR TC16-A(220~440V)			*		1	
14		40039588		TRANSFORMER B ASSY	FOR TC16-B(100~240V)			*		1	
15		SL4040891SC		SCREW				*		4	
16		MAT00616000		CONTROL UNIT COVER				*		1	
17		SL4040891SC		SCREW M4 L=8				*		4	
18		40039587		MCU PCB SUPPORT PLATE				*		2	
19		SL4030881SC		SCREW				*		2	
20		40039573		MCU PCB ASSY				*		1	
21		SL4030681SC		SCREW M3 L=6				*		4	
22	R	SK3482500SC	SK3482501SE	WOOD SCREW D=4.8 L=25				*		4	1.00
23		40039586		CONTROL BOX MOUNTING BASE				*		1	
24		D2113555B00		CORD SET HOOK, B						2	
25	R	SK3514000SC	SK3514001SE	WOOD SCREW D=5.1 L=40						2	1.00
26		EA9500B0100		CABLE BAND						2	
27		WT0430002KN		WASHER M4	FOR TC16C					1	
28		SM4040501SN		SCREW M4X0.7 L=5	FOR TC16C					1	
29		HX00150000C		CABLE CLIP	FOR TC16C					1	
30		MTSP0115000A		MOTOR PULLEY	FOR TC16C					1	
31		SM4040655SP		SCREW M4 L=6	FOR TC16C					1	
32		MTJVM003600		V-BELT, 36 INCH	FOR TC16C					1	
33		40026920		SYNCHRONIZERASM.	FOR TC16C					1	
34		40082313		STOPPER ASM	FOR TC16C					1	
35		SM4040855SP		SCREW	FOR TC16C					2	

HOW TO MAKE USE OF THIS PARTS LIST

- 1.As to "#01" and "#02" refer to the "Note" given at the bottom of the respective pages.
- 2.Codes on the "Qty" column
 - Each numeral indicates the number of parts required.
 - "0.1" and "2.5" indicate the length (in meters) of the respective parts.
- 3.Parentheses mean that the corresponding part is a subpart that constructs an assembly part.
- 4.Dotted lines on the Figures indicate assembly parts.

ALL PARTS NOT MENTIONED IN THIS PARTS LIST ARE SAME AS THOSE OF
MODEL MF-7500. OTHER PARTS LIST RELATED TO THIS MODEL.
*MF-7500 SERIES(NO.1596 PART NO.70002001)

NUMERICAL INDEX OF PARTS

PART NO	PAGE	REF NO.	PART NO	PAGE	REF NO.
12219705	2	19	EA9500B0100	2	46
14030100	2	11	EA9500B0100	6	26
22901805	2	2	HX000210000	6	8
40011179	2	3	HX001500000	2	44
40011180	2	4	HX00150000C	6	29
40019878	2	5	HX001970000	6	10
40019879	2	6	HX002270000	6	9
40019880	2	8	MAO11532000	6	6
40019881	2	12	MAT006050A0	6	5
40019882	2	13	MAT00616000	6	16
40019883	2	18	MTJVM003600	6	32
40019884	2	20	MTSP0115000A	6	30
40019886	2	24	NM6050001SC	2	16
40019889	2	31	NM6060001SC	2	43
40019890	2	33	SD0701206TP	2	15
40019891	2	36	SK3482500SC	6	22
40019892	2	38	SK3514000SC	6	25
40019893	4	52	SL4030681SC	6	21
40019894	2	39	SL4030881SC	6	19
40019896	4	50·53	SL4031081SC	6	12
40020224	2	17	SL4040891SC	6	17
40026920	6	33	SM1041000SP	2	21
40039573	6	20	SM4040501SN	6	28
40039579	6	3·4	SM4040655SP	6	31
40039580	6	3·4	SM4040855SP	6	35
40039583	6	13·14	SM5030355SE	2	32
40039584	6	11	SM5041055SN	2	45
40039585	6	7	SM6030502TP	2	34
40039586	6	23	SM6031002TP	2	23
40039587	6	18	SM6041050TP	2	49
40039588	6	13·14	SM6041050TP	4	49
40040451	2	41	SM6041602TP	2	25
40042219	2	42	SM6051402TP	4	51
40042221	6	1·2	SM6052002TP	4	48
40043920	2	1	SM6061802TP	2	14
40044022	2	22	SM8060812TP	2	37
40049440	6	1·2	WP0320500SC	2	35
40069670	2	27	WP0480856SP	2	7
40069671	2	29	WT0430002KN	6	27
40082313	6	34			
70003999	4	50·53			
B1650210000	2	10			
B3028450000	2	26			
CM300200001	4	47			
D2113555B00	6	24			