

**GEM0311/0611**

**GEM0311/0611-7D2-Y**

**TOP-BOTTOM FEED/COMPOUND FEED  
LOCKSTITCH FOR HEAVY DUTY MATERIAL**

**TOP-BOTTOM FEED/COMPOUND  
FEED LOCKSTITCH FOR HEAVY**

**DUTY MATERIAL WITH AUTO TRIMMER**

**上下复合/综合送料厚料平缝机  
上下复合/综合送料自动剪厚料  
平缝机**

## 使用说明书 & 零件样本

Operation Instruction & Parts Book

为了安全地使用，请您在使用之前一定阅读本使用说明书。另外，请您注意保管本使用说明书，以便随时查阅；零件更改设计时，恕不另行通知。

Read safety instructions carefully and understand them before using. Retain this Operation Instruction for future reference. Excuse for not notice in advance while the design of the sparepart has to be changed.

非常感谢您购买本公司的工业缝纫机。在使用缝纫机之前，请仔细阅读<为了您的安全使用>和使用说明书。

工业缝纫机的特性之一，是要在机针和旋梭等运动零部件附近进行操作，而这些零部件很容易引起受伤的危险，所以请在接受过培训的人员或有熟练操作技术的人员的指导下，正确地使用本缝纫机。

# 为了您的安全使用

## 1. 安全使用的标记及其意义

本使用说明书及产品所使用的标记和图案记号是为了您的安全而正确地使用本产品，防止您及他人受到危害和损害。

表示方法及含义如下：

### 说明



**危险**

如果忽视此标记而进行了错误的操作，必将导致人员死亡或重伤。



**注意**

如果忽视此标记而进行了错误的操作，有可能会引起人员受伤及造成设备损坏。

### 图案和符号



符号△表示“应注意事项”。  
三角中的图案表示必须要注意的内容。  
(如左图的符号表示“注意受伤”。)



符号○表示“禁止”。



符号●表示“必须”。  
圆圈中的图案表示必须要做的内容。  
(如左图的符号表示“必须接地”。)

Thank you very much for buying our sewing machine. Before using your new machine, please read the safety instructions below and the explanations given in the Operation Instruction.



With industrial sewing machines, it is normal to carry out work while positioned directly in front of moving parts such as the needle and thread take-up lever, and consequently there is always a danger of injury that can be caused by these parts. Follow the instructions from training personnel and instructors regarding safe and correct operation before operating the machine so that you will know how to use it correctly.

## SAFETY INSTRUCTIONS

### 1. Safety indications and their meanings

This instruction manual and the indications and symbols that are used on the machine itself are provided in order to ensure safe operation of this machine and to prevent accidents and injury to yourself or other people. The meaning of these indications and symbols are given below.

#### Indications

 <b>DANGER</b>	The instructions which follow this term indicate situations where failure to follow the instructions will almost certainly result in death or severe injury.
 <b>CAUTION</b>	The instructions which follow this term indicate situations where failure to follow the instructions could cause injury when using the machine or physical damage to equipment and surroundings.

#### Symbols



..... This symbol ( $\triangle$ ) indicates something that you should be careful of. The picture inside the triangle indicates the nature of the caution that must be taken. (For example, the symbol at left means "beware of injury".)



..... This symbol ( $\otimes$ ) indicates something that you must not do.



..... This symbol ( $\bullet$ ) indicates something that you must do. The picture inside the circle indicates the nature of the thing that must be done. (For example, the symbol at left means "you must make the ground connection".)

# 安全注意事项

## 危险



打开控制箱盖时，必须先关闭电源开关并将电源插头从插座上拔下，至少等待5分钟后，再打开控制箱盖。触摸带有高电压的区域将会造成人员伤亡。

## 注意

### 使用环境



应避免在强电气干扰源(如高频焊机)的附近使用缝纫机。  
强电气干扰源可能会影响缝纫机的正确操作。



缝纫机的最佳工作环境是相对湿度在45%-85%的范围内，干燥或潮湿的环境均会影响缝纫机的正确操作。



电源电压的波动应该在额定电压的±10%以内的环境下使用。  
电压大幅度的波动会影响缝纫机的正确操作。



使用时应避免暴露于直射的阳光下。  
直射的阳光会影响缝纫机的正确操作。



电源容量应大于缝纫机的消耗能量。电源容量不足会影响缝纫机的正确操作。



万一发生雷电暴风雨时，关闭电源开关，并将电源插头从插座上拔下。雷电可能会影响缝纫机的正确操作。



环境温度应在5°C-35°C的范围内使用。  
低温或高温会影响缝纫机的正确操作。

### 安装



请让受过培训的技术人员来安装缝纫机。



固定电缆时，不要过度弯曲电缆或用卡钉固定得过紧，会引起火灾或触电的危险。



请委托购买商店或电气专业人员进行电气配线。



如果使用带小脚轮的工作台，则应该固定小脚轮，使其不能移动。



缝纫机重约40公斤，安装工作必须由两人以上来完成。



 缝纫机头倒下或竖起时，请用双手进行操作。单手操作时因缝纫机的重量万一滑落易导致受伤。



在安装完成前，请不要连接电源，如果误按启动开关，缝纫机动作会导致受伤。



使用润滑油或黄油时，务必戴好保护眼镜和保护手套等，以防润滑油落入眼中或沾在皮肤上，这是引起发炎的原因。  
另外，润滑油或黄油不能饮用，否则会引起呕吐和腹泻。  
将油放在小孩拿不到的地方。



请在切断电源后，再拔掉电源插头。不然易成为控制箱发生故障的原因。



必须接地。接地线不牢固，是造成触电或误动作的原因。

# Notes On Safety







## DANGER













Wait at least 5 minutes after turning off the power switch and disconnecting the power cord from the wall outlet before opening the face plate of the control box. Touching areas where high voltages are present can result in severe injury.

## CAUTION

### Environmental requirements

-  Use the sewing machine in an area which is free from sources of strong electrical noise such as high-frequency welders. Sources of strong electrical noise may cause problems with correct operation.
-  Any fluctuations in the power supply voltages should be within  $\pm 10\%$  of the rated voltage for the machine. Voltage fluctuations which are greater than this may cause problems with correct operation.
-  The power supply capacity should be greater than the requirements for the sewing machine's electrical consumption. Insufficient power supply capacity may cause problems with correct operation.
-  The ambient temperature should be within the range of 5°C to 35°C during use. Temperatures which are lower or higher than this may cause problems with correct operation.
-  The relative humidity should be within the range of 45% to 85% during use, and no dew formation should occur in any devices. Excessively dry or humid environments and dew formation may cause problems with correct operation.
-  Avoid exposure to direct sunlight during use. Exposure to direct sunlight may cause problems with correct operation.
-  In the event of an electrical storm, turn off the power and disconnect the power cord from the wall outlet. Lightning may cause problems with correct operation.

### Installation

-  Machine installation should only be carried out by a qualified technician.
-  Contact your dealer or a qualified electrician for any electrical work that may need to be done.
-  The sewing machine weighs approximately 40kg. The installation should be carried out by two or more people.
-  Don't connect the power cord until installation is complete, otherwise the machine may operate if the foot switch is depressed by mistake, which could result in injury.
-  Be sure to connect the ground. If the ground connection is not secure, you run a high risk of receiving a serious electric shock, and problems with correct operation may also occur.
-  Install the safety covers to the machine head and motor.
-  Hold the machine head with both hands when tilting it back or returning it to its original position. Furthermore, after tilting back the machine head, do not push the face plate side or the pulley side from above, as this could cause the machine head to topple over, which may result in personal injury or damage to the machine.
-  All cords should be secured at least 25mm away from any moving parts. Furthermore, do not excessively bend the cords or secure them too firmly with staples, otherwise there is the danger that fire or electric shocks could occur.
-  If using a work table which has casters, the casters should be secured in such a way so that they cannot move.
-  Be sure to wear protective goggles and gloves when handling the lubricating oil and grease, so that they don't get into your eyes or onto your skin, otherwise inflammation can result. Furthermore, do not drink the oil or eat the grease under any circumstances, as they can cause vomiting and diarrhoea. Keep the oil out of the reach children.

# 安全注意事项

## 注意

### 缝纫



本缝纫机仅限于接受过安全操作培训的人员使用。



为了安全起见，在使用本缝纫机之前，请安装保护装置。如果未安装这些安全装置就使用缝纫机，会造成人身伤害及缝纫机损坏。



本缝纫机不能用于除缝纫以外的任何其他用途。



缝纫过程中不要触摸任何活动部件或将物件靠在运动部件上，因为这会导致受伤或缝纫机损坏。



发生下列情况时，请切断电源。否则误按动启动开关，缝纫机动作会导致受伤。

- 机针穿线时
- 更换机针或梭芯时
- 缝纫机不使用，或人离开缝纫机时



如果缝纫机操作中发生误动作，或者听到异常的噪声或闻到异常的气味，应立即切断电源。然后与购买商店或受过培训的技术人员联系。



如果使用带小脚轮的工作台，则应该固定小脚轮，使其不能移动。



如果缝纫机出现故障时，请与购买商店或受过培训的技术人员联系。

### 清洁



在开始清洁作业前，请切断电源。如果误踩了脚开关，缝纫机动作会导致人员受伤。



使用润滑油或黄油时，务必戴好保护眼镜和保护手套等，以防润滑油落入眼中或沾在皮肤上，这是引起发炎的原因，另外，润滑油或黄油不能饮用，否则会引起呕吐和腹泻。将油放在小孩拿不到的地方。

# Notes On Safety

## CAUTION

### Sewing



This sewing machine should only be used by operators who have received the necessary training in safe use beforehand.



If using a work table which has casters, the casters should be secured in such a way so that they cannot move.



The sewing machine should not be used for any applications other than sewing.



Attach all safety devices before using the sewing machine. If the machine is used without these devices attached, injury may result.



Be sure to wear protective goggles when using the machine.  
If goggles are not worn, there is the danger that if a needle breaks, parts of the broken needle may enter your eyes and injury may result.



Do not touch any of the moving parts or press any objects against the machine while sewing as this may result in personal injury or damage to the machine.



Turn off the power switch at the following times, otherwise the machine may operate if the foot switch is depressed by mistake, which could result in injury.

- When threading the needle
- When replacing the needle and bobbin
- When not using the machine and when leaving the machine unattended



If an error occurs in machine operation, or if abnormal noises or smells are noticed, immediately turn off the power switch. Then contact your nearest dealer or a qualified technician.



If the machine develops a problem, contact your nearest dealer or a qualified technician.

### Cleaning



Turn off the power switch before carrying out cleaning, otherwise the machine may operate if the foot switch is depressed by mistake, which could result in injury.



Be sure to wear protective goggles and gloves when handling the lubricating oil and grease, so that they do not get into your eyes or onto your skin, otherwise inflammation can result. Furthermore, do not drink the oil or eat the grease under any circumstances, as they can cause vomiting and diarrhoea. Keep the oil out of the reach of children.

# 目录 CONTENTS

---

1.机器简介 Profile of the machine .....	1
2.规格 Specifications .....	1
3.机头的安装 Install the machine .....	1
4.皮带的安装 Installation .....	2
5.膝控装置安装 Install the knee-control device .....	2
6.皮带罩的安装 Install the belt cover .....	2
7.绕底线及调整 Winding and adjusting lower thread .....	3
8.润滑 Lubricating .....	4
9.旋梭润滑的调整 Rotary hook lubrication adjustment .....	4
10.油泵的调整 Pump adjustment .....	5
11.安装机针 Replace needles .....	5
12.穿面线 Routing upper thread .....	5
13.线张力调整 Adjusting the thread tension .....	6
14.压脚压力的调整 Presser foot pressure .....	6
15.调整送布牙 Adjusting the feed dog .....	7
16.内外压脚的调整 Adjusting the auxiliary and upper feed presser foot .....	7
17.送布牙同步关系的调整 Adjusting the synchronous relationship of the feed dog .....	9
18.调节针杆停针位置 Adjusting the needle stop posting(自动离线型) .....	10
19.接线 .....	10
20.剪线机构的调整 Adjusting for thread trimmer .....	11
21.定期清洁机器 Regular cleaning machine .....	13
22.故障原因及对策 Causes of troubles and troublesshooting .....	14
23.台板加工图 Schematic diagram of the machine table .....	16
24.零件样本 PARTS CONTENTS .....	17-38
索引 INDEX .....	I -III



## 1. 机器简介 Profile of the machine

本系列平缝机（自动剪线）单直针，采用连杆式送料，挑线杆挑线，旋梭勾线，形成301线迹。机头加长设计，令操作回转空间更宽敞。超长针杆行程，大互动量交替压脚，使缝厚能力更显出色。

本机采用油泵自动润滑,运转轻滑、噪音低、振动小,特别适合手箱包、汽车座垫、帐篷、沙发等皮革、帆布、厚重装饰布、织带类物品的缝制。



Thick material up and down feeding (auto trimming) a single straight needle sewing machine system, using the link type feed, thread take-up pick-line, Rotating hook line, form 301 stitch. Extended nose design, make operation more spacious space rotation. Long needle bar stroke, a large amount of interaction alternating presser foot, so that Seam thickness capacity is even more remarkable.

This machine adopts oil pump auto lubrication, smooth running light, low noise, vibration, especially for hand luggage, car seat, tents, sofas and other leather, Canvas, heavy fabrics, sewing items like ribbon.

## 2. 规格 Specifications

型号 Type	0311/0611		0311/0611-7D2-Y	
用途 Tailor	中厚料~厚料 Thick			
最高转速 Sewing speed	2200rpm			
最大针距 Stitch length	9mm			
针杆行程 Needle	38mm			
挑线杆行程 Thread take-up	73mm			
压脚交互量 Presser foot interactive quantity	2. 0-5. 5mm			
外压脚操作系统 The presser foot operating system	标盘 Standard plate			
机针 Needle	DPx17 23#			
旋梭 Hook	全自动润滑大旋梭	全自动润滑大旋梭(剪线)		
润滑系统 Lubrication system	自动供油			
剪线装置 Trimming device	无 ×	有 ○		
倒缝装置 Reverse stitching device	无 ×	有 ○		
压脚提升高度 Press foot hoisting height control	手提 Hand control	7mm		
	膝提 Knee	16mm		
配套电机功率 (W)	≥550mm		≥550mm	

## 3. 机头的安装 Install the machine

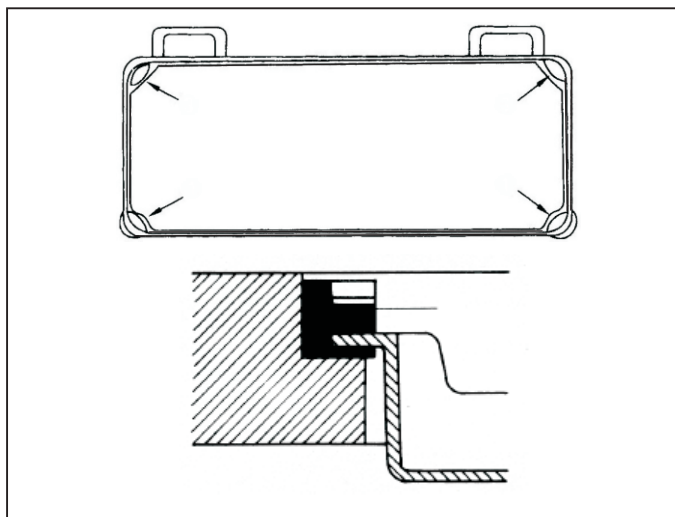

- 1)将机头支座固定在工作台凹槽四角。
- 2)将油盘四角搁在机头支架的中间。
- 3)将机头连接钩放入底板孔内，与台板的机头铰链相嵌合，再将机头放到四只角的机头支座上。



- 1.Put the rubber cushion on the four corner of the tale socket.
- 2.Hold the oil reservoir in the middle of the rubber cushion.
- 3.Put the head connecting hook socket into table, then connect the head connecting hook socket and the head connecting hook which should be on the head, and the machine head will be put on the oil reservoir.

#### 4. 皮带的安装 Installation

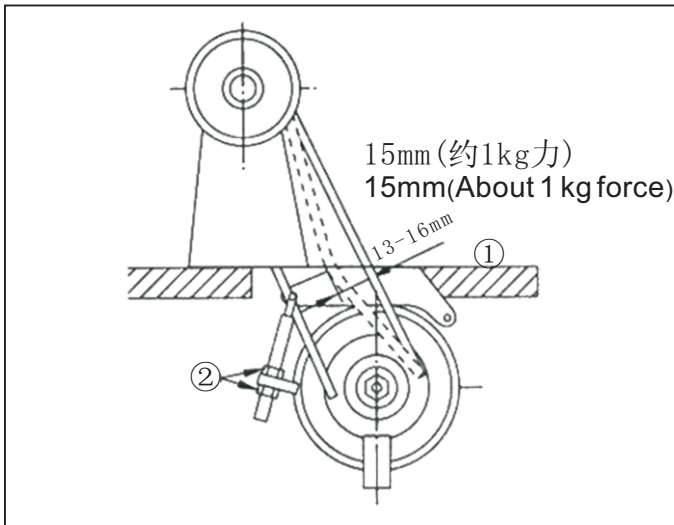

1. 放倒机头, 在电机下皮带轮上安装三角皮带①。
2. 用手指以1kg力压三角皮带①, 调整螺母②, 使皮带弯曲程度为13-16mm。

EN

1. Tilt back the machine head, and then place the belt ① onto the motor pulley and the machine pulley.
2. Turn the nut ② to adjust so that there is 13-16mm of deflection in the belt ① when it is pressed with a finger.

#### 5. 膝控装置安装 Install the knee-control device

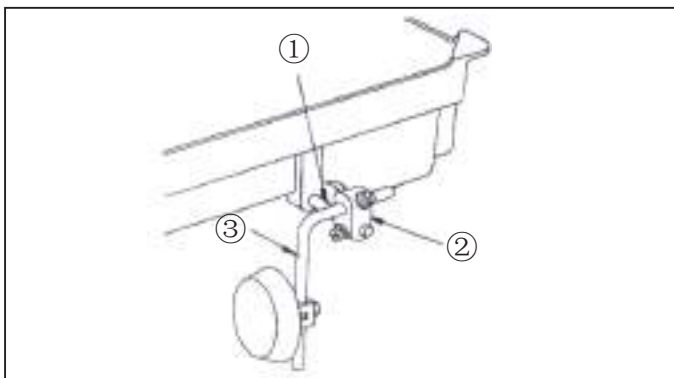

1. 尽量拉出膝控铰链轴①, 进行适当安装。
2. 在轴上装上膝控碰块接头②。
3. 在膝控碰块接头上装膝控碰块弯轴组件③。

EN

1. Pull the device ① and adjust it.
2. Install the joint ②.
3. Install device ③.

#### 6. 皮带罩的安装 Install the belt cover

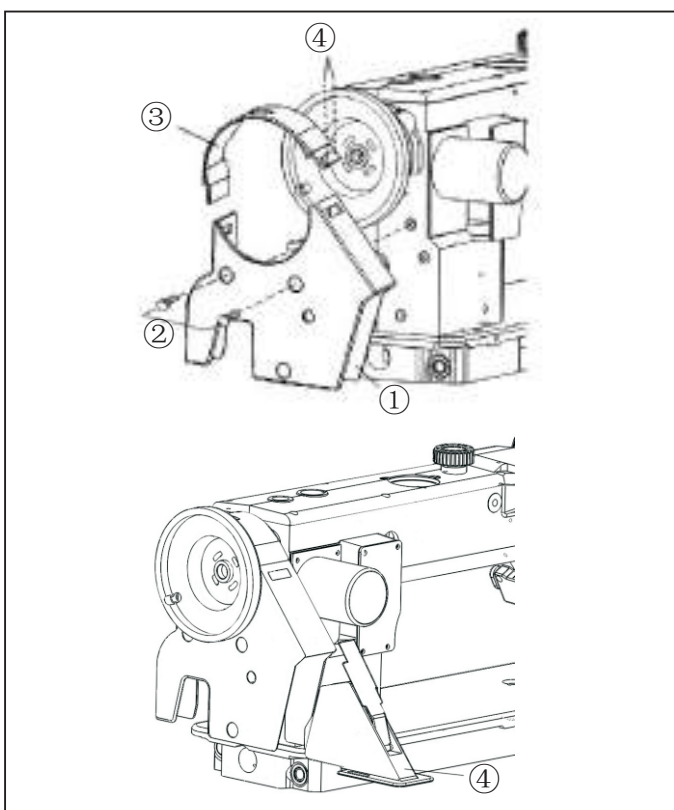

1. 利用三个固定螺丝, 把皮带护罩①固定在缝纫机机体上。  
此时, 若把缝纫机稍微往后倾斜, 就会易于组装皮带护罩①。

组装完皮带护罩①后, 把皮带护罩③的前部插在皮带护罩①的小孔里, 利用固定螺丝④把其后部固定好。

2. 把皮带护罩④伏贴在工作台上。

此时, 请注意, 不让皮带在皮带护罩④内部干涉。

EN

1. Fix the belt cover ① to the machine's body using 3 fixing screws ②.

You can assemble it more easily if you slightly incline the machine.

When the assembly of the belt cover is finished, insert the front side of the belt cover ③ into the groove of belt cover ① and fix the back side with the fixing screw ④.

2. Attach the belt cover ④ to the table.

Please make sure that the belt do not intervene with the inside of the belt cover ④.

## 7. 绕底线及调整 Winding and adjusting lower thread

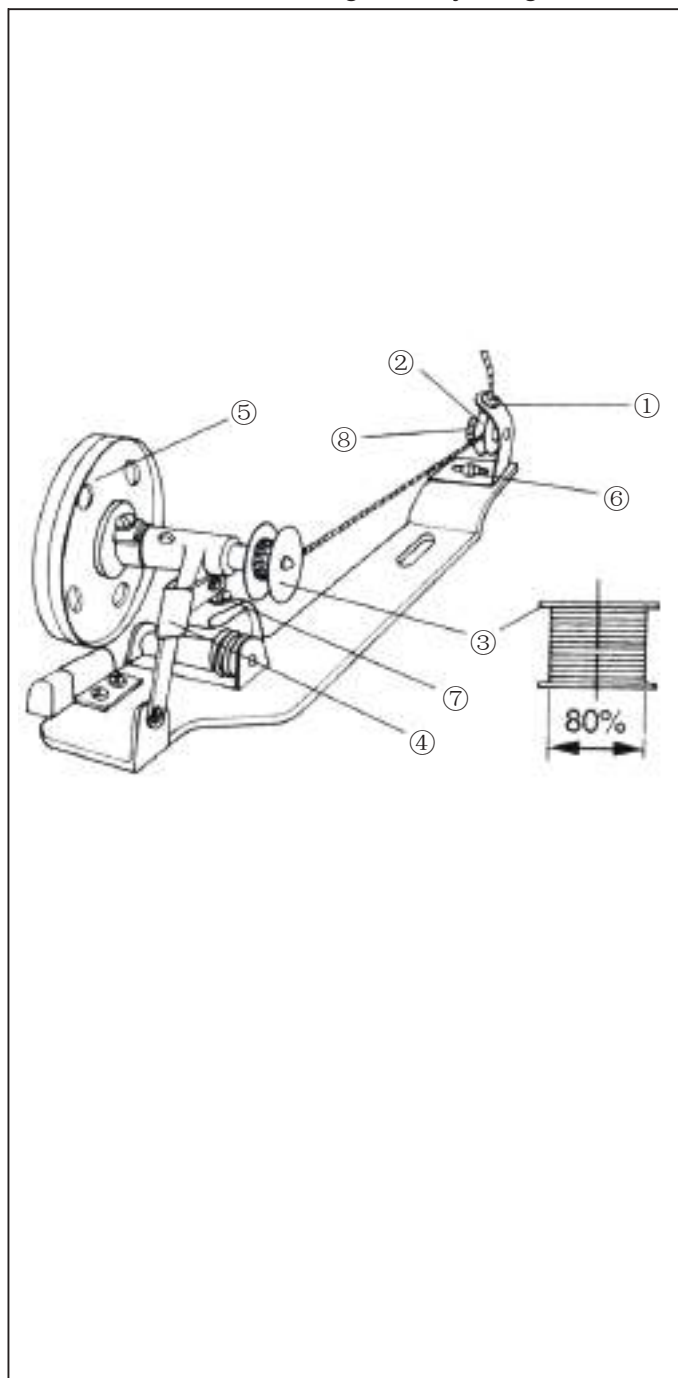

### A. 绕底线

- (1) 把线从孔①中穿出，从夹线器②的后面绕到前面。
- (2) 把线拉到梭芯③，从底顺时针绕5-6圈。
- (3) 推杠杆④，让滑轮⑤触到V皮带后，启动机械。
- (4) 梭芯绕完底线后，滑轮⑤自动从V-皮带移开。
- (5) 梭芯绕底线量以80%左右为宜。

### B. 绕底线调整

- (1) 底线绕得不均匀时，松开螺丝⑥后左右移动进行调整，然后重新拧紧螺丝⑥。
- (2) 顺时针转动调整螺丝⑦时，底线绕线量会增加，相反则减少。
- (3) 顺时针转动螺母⑧时，梭芯绕的底线张力会增加，相反则减小。

## EN

### A. Winding lower thread

- (1) Pass the thread thru the hole ① from the rear to the frontal side of the tension adjusting dish②
- (2) Bring the thread to the bobbin③ and wind it clockwise 5 to 6 times from the bottom.
- (3) Push the lever④ so that the pulley⑤ touches the V-belt and run the machine.
- (4) The pulley⑤ automatically is separated from the V-belt when the lower thread is winded in the bobbin.
- (5) The adequate amount of the pulled-out lower thread is about 80%.

### B. Adjustment of winding lower thread

- (1) In case that the lower thread is winded irregular, loosen the bolt ⑥ and adjust by moving it sideways, and tight it again.
- (2) The amount of winded lower thread becomes larger when you turn adjusting screw⑦ clockwise, and it becomes smaller in case of turning it counterclockwise.
- (3) The tension of lower thread that winded in the bobbin can be adjusted by turning the nut⑧: it increases with clockwise turning and it decreases when you turn counterclockwise.

## 8. 润滑 Lubricating

 <p><b>注意</b> CAUTION</p>	<p>加油结束之前，不能接触电源开关，否则误踩踏板启动，可能会受伤事故。加润滑油时，请使用保护身体的眼镜。手套防止与眼或皮肤接触，同时应放在小孩碰不到的地方。</p> <p>首次使用机械时，或长时间不使用时，必须加油。</p> <p>Plug in only after oil supply is finished. If the operator mistakenly steps on the pedal with the plug in, the machine will start automatically and can cause severe injuries.</p> <p>When handling lubricants, wear protective glasses or gloves to avoid contact with your eyes or skin. Inflammation may be caused otherwise. Never drink lubricants since they can cause vomiting or diarrhea. Keep out of the reach of children.</p> <p>Operate the machine only after adding oil when the machine is being used for the first time or has been left unused for a long time.</p>
--	--

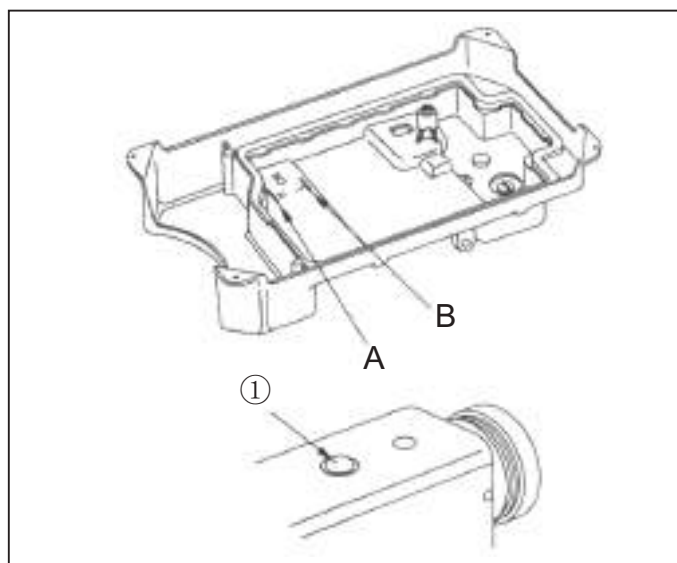

将油注入油盘A位置。  
在操作过程中，需经常检查油位高度，如油位低于B位置时须加油至A位置。

注意：操作机器时，可以通过油窗①检查油润滑情况。

**EN**

Fill oil pan with new special oil up to A .  
In the operating process, need to check the level of the oil level. After filling the oil pan, the oil surface should lie A lines.

Note: Operating machine, Can through the oil window ① check the oil lubrication condition.

 <p><b>注意</b> CAUTION</p>	<p>在以下机器的调整时，请关闭电源开关。误踩踏板机械启动时，可能会发生身体损伤事故。</p> <p>使用离合式马达时，关闭电源后，由于惯性，马达会暂时旋转。马达完全停止后，进行操作。</p> <p>Always turn off the power when mounting a needle. If the operator mistakenly steps on the pedal while the power is on, the machine will start automatically and can result in physical injuries.</p> <p>When using clutch motor, be aware that the motor will continue to rotate for a while even after the power is switched off due to inertia. Start to work on the sewing machine only after the motor has come to a complete stop.</p>
--	---

## 9. 旋梭润滑的调整 Rotary hook lubrication adjustment

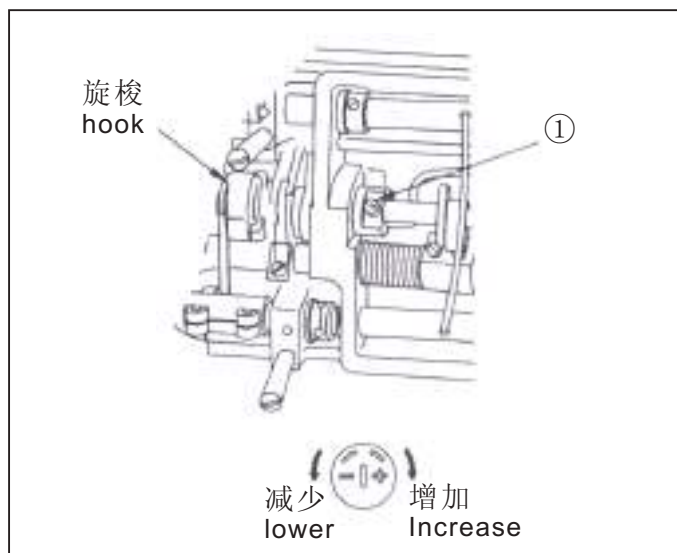

顺时针 (+) 转动油量调整螺丝①，出油量会增加，相反逆时针 (-) 转动油量调整螺丝①时，出油量会减少。

注：调整该螺钉后，机器应至少运转30秒钟，然后检查旋梭出油量。

**EN**

When you turn clockwise (+) the lubrication adjustment screw ① inserted in the front bushing of the lower shaft, the amount of oil will increase while turning to counterclockwise (-) will decrease the amount.

Note: Adjust the screws, the machine should be running at least 30 seconds, then check whether the oil into the hook.

## 10. 油泵的调整 Pump adjustment

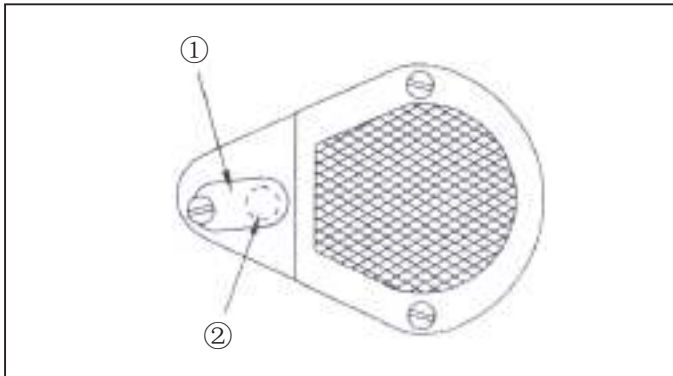

调整方法如下:

油量调节板①应充分盖住通油孔②, 如果减少供油量, 就将通油孔②适当的打开.

EN

Adjustment:

Oil leakage adjust device ① should cover the oil hole ②, if reduce the oil suppling, open oil hole ② pnerperly.

## 11. 安装机针 Replace needles



注意

CAUTION

为了防止缝纫机的意外启动, 请关掉电源之后进行操作

Turn OFF the power before starting the work so as to prevent accidents caused by abrupt start of the sewing machine.

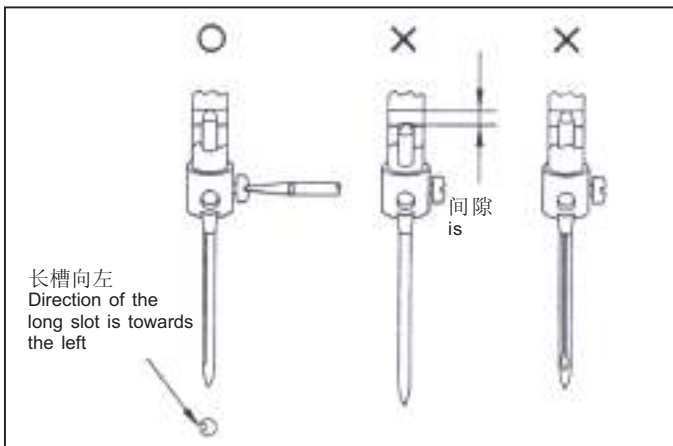

插入机针至底部, 拧紧螺钉, 保持长槽方向向左.

注意: 用涤纶线倒缝时若发生断线, 前机针的长槽向前侧转, 有可能会避免该情况发生. 一般避免将长槽朝向后侧.

EN

Needle should reach the bottom of needle bar, and then tighten the screw. Direction of the long slot is towards the left.

## 12. 穿面线 Routing upper thread

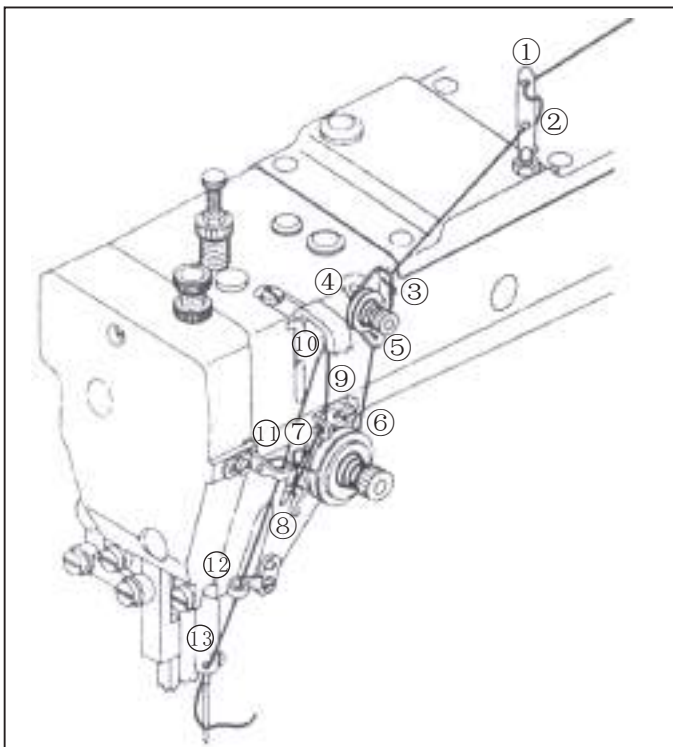

将挑线杆转到最高位置, 然后如图所示穿线.

EN

Into the thread take-up position, then as shown threading.

### 13. 线张力调整 Adjusting the thread tension

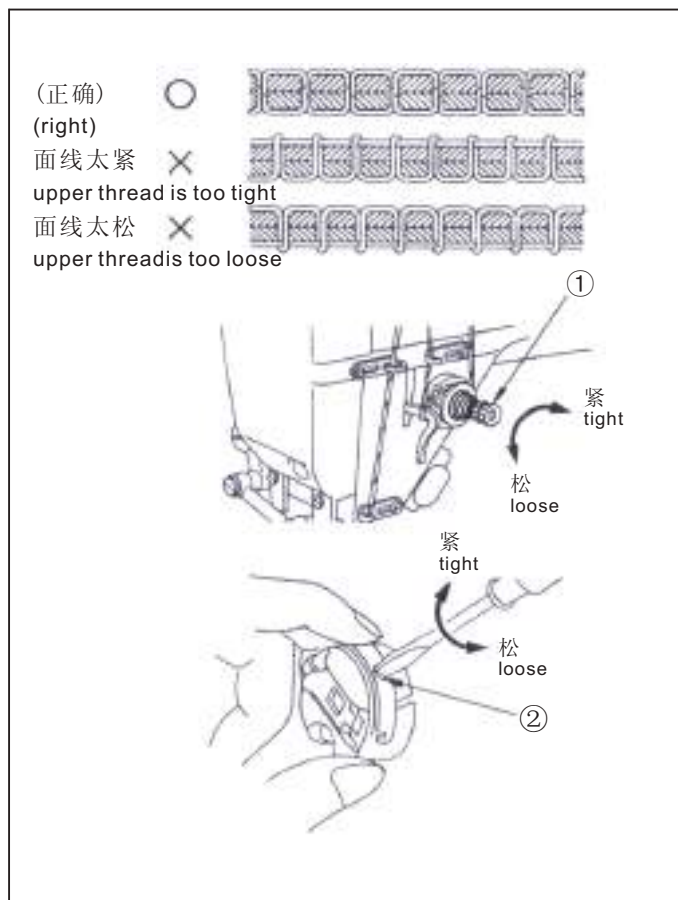

#### 1. 线调整装置

如图所示，顺时针转动压线螺母①，面线张力会变强，相反则会变弱。根据布料、缝线、线距等缝纫条件，线的张力会有所不同，因此需要按照不同情况，进行调整。

#### 2. 底线张力调整

如图所示，在线调整螺钉②上利用起子，顺时针转动，底线张力会变强，相反则会变弱。

EN

#### 1. Thread control assembly

Like in Figure, turning the tension adjustment nut ① of the thread tension control assembly clockwise makes the upper thread tension stronger and counterclockwise makes it weaker. The result of the needlework depends on the sewing conditions such as the sewing material, used thread and stitch length. So please adjust as desired.

#### B. Adjusting the thread take up tension

As in Figure 27, insert the driver into the groove ② of the thread tension control assembly. Turn clockwise to make the spring tension stronger and counter clockwise to make it weaker.

### 14. 压脚压力的调整 Presser foot pressure

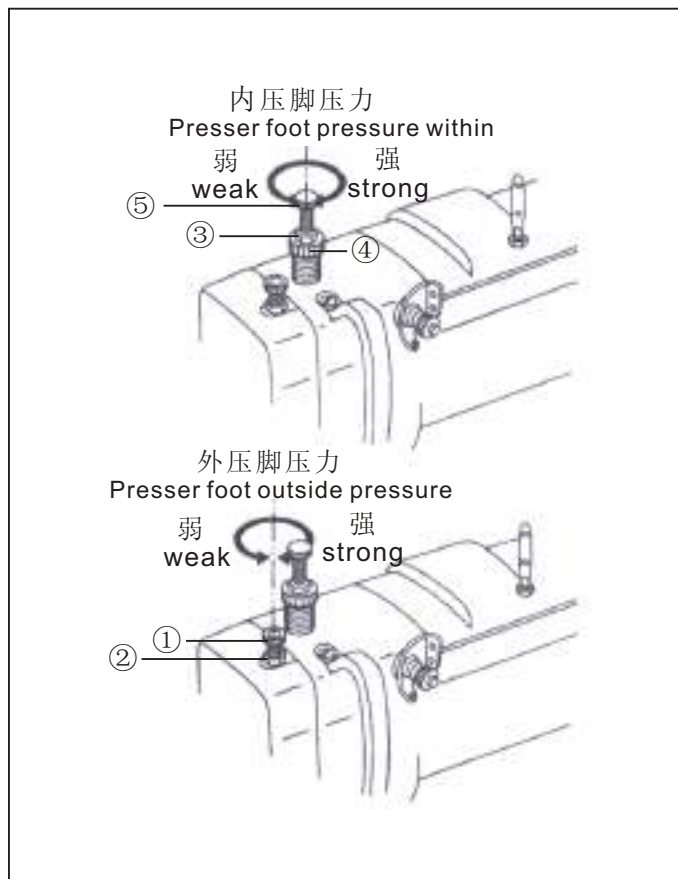

要调整内压力时，顺时针转动压力调整螺丝①，压力会变强，相反则会变弱。调整后，必须完全拧紧固定螺丝②。

外压脚也同样，顺时针转动压力调整螺丝③，压力会变强，相反则会变弱。调整后，必须完全拧紧固定螺丝④。此外，左右转动辅助压力调节螺丝，进行微细调节。

EN

The pressure of the upper feed presser foot becomes stronger when you turn the pressure adjustment screw ① clockwise, and becomes weaker in case of turning it counterclockwise.

After the adjustment, be sure to tight the fixing nut ②.

The auxiliary presser foot is same to the upper feed presser foot: the pressure increases when you turn the pressure adjustment screw ③ clockwise, and becomes weaker in case of turning it counterclockwise.

After the adjustment, be sure to tight the fixing nut ④.

In case of fine adjustment, use the auxiliary pressure adjustment screw ⑤.

### 15. 调整送布牙 Adjusting the feed dog

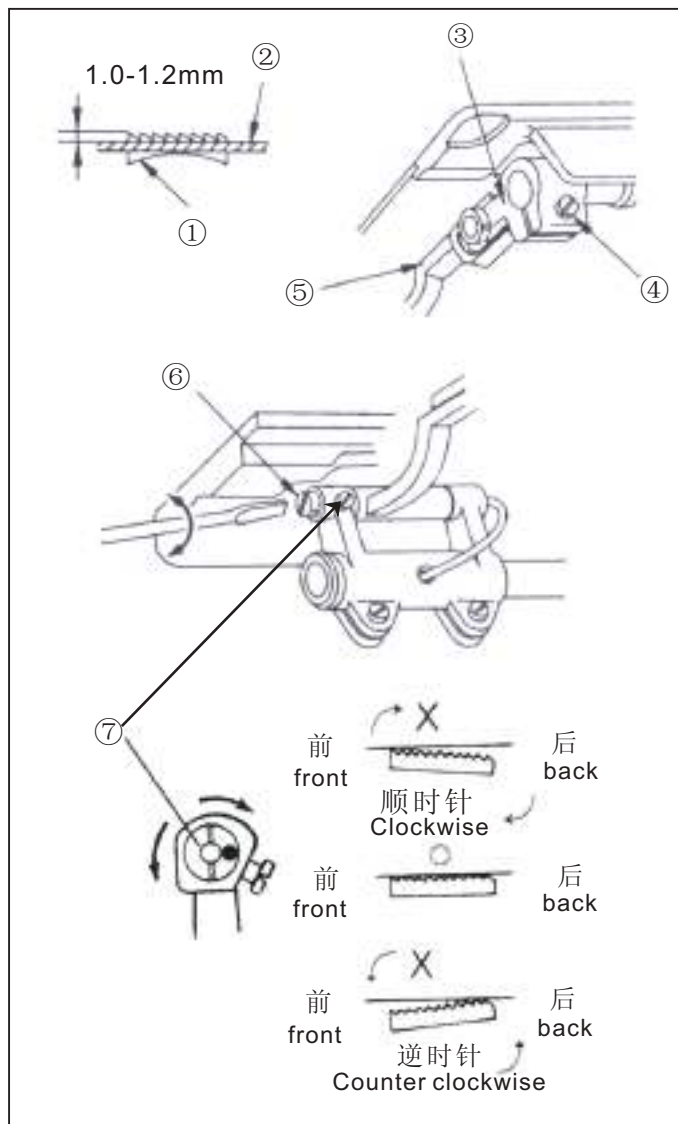

1. 送布牙高度
  - (1)送布牙①应高于针板②平面1.0-1.2mm为宜。
  - 1)放松抬牙曲柄(前)③上的螺钉④,然后将牙架⑤上下移动。
  - 2)调整结束后,旋紧螺钉④。
2. 调整送布牙倾角
  - (1)旋松螺钉⑦。
  - (2)用螺钉刀左右旋转牙架曲柄偏心轴⑥进行整.若顺时针转动,牙架曲柄偏心轴⑥、牙齿前高后低,若按相反方向逆时针转动牙架曲柄偏心轴⑥、牙齿前低后高。
  - (3)调整结束,旋紧螺钉⑦。

EN

1. Feed dog height.
  - (1)feed dog ① should higher than ② 1.0mm.
  - (2)adjust the feed dog height.
  - 1)loose the screw ④ in crank ③ and lower down ⑤ .
  - 2)after adjust,tight the screw ④.
2. Adjust the feed dog angle.
  - (1)loose screw ⑦.
  - (2)adjust ⑥.
  - (3)finish and tightening ⑦.

### 16. 内外压脚的调整 Adjusting the auxiliary and upper feed presser foot

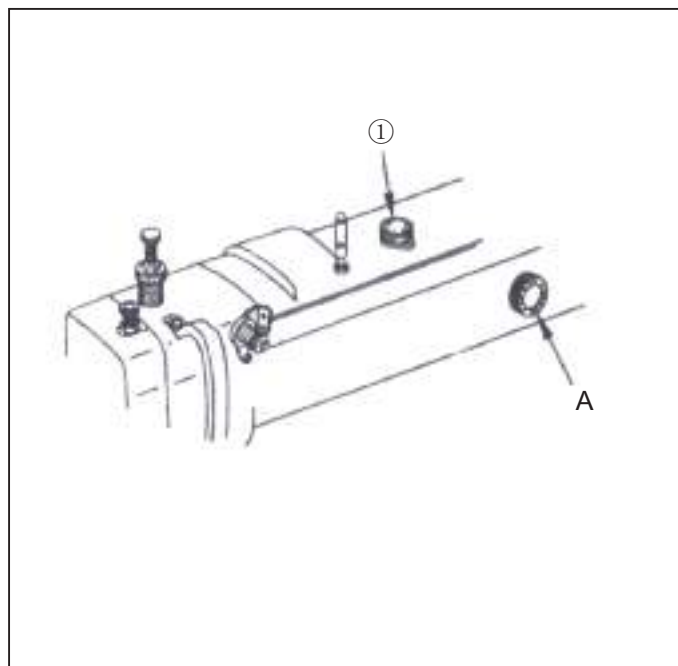

1. 交互运动的调整
    - (1)内外压脚的交互量调整范围为2mm-5.5mm。
    - (2)内外压脚的交互运动量可通过机壳上的提升压脚标盘A来调节。
    - (3)上盖板的标盘①是限制提升压脚标盘A的。
- 注: 由小到大进行调整时,先调整标盘①,再调整标盘A;相反,由大到小进行调整时,先调整标盘A,再调整标盘①。

EN

1. Interactive motion adjustment
    - (1)The vertical running range of the auxiliary presser foot and the upper feed presser foot is from 2 to 5.5 mm.
    - (2)The vertical running amounts of the auxiliary presser foot and the upper feed presser foot are easily adjustable from the climb device dial attached to the front side of the machine.
    - (3)The dial ① attached to the upper cover is a dial which controls the running amount dial A.
- Caution:When you adjust the number from lower one to a higher, you should adjust the dial ① reverse case, the adjustment of the dial A should be done first.

## 16. 内外压脚的调整 Adjusting the auxiliary and upper feed presser foot

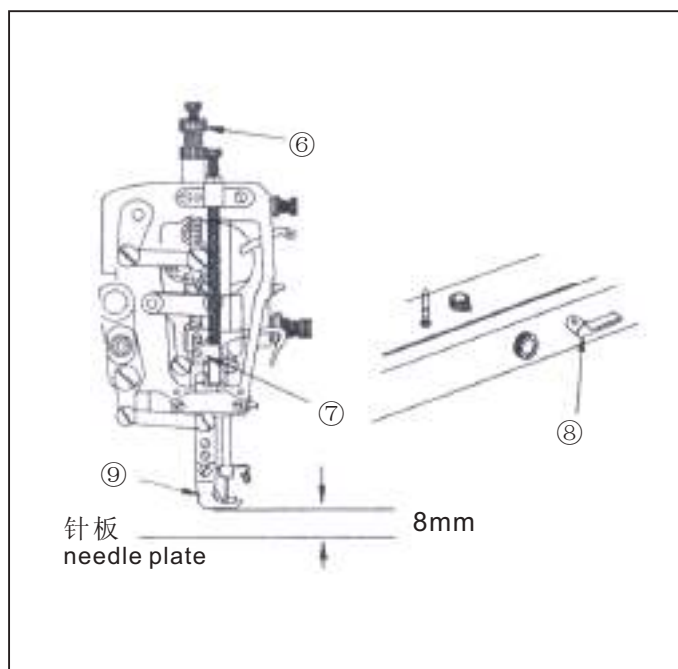
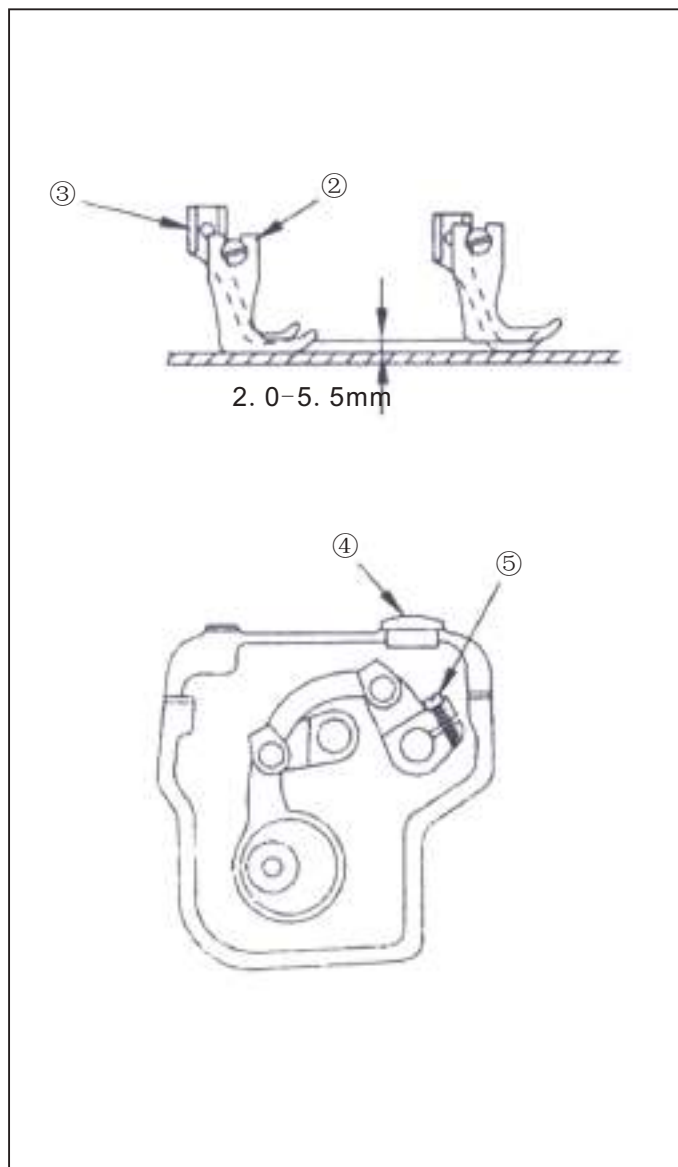

### 2. 改变内外压脚的交互运动的平衡

(1) 增加外压脚②的提升量并减少内压脚③提升量。

1) 取下上盖板上的橡皮塞④。

2) 旋转主动轮直到内压脚③从针板上抬起。

3) 旋松螺钉⑤。

4) 将内压脚向下调到接触针板，再旋紧螺钉⑤。

5) 这样，内压脚的提升量就减少一定的值，而外压脚的提升量则增加同样的数值。

(2) 与上面相反的情况，减少外压脚的提升量，增大内压脚提升量的调整如下：

1) 首先，旋转主动轮直到外压脚抬高离针板。

2) 旋松螺钉⑤。

3) 调好后，旋紧螺钉⑤。这样将减少外压脚的提升量。

EN

### 2. To change the balance the interactive movement of inner and outer presser foot

(1) Increase the height of outer presser foot② and decrease the height of inner presser foot③.

1) Remove rubber stopper④ from the upper back cover.

2) Rotate the hand wheel until inner presser foot③ lift from the needle plate.

3) Loosen the screw⑤.

4) Lower the inner presser foot to the needle plate and tighten screw⑤.

5) In this way, the height of the inner presser foot decreased by a certain value and the outer increased by the same value.

(2) Contrary to the above, to decrease the height of the outer presser foot and increase the height of the inner presser foot, the adjustment is as follows:

1) Firstly, rotate the hand wheel until the outer presser foot lifted from the needle plate.

2) Loosen screw⑤.

3) After adjustment, tighten screw⑤, thus decreasing the height of the outer presser foot.

### 3. 外压脚的调整方法

松开调压螺钉⑥和压杆导架螺钉⑦。

提升压脚扳手⑧时，上下调整压杆导架螺钉⑦。

让外压脚⑨提升到离针板上8毫米的位置。

调整完后，完全拧紧压杆导架螺钉⑦。适当调好调压螺钉⑥。

EN

### 3. Adjusting the auxiliary presser foot

Loosen the presser bar pressure adjustment screw⑥ and the bracket fixing screw⑦.

Adjust vertically the bracket fixing screw⑦ so that the auxiliary presser foot⑨ goes up by 8mm from the upper side of the needle plate when the presser bar lifter⑧ is up.

When the adjustment is finished, fix tightly the bracket fixing screw⑦ and adjust adequately the pressure adjustment screw⑥.



## 16. 内外压脚的调整 Adjusting the auxiliary and upper feed presser foot

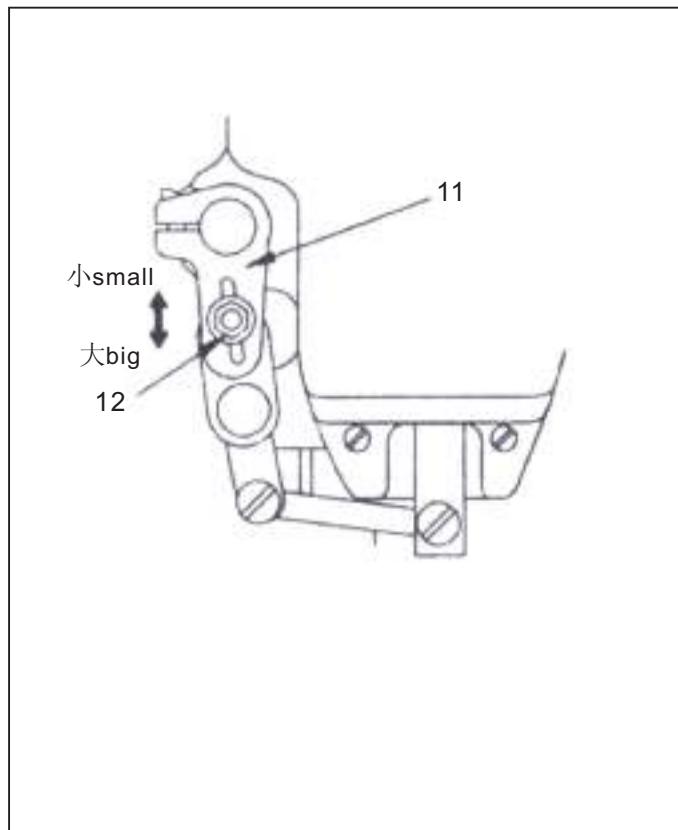

### 4. 外压脚运动量的调整

外压脚和送布牙运动量以1:1为标准，根据缝制条件，能调整外压脚的运动量。

松开位于压脚摆动曲柄(左)11上的螺母12，往上移动提升压脚变动曲柄轴，运动量会变小，相反就会变大。

EN

### 4. Adjusting feeding amount of auxiliary presser foot

The normal proportion of feeding amount between the feed dog and the auxiliary presser foot is 1:1. You can adjust the feeding amount of the auxiliary presser foot in accordance with the conditions of materials in use. loosen the nut 12 and move upward the presser foot vertical move control shaft, and the feeding amount becomes smaller. If you move it downward, the amount increases. Be sure to tight the nut 12 when the adjustment is finished.

## 17. 送布牙同步关系的调整 Adjusting the synchronous relationship of the feed dog

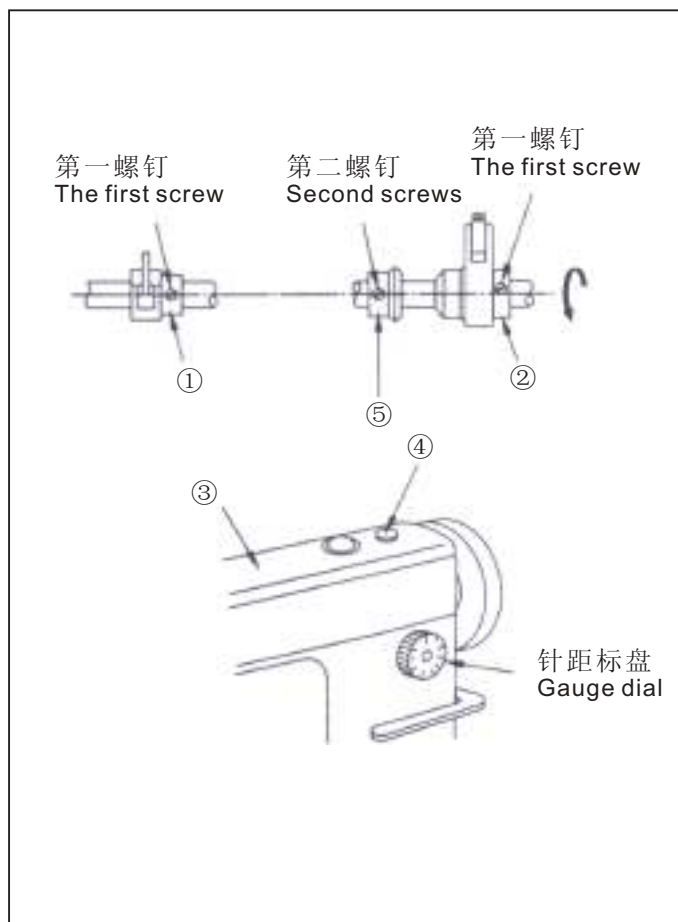

### 1. 转动手轮，使针杆位于最高位置；

2. 打开上盖，如图所示位置：送布凸轮“左”①的第一颗螺钉和送布凸轮“右”②上的第一颗螺钉与上轴中心线位于同一平面上。

注：送布凸轮②的位置调节，可以取下上盖上的橡皮塞④进行，但是单齿轮⑤不易看到，调节时应小心保护。

EN

1. turn the pulley with hands to fix the needle bar to the highest point.

2. The standard position will be when the center of the No. 1 fixing bolt of the presser foot vertical move cam ① is aligned with the center line of the upper shaft, the bottom of the No. 1 fixing bolt of the feed cam ② is aligned with the center line of the upper shaft.

Caution: When adjusting the feed lifting cam ②, users can remove the rubber plug ④ of the upper cover. During adjusting, users should be cautious because it is hard to have a vision of the single gear ⑤.

## 18. 调节针杆停针位置 Adjusting the needle stop posting (自动剪线型)

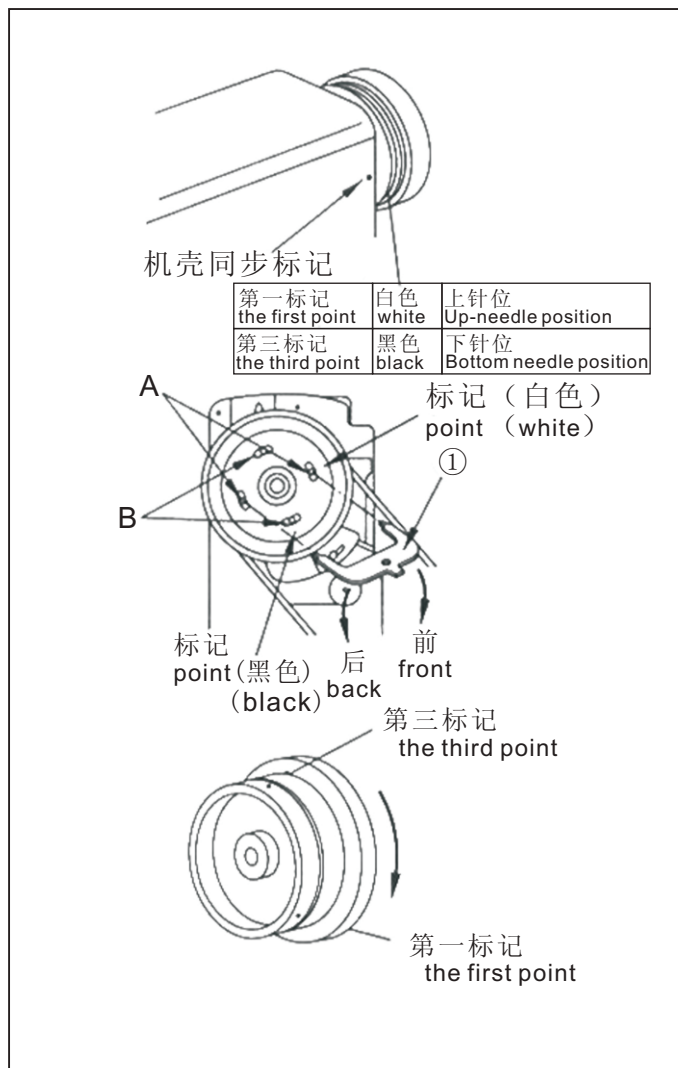

### 1. 上针位的调整

当脚跟踩下踏板剪线后，机器应停在上针位。如标记偏差大于3mm，作如下调整：

- (1) 切断电源。
- (2) 转动手轮，使手轮上的第一个标记点与机壳上的标记点对齐，松开螺钉①调整停针磁钢，使传感器指示灯亮时，紧锁螺钉①。
- (3) 开动机器试车。

EN

### 1. The adjustment of the upper needle position

The needle should be in the upper position after stepping on the pedal to active the trimming. The adjustment should be made as below if the mark deviation is more than 3mm

- (1) Switch off the electrical power
- (2) Rotate the hand wheel to make the first mark point of the hand wheel be in line with the mark point in the chassis, then loose the screw. (1)adjust the needle position magnetic steel to turn on the indicator light of the sensor, then twist the screw
- (3) Start the machine to have a trial run

## 19. 接线 Connecting the wire

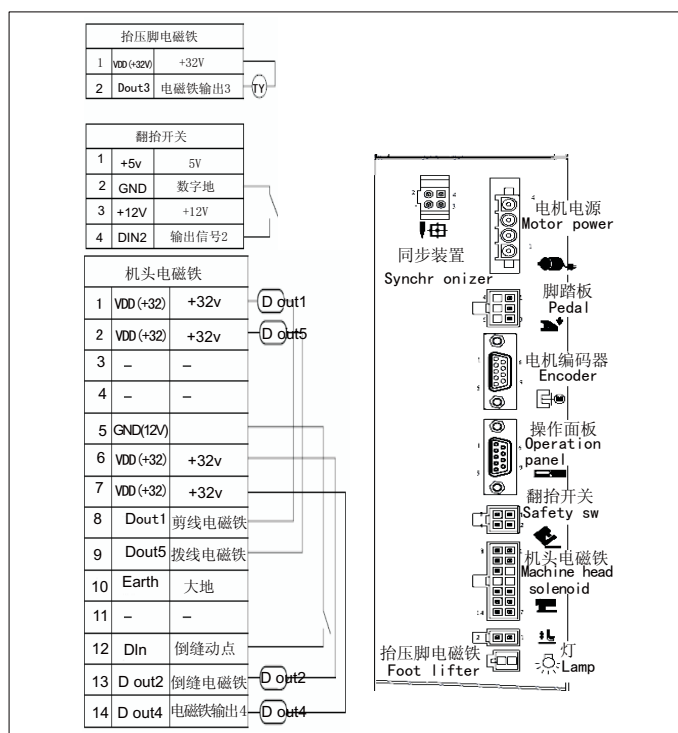

## 20. 剪线机构的调整 Adjusting for thread trimmer (自动剪线型)

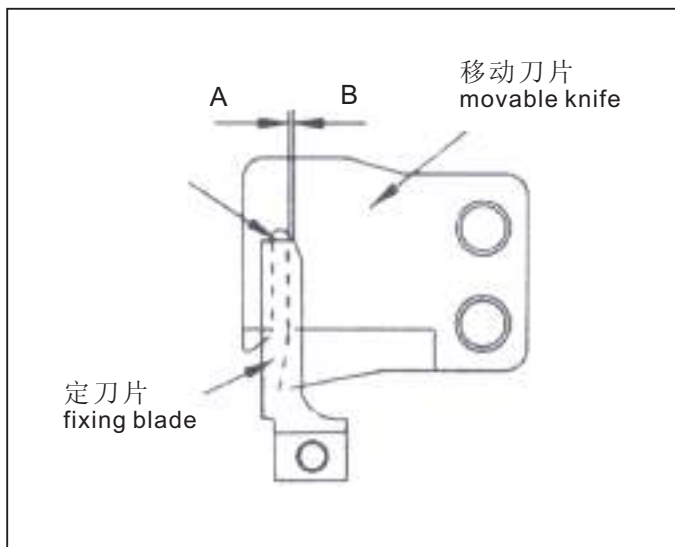
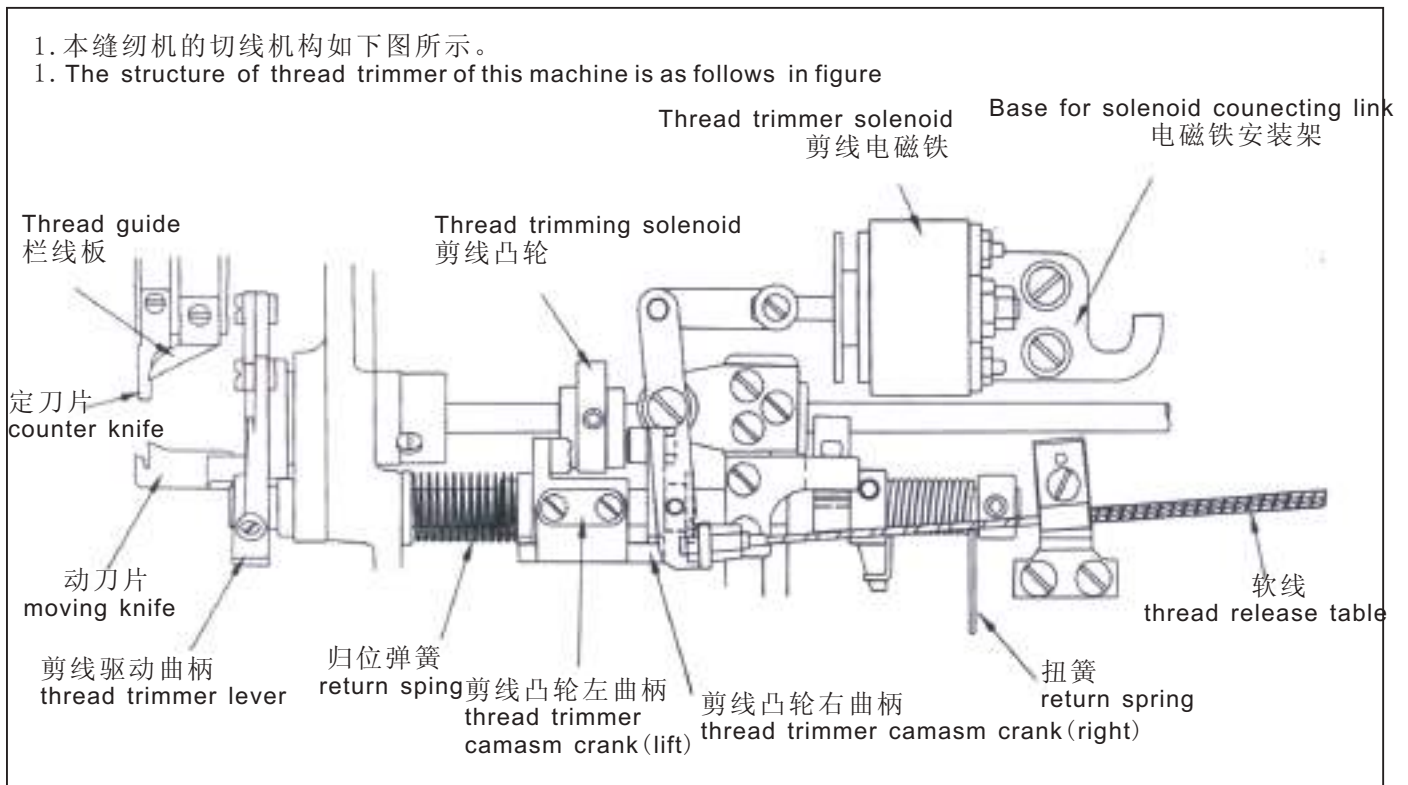

EN

### 2. Adjusting fixing blade and movable knife

(1) Like in Figure , the standard position is where the cut part of the movable knife is aligned with the center of the fixed blade.

(2) When part A becomes bigger in figure, three pieces of threads are to be produced, causing the thread missing after the trimming. If part B becomes bigger, it can cause a trimming miss.

So be cautious in adjusting the right position.

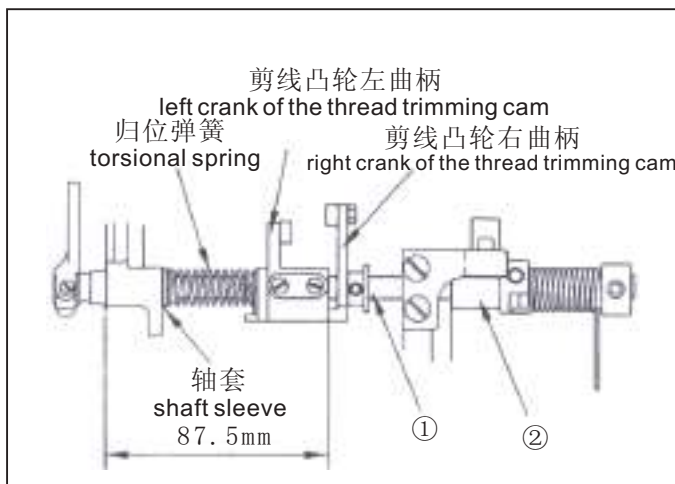

EN

### 3. Adjusting the crank of the thread trimming cam

(1) While assembling, users should first set the crank shaft of the thread trimming cam on the platform.

(2) The left and right crank must be set on the flat of the thread trimming shaft referring to the Figure.

(3) Gently rotate the trimming shaft①, and set the set block② on the flat of the trimming shaft①.

## 20. 剪线机构的调整 Adjusting for thread trimmer (自动剪线型)

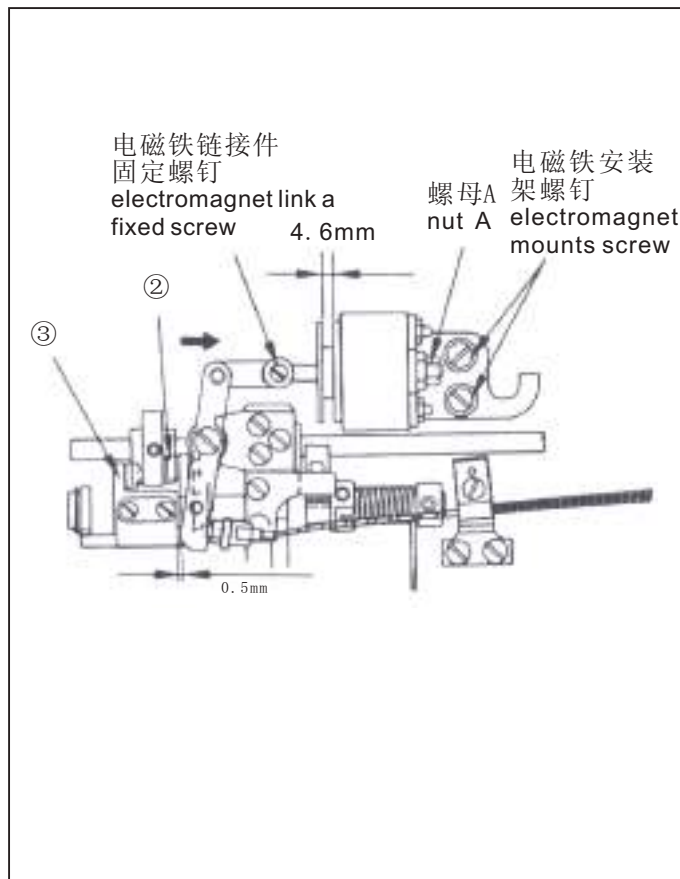

### 4. 安装剪线电磁铁

(1) 剪线电磁铁的行程:

- A. 标准的行程为4.6mm.
- B. 通过调节螺母A来调整行程。

(2) 剪线电磁铁的调整

- A. 电磁铁的安装位置以电磁铁工作时，凸轮左曲柄③与凸轮右曲柄②之间有0.5mm间隙为标准。
- B. 如需调整，可按图所示箭头方向移动电磁铁安装架。

EN

### 4. installation of thread trimmer

(1) working amount of the thread trimming solenoid.

- A. The standard working amount of the thread trimming solenoid is 4.6mm.

B. By adjusting the nut to adjust A trip.

(2) adjusting the thread trimming solenoid

- A. if you run the solenoid under this circumstance, a gap of 0.5mm occurs between the left crank ③ and the right crank ②. This state is the standard.

B. If you need to adjust. Can be shown as shown in figure and direction of arrow mobile electromagnet mounts.

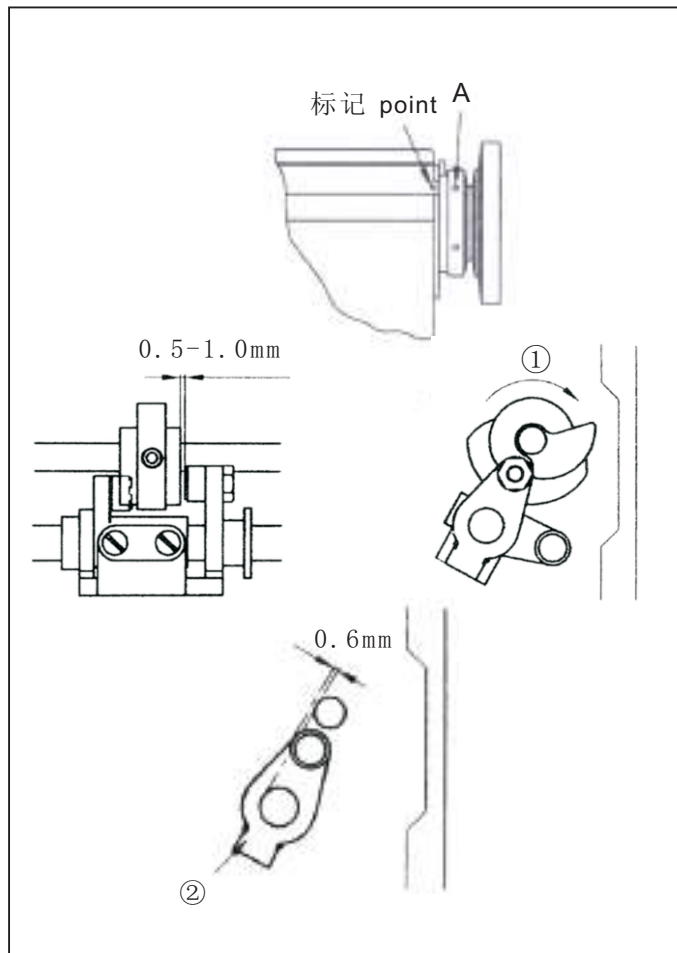

### 5. 安装剪线凸轮

(1) 将主动轮上的第2标记点对准机壳上的定位标记点。

(2) 在启动剪线电磁铁状态下，朝正方向回转剪线凸轮①直到接触滚柱，然后固定凸轮。

(3) 剪线电磁铁关闭，使凸轮曲柄②恢复到原始置，这样凸轮与滚柱端面将以0.5-1.0mm间隙为标准。

EN

### 5 .Installation of thread trimming cam

(1) Align the second timing carved line of the pulley with the arm's carved line.

(2) Under the thread trimming solenoid is in operation, rotate the trimming cam ① clockwise and fix the cam when it connected with the roller.

(3) When the thread cam following crank returned by stopping the operation of the thread trimming solenoid, the edge end between the cam and the roller should be from 0.5 to 1.0mm. It is the standard.

## 20. 剪线机构的调整 Adjusting for thread trimmer(自动剪线型)

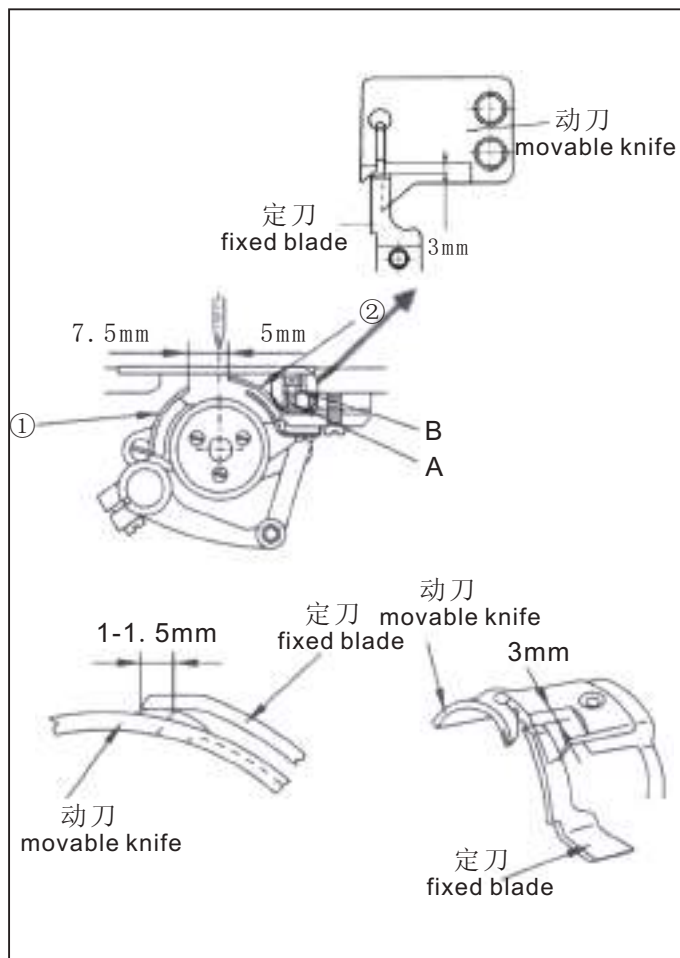

### 6. 刀片位置调整

#### (1) 动刀与定刀的位置调整:

如图所示,动刀①与机针中心的距离为7.5mm,定刀②与机针中心的距离为5mm。

#### (2) 动刀移动量调整:

开动电磁铁,启动机器.剪线凸轮会使动刀①向右旋转。当动刀①移动到其最远位置时,其断面定刀②的端点进行到1.0mm-1.5mm。

#### (3) 刀片压力调整:

A. 如图所示,动刀和定刀开始接触为标准状态。

B. 如果剪线情况不良,尤其当线较粗时,只需增加定刀张力即可。

C. 定刀张力可调整: 松开螺母B, 通过调节螺钉A来调节螺母B。

**EN**

### 6. Adjusting the position of blade

#### (1) Adjusting the position of the movable knife ① and the fixed blade ②

The standard position of the movable knife is 7.5mm from the needle center, and 5 mm for the fixed blade.

#### (2) Adjusting the progress amount of the movable knife

If you run the machine putting the solenoid in the operation mode, the movable knife ① will rotate by the thread trimming cam. The standard will be where the cut part of the movable knife ① progresses 1.0 to 1.5mm from the end edge of the fixed blade ② when the progress amount of the movable knife is in its maximum.

#### (3) Adjusting blade pressure

A. As in Figure, the standard is when the contact between the movable knife and the fixed blade begins.

B. In particular, when the cutting quality gets worse by using a thick thread, strengthen a little bit the tension of the fixed blade.

C. In order to adjust the tension of the fixed blade, loosen the tension adjustment nut with the wrench box and adjust the tension using the tension adjustment bolt.

## 21. 定期清洁机器 Regular cleaning machine

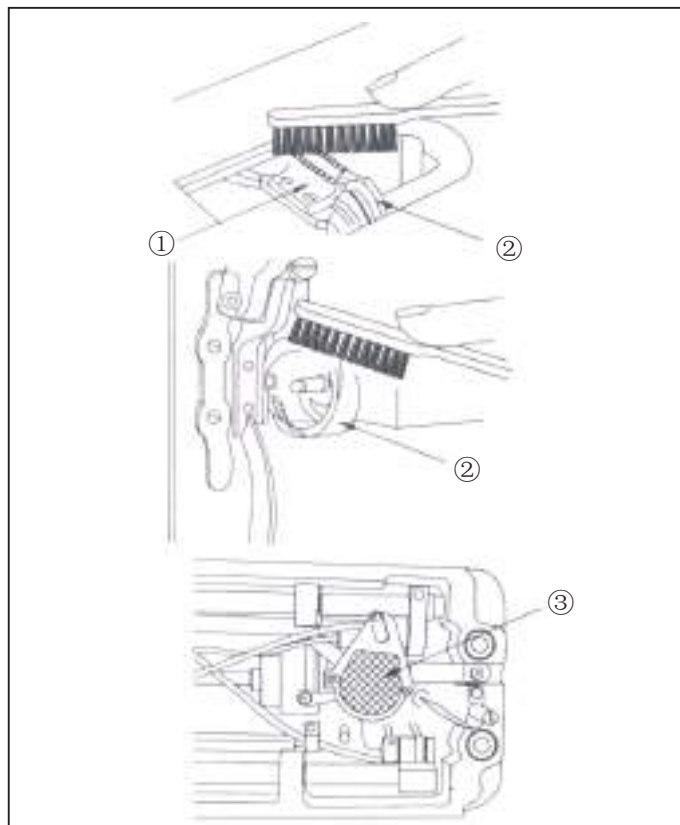

定期清扫送布牙①、旋梭②和油泵③。

**EN**

Regular cleaning feed dog ①, hook ② and pump hook ③.

## 22. 故障原因及对策

### 缝纫机故障处理方法

编号	故障状态	确认事项	故障原因	处理事项
1	断针	针的方向、高度	插针方向不好	把针向正确的方向重新插入，紧贴到最上端
		针	针弯	换针
		锯齿定时	对针杆运动的锯齿定时不好	调整锯齿定时
		针杆提升量	针与旋梭的定时不好	调整针与旋梭的定时
		针杆高度	针与旋梭的定时不好	调整针与旋梭的定时
		针与锯齿之间的缝隙	针与旋梭的定时不好	调整针与旋梭的定时
2	断线	穿线状态	穿线错误	正确穿线
		针	针弯，针尖动了	换针
		针的方向、高度	插针位置不好	向正确方向插针
		面线张力	面线张力过大	适当调整面线张力
		底线张力	底线张力过大	适当调整底线张力
		挑线器弹簧工作量	工作量过大	调整弹簧工作量
3	穿线状态不良	线张力	面线底线张力不好	调整上下线的张力
		挑线器弹簧张力	挑线器弹簧张力不适当	调整挑线器弹簧张力
		开松机和旋梭间的缝隙	开松机和旋梭间的缝隙不好	调整开松机和旋梭间的缝隙
4	缝纫开始时，面线掉出或跳针	针的方向、高度	插针位置不好	向正确方向插针
		针	针弯，针尖动了	换针
		穿线方法	穿线错误	正确穿线
		针与旋梭间的缝隙	针与旋梭的定时不好	调整针与旋梭的定时
		切线后的面线余量	针上的面线余量过短	把控制面板的面线余量调整幅度调大
		底线把	切线后，底线把无法蓄住底线	适当调整底线把的位置及张力
		针上面停止位置确认	针上面停止位置不好，缝纫开始时，挑线器把面线拉出去	针上面停止时，重新调整胶片位置
5	不能切线	动刀片与旋梭间的缝隙	动刀片与旋梭高度及距离不符合	重新调整动刀片的设定位置
		固定刀片张力确认	动刀片与固定刀片的张力及接触状态不好	调好动刀片与固定刀片的张力及接触状态
		针方向	插针状态不好	正确插针
		动刀片、固定刀片刀刃	动刀片、固定刀片刀刃有毛病或磨损	交换动刀片、固定刀片
		切线凸轮定时	切线凸轮定时不对	调整切线凸轮定时
		线松开工作量	线松开工作量过少	重新调整线松开工作量
6	切线结束后缝线余量过短	切线定时	切线定时不对	调整切线定时
		线张力调整碟的开量	线张力调整碟的开量过小	调整线松开工作量
		辅助线张力调整装置张力	辅助线张力调整装置张力过大	调整辅助线张力
		挑线器弹簧工作量	挑线器弹簧工作量过大	调整挑线器弹簧工作量
		控制面板的线松开调整幅度	幅度调整得过小	把幅度调大

## 22. Causes of troubles and troubleshshooting

### Sewing machine troubleshooting

No	Symptom	Checkpoints	Root cause	Corrective action
1	Needle breaks	Direction and height of needle	Needle is inserted into wrong position	Reinsert the needle correctly
		Needle	Needle is bent	Change the needle
		Timing of feed dog	Bad timing of feed dog	Adjust the timing of feed dog
		Ascending level of needle bar	Bad timing of needle and hook	Adjust the timing of needle and hook
		Height of needle	Bad timing of needle and hook	Adjust the timing of needle and hook
		Gap between needle and hook	Bad timing of needle and hook	Adjust the timing of needle and hook
2	Thread breaks	Threading method	Wrong threading	Thread the needle correctly
		Needle	Bent needle or broken needle tip	Change the needle
		Direction and height of needle	Needle inserted in the wrong position	Insert the needle correctly
		Upper thread tension	Too tight upper thread tension	Reduce tension of upper thread
		Lower thread tension	Too tight lower thread tension	Reduce tension of lower thread
		Working capacity of take-up lever spring	Loose upper thread	Adjust take-up lever spring
3	Poor thread adjustment	Thread tension	Upper and lower thread tensions are bad	Adjust the upper and lower thread tensions
		Thread take up spring tension	Thread take up spring tension is inadequate	Adjust the thread take up spring tension
		Gap between opener and hook	The gap between the opener and hook is inadequate	Adjust the gap between the opener and hook
4	Upper thread falls out when starting to sew or sewing is skipped.	Direction and height of needle	Needle is inserted into wrong position	Reinsert the needle correctly and push in to its highest level.
		Needle	Needle is bent	Change the needle
		Threading	Wrong direction	Insert the thread in the right way.
		Gap between the needle and the hook	The timing between the needle and hook is bad	Adjust the timing between the needle and hook
		Remaining upper thread length after trimming	The length of the remaining upper thread is too short	Increase the adjustment volume of the upper thread on the control box
		Lower thread holder	After trimming, lower thread holder does not hold the lower thread	Adjust the location and tension of the lower thread holder.
		Check the up-stop position of the needle	Due to problems in the up-stop position of the needle, the thread take up lever pulls the upper thread out of the needle when the sewing starts	Readjust the needle's up-stop film position
5	Trimming miss	The gap between the movable knife and the hook	The height and distance between the movable knife and the hook do not match	Readjust the movable knife setting position
		Check the tension of fixed knife	Tension and contact of movable and fixed knives are bad	Correct the tension adjustment and surface contact of movable and fixed knives.
		Direction of the needle	Needle is not inserted correctly	Insert the needle correctly
		Blade side of movable and fixed knives	Scratch and abrasion of movable and fixed knives	Replace movable knife or fixed knife.
		Trimming cam timing	The timing of trimming cam is wrong	Adjust the timing of trimming cam
		Thread release stroke	Thread release stroke is too small	Readjust the thread release stroke
6	Too short thread length after trimming	Trimming timing	Wrong trimming timing	Adjust the trimming timing
		Opening of the thread tension adjusting plate	The opening on the thread tension control plate is too small	Adjust the thread release stroke
		Tension of auxiliary thread tension adjustment assembly	Too strong tension on the auxiliary thread tension control assembly	Adjust the tension of the auxiliary thread tension control assembly
		Thread take up stroke	Thread take up stroke is too large	Adjust the thread take up stroke
		Thread release adjustment volume on the control box	Volume is adjusted to too low	Increase the volume adjustment.





# 1. 机壳部件 Frame Components

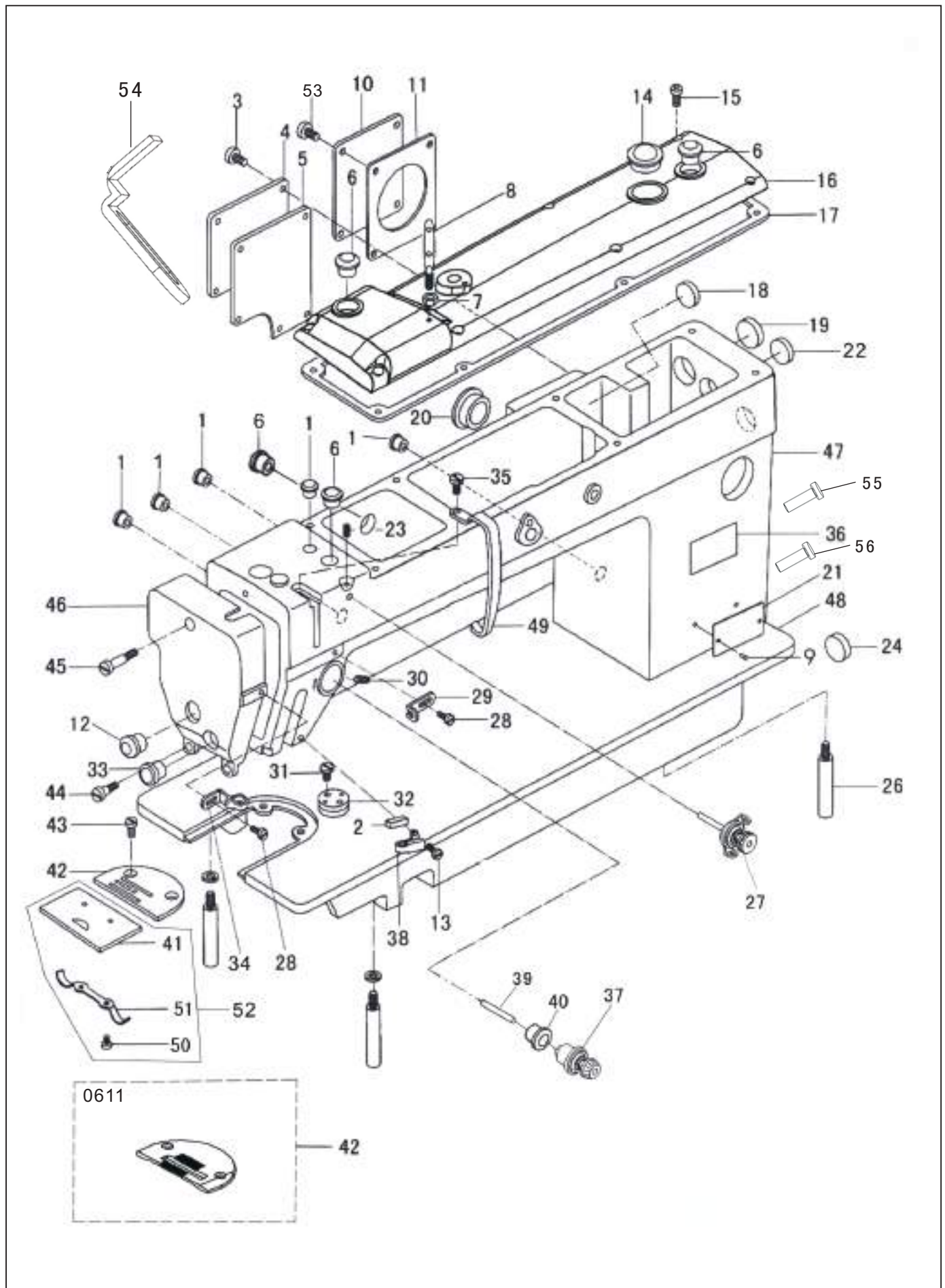

# 1. 机壳部件 Frame Components

序号 NO.	图号 REF NO.	名称	DESCRIPTION	数量 AMT	备注 NOTE
1	120-02-16	橡皮塞	Rubber plug φ8.8	5	
2	193-01-42	下过线勾毛毡	Oil felt	1	
3	11-40110825-01	后盖板螺钉	Screw SM11/64×40 L=8	9	
4	1300-01-04	侧盖板	Back cover	1	
5	1300-01-05	侧盖板垫片	Gasket for back cover	1	
6	120-01-30	橡皮塞	Rubber plug φ19	3	
7	13-60113020-02	过线杆螺母	Upper thread guide pin nut	1	
8	1300-01-08	过线杆	Upper thread guide pin	1	
9	101-01-14	铭牌铆钉	Model plate rivet	2	
10	1300-01-10B	后盖板	Side plate	1	0311/0611专用
11	1300-01-11	后盖板垫片	Side plate gasket	1	
12	120-01-30	橡皮塞	Rubber plug φ19	1	
13	11-70090720-02	下线勾螺钉	Screw SM9/64×40 L=6	1	
14	114-01-20	油窗组件	Oil sight window ASM	1	
15	11-40111025-01	上盖板螺钉	Screw SM11/64×40 L=10	8	
16	1300-01-16	上盖板	Top cover	1	
17	1300-01-17	上盖板垫片	Gasket for top cover	1	
18	1300-01-22	橡皮塞	Rubber plug φ22	1	
19	1300-01-19	橡皮塞	Rubber plug φ29	1	
20	1300-01-20	橡皮塞	Rubber plug φ26	1	
21	1300-01-21	型号牌	Model plate	1	
22	1300-01-30	橡皮塞	Rubber plug φ23	1	
23	11-80110910-01	小夹线器支紧螺钉	Set screw SM11/64×40 L=8.5	1	
24	120-01-20	橡皮塞	Rubber plug φ27	1	
26	5590-01-15	底板撑杆	Bed leg	4	
27	409-11-01	小夹线器组件	Thread tension ASM no.1	1	
28	11-70090720-02	线勾螺钉	Screw SM9/64×40 L=6	2	
29	120-01-18	机壳线勾	Arm thread guide	1	
30	11-80150710-01	夹线调节座固定螺钉	Screw SM15/64×28 L=7	1	
31	11-00110520-01	夹边座螺钉	Screw SM11/64×40 L=5.5	2	
32	101-01-17	夹边座	Connecting rod	1	
33	120-01-06	面板橡皮塞	Face rubber plug φ11.8	1	
34	120-01-07	面板线勾	Thread guide on face plate	1	
35	11-40110625-01	挑线杆防护罩螺钉	Screw type tension stud SM11/64×40 L=6	1	
36	44-00000001-00	安全指示牌	Safety label	1	
37	1300-01-37	夹线器组件	Thread tension ASM.	1	
38	1300-01-38	下过线勾	Arm thread guide plate(low)	1	
39	1300-01-39	松线杆	Tension releasing pin	1	
40	1300-01-40	夹线器密封套	Plug	1	
41	1300-01-54	推板	Slide plate	1	
42	1300-01-55	针板	Needle plate	1	0311系列专用
	1301-01-55	针板	Needle plate	1	0611系列专用
43	11-20110920-02	针板螺钉	Screw SM11/64×40 L=9	2	
44	11-60112020-01	面板螺钉	Screw SM11/64×40 L=20	2	
45	11-70113020-01	面板上螺钉	Screw SM11/64×40 L=30	1	
46	1300-01-59	面板	Face plate	1	
47	1300-01-60	车壳	Arm	1	0311系列专用
	1300-01-60B	车壳	Arm	1	0611系列专用
48	1300-01-61	底板	Bed	1	0311系列专用
	1300-01-61B	底板	Bed	1	0611系列专用
49	1300-01-62	挑线杆防护罩	Thread take-up lever cover	1	
50	11-60060220-01	推板簧螺钉	Screw SM3/32×56 L=2	2	
51	120-01-25	推板簧	Slide plate spring	1	
52	1300-01-54-00	推板组件	Slide plate ASM.	1	
53	11-40111225-01	侧盖板螺钉	Screw	4	
54	1273.12-05	直角电线夹	Rectangular wire clamp	1	0311-7 0611-7专用
55	11-40111025-01	皮带罩固定螺钉2	Screw	1	
56	11-40151525-01	皮带罩螺钉	Screw	1	

## 2. 挑线勾线部件 Thread Take-up & Thread Components

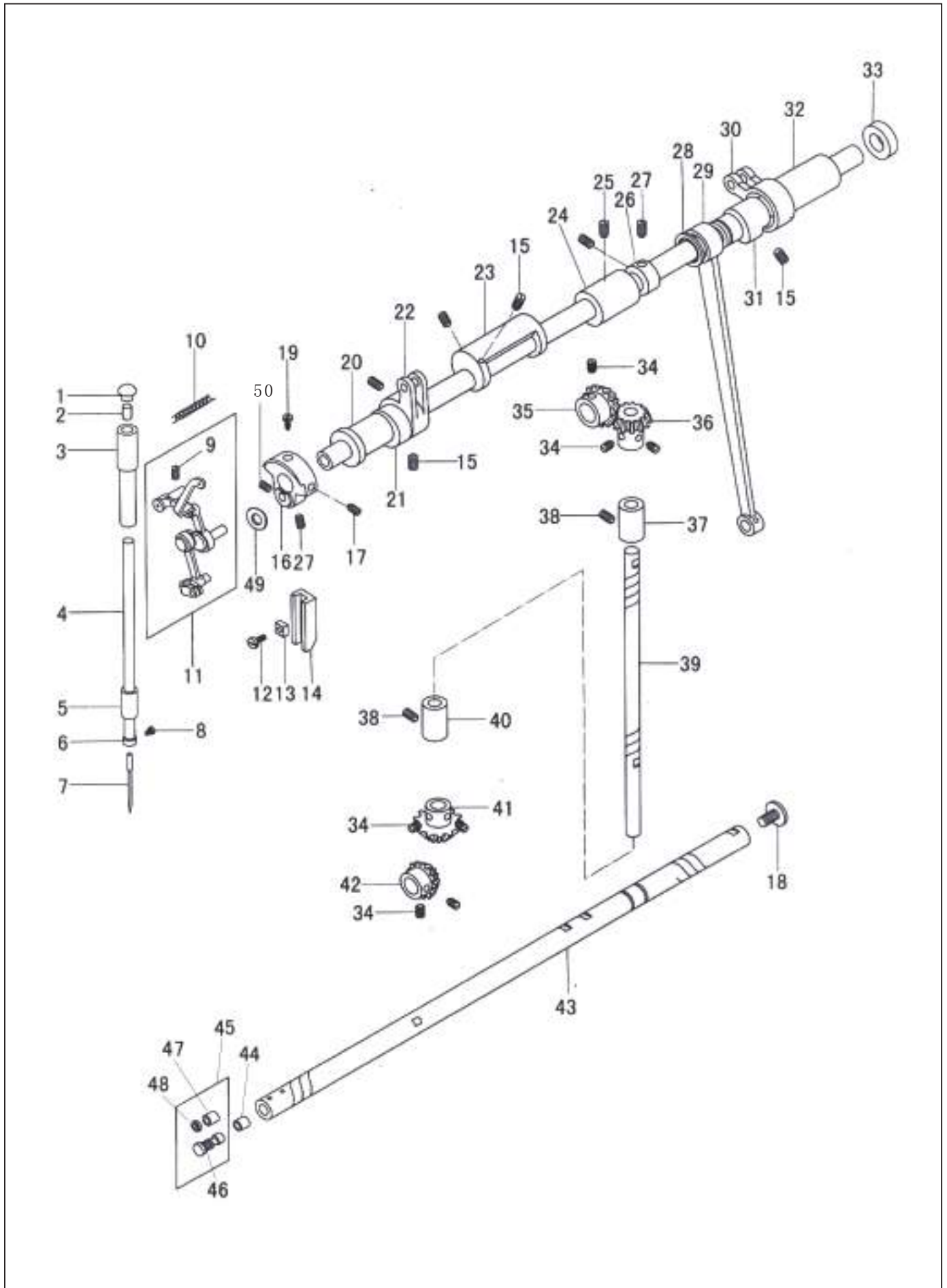

## 2. 挑线勾线部件 Thread Take-up & Thread Components

序号 NO.	图号 REF NO.	名称	DESCRIPTION	数量 AMT	备注 NOTE
1	120-02-16	针杆上轴套橡皮塞	Needle bar bushing(upper)rubber plug $\phi 8.8$ L=7	1	0311系列专用
2	120-02-15	针杆上轴套毛毡	Felt plug	1	0311系列专用
3	120-02-14	针杆上轴套	Needle bar bushing(upper)	1	0311系列专用
4	1300-02-04	针杆	Needle bar	1	
5	1300-02-05	针杆下轴套	Needle clamp	1	0311系列专用
6	120-02-20	针杆过线环	Thread guide for needle bar	1	
7	1300-02-07	机针 DP×17 #23	Needle	1	
8	11-60080520-01	机针螺钉	Needle clamp screw SM1/8×44 L=4.5	1	
9	11-80111420-01	挑线连杆铰链轴螺钉	Set screw	1	
10	43-10300000-00	挑线连杆铰链轴油线	Oil wick $\phi 2.5$ L=250	0.25	
11	1300-02-11	挑线杆大组件	Thread take-up lever ASM	1	
12	11-60110820-01	滑块导轨螺钉	Set screw SM11/64×40 L=8	2	0311系列专用
13	120-02-25	针杆接头滑块	Slide block	1	0311系列专用
14	120-02-23	针杆接头滑块导轨	Guide for slide block	1	0311系列专用
15	11-80160710-01	平衡块螺钉	Screw SM1/4×40 L=7	5	
16	1300-02-16	针杆曲柄	Needle bar crank	1	
17	11-80181650-01	针杆曲柄螺钉	Set screw SM9/32×28 L=16	1	
18	11-70221020-01	上轴油封螺钉	Set screw SM11/32×28 L=10	1	
19	1300-02-19	针杆曲柄定位螺钉	Set screw SM9/32×28 L= 11.5	1	
20	1300-02-20	上轴前套	Upper shaft front bushing	1	
21	1300-02-21	送布凸轮（左）	Feed lifting cam(left)	1	
22	1300-02-22	送布凸轮曲柄（左）	Feed lifting cam crank(left)	1	
23	1300-02-23	平衡块	Balance cam	1	
24	1300-02-24	上轴中轴套	Arm shaft bushing(middle)	1	
25	11-80150810-01	上轴中轴套螺钉	Set screw SM15/64×28 L=7.5	1	
26	101-02-33	上轴紧圈	Collar for arm shaft	1	
27	11-80160510-01	上轴紧圈螺钉	Set screw SM1/4×40 L=5	2	
28	25-20000000-08	轴用挡圈 $\phi 20 \times 1.2$	Snap ring $\phi 20 \times 1.2$	1	
29	1300-02-29	拾牙连杆	Feed lifting rod	1	
30	1300-02-30	送布凸轮曲柄（右）	Feed lifting cam crank (right)	1	
31	1300-02-31	送布凸轮（右）	Feed lifting cam(right)	1	
32	1300-02-32	上轴后轴套	Upper shaft rear bushing(rear)	1	
33	32-14170300-09	上轴后轴套油封	Oil seal	1	
34	11-80160710-01	伞齿轮螺钉	Gear screw SM1/4×40 L=7	(8)	
35	101-05-26	上轴伞齿轮	Bevel gear for arm shaft	1	
36	101-05-25	竖轴伞齿轮(上)	Bevel gear for vertical shaft(upper)	1	
37	1300-02-37	竖轴上轴套	Vertical shaft bushing (upper)	1	
38	11-80150812-01	竖轴轴套支头螺钉	Set screw SM15/64×28 L=6	2	
39	1300-02-39	竖轴	Vertical shaft	1	
40	1300-02-40	竖轴下轴套	Vertical shaft bushing (lower)	1	
41	101-05-20	竖轴伞齿轮(下)	Bevel gear for vertical shaft(lower)	1	
42	101-05-18	下轴伞齿轮	Bevel gear for hook shaft	1	
43	1300-02-44	上轴	Arm shaft	1	0311D/0611D不用
	1301-02-44	上轴	Main shaft	1	0311D/0611D专用
44	101-02-11	羊毛毡垫	Roller felt	1	
45	1300-02-46	油量调节杆组件	Fuel lever asm.	1	
46	1300-02-46-01	油量调节杆	Fuel lever	(1)	
47	101-02-13	油量调节圈	Sleeve of oil amount adjusting pin	(1)	
48	31-03618000-09	O型圈	Rubber ring	(2)	
49	21-08010122-03	针杆曲柄垫片	Washer	1	
50	11-80160612-01	挑线曲柄螺钉	Screw	2	

### 3. 下送料部件 Feed Mechanism Components

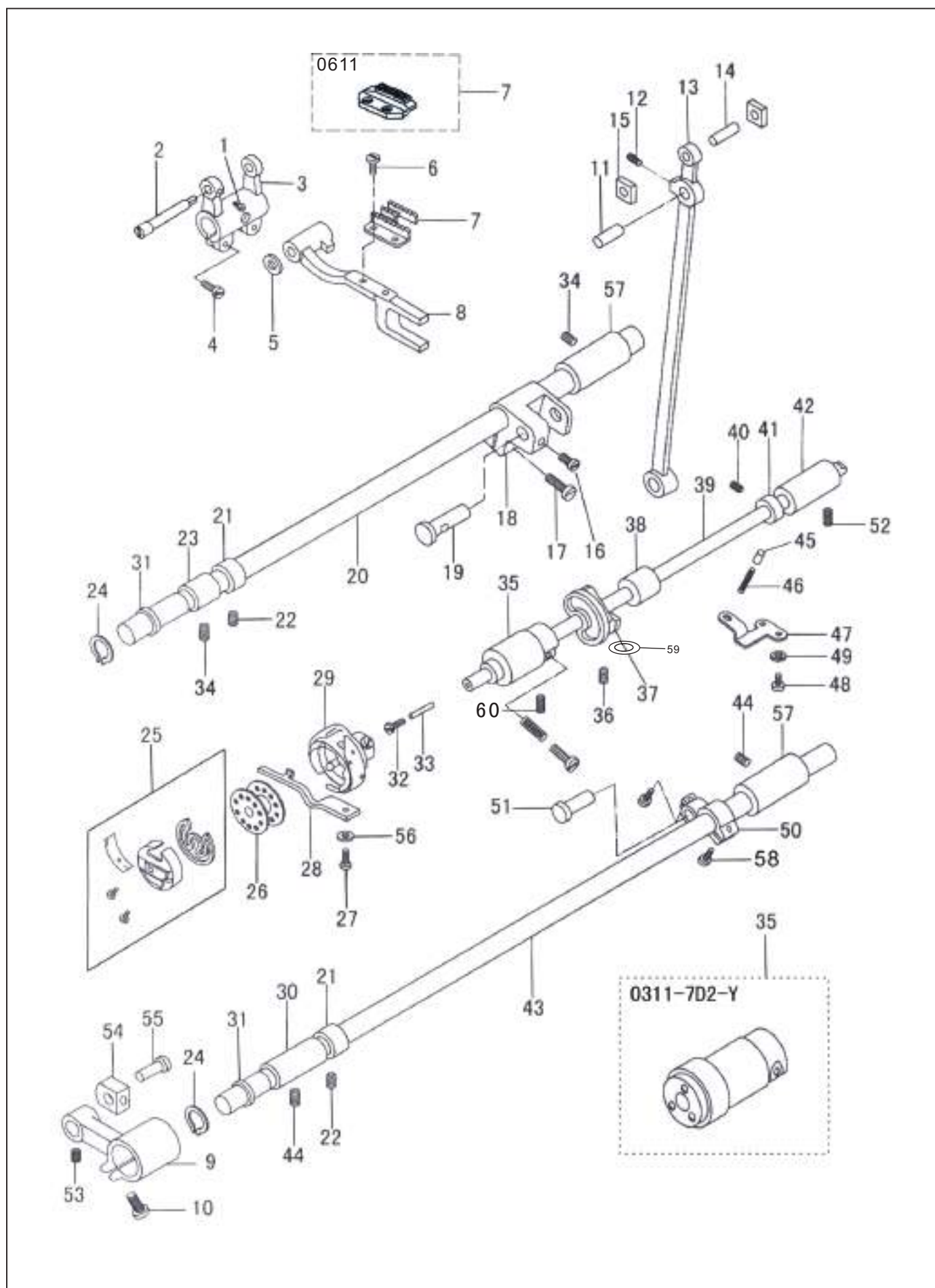

### 3. 下送料部件 Feed Mechanism Components

序号 NO.	图号 REF NO.	名称	DESCRIPTION	数量 AMT	备注 NOTE
1	11-40110625-01	牙架轴螺钉	Screw SM11/64×40 L=6	1	
2	120-04-06	牙架曲柄偏心轴	Eccentricity shaft for feed bar	1	
3	120-04-01	牙架曲柄	Feed rock shaft crank	1	
4	11-00121520-01	送布轴曲柄螺钉	Screw SM3/16×28 L=15	2	
5	21-06113102-03	牙架曲柄轴垫圈	Washer φ10×φ6 L=1.3	1	
6	11-60080620-01	送布牙螺钉	Screw SM1/8×44 L=6	2	
7	1300-03-07	送布牙	Feed dog	1	
	1301-03-07	送布牙	Feed dog	1	0311系列专用
8	120-04-03	牙架	Feed bracket	1	0611系列专用
9	1300-03-09	抬牙曲柄(前)	Feed lifting rock shaft crank(front)	1	
10	11-00121520-01	抬牙曲柄(前)螺钉	Set screw SM3/16×28 L=15	1	
11	1300-03-11	送布连杆销(下)	Pin for (short)	1	
12	11-80110512-01	送布连杆销螺钉	Set screw SM11/64×40 L=5	1	
13	1300-03-13	针距曲柄连杆	Feed connecting rod	1	
14	1300-03-14	送布连杆销(上)	Slide block shaft	1	
15	1300-03-15	送布滑块	Slide block	2	
16	11-60150720-01	送布曲柄销螺钉	Set screw SM15/64×28 L=7	1	
17	11-40151525-01	送布曲柄销螺钉	Set screw SM15/64×28 L=15	1	
18	1300-03-18	送布曲柄(右)	Feed rock shaft crank(right)	1	
19	1300-03-19	送布曲柄销	Hinge pin	1	
20	1300-03-20	送布轴	Feed rock shaft	1	
21	101-02-06	送布轴紧圈	Thrust collar	2	
22	11-80160510-01	送布轴紧圈螺钉	Screw screw SM1/4×40 L=5	4	
23	120-04-28	送布轴前轴套	Feed rock shaft bushing(front)	1	
24	25-15000000-08	轴用弹性挡圈	Snap ring	2	
25	1222-05-02	梭心套组件	Bobbin case	1	
26	120-02-72	梭心	Bobbin	1	0311/0611专用
	1222-05-03	梭心(铝)	Bobbin(aluminum)	1	0311/0611不用
27	11-70111120-01	旋梭定位勾螺钉	Rotating hook positional screw SM11/64×40 L=11	1	
28	120-02-69	旋梭定位勾	Rotating hook positional	1	
29	1222-05-01	旋梭组件	Rotating hook complete	1	自动剪线不用
	1300-03-29	旋梭组件	Rotating hook complete	1	自动剪线用
30	1300-03-30	抬牙轴轴套	Feed lifting rock shaft bushing	1	
31	21-15020212-03	抬牙轴轴套垫圈	Washer	2	
32	101-05-08	下轴滤油塞螺钉	Set screw	1	
33	101-05-09	下轴滤油塞	Oil wick	1	
34	11-80150510-01	送布轴轴套支头螺钉	Screw SM15/64×28 L=4.5	2	
35	1300-03-35	下轴前套	Hook shaft bushing(front)	1	0311/0611不用
	1300-03-35B	下轴前套	Hook shaft bushing(front)	1	0311/0611专用
36	11-80161012-01	剪线凸轮螺钉	Screw SM1/4×40 L=10	2	
37	1300-03-37	剪线凸轮	Thread trimmer cam	1	0311/0611不用
38	1300-03-38	下轴中套	Hook shaft(middle)	1	
39	1300-03-39	下轴	Hook shaft	1	
40	11-00110520-01	下轴紧圈螺钉	Screw SM11/64×40 L=4.5	2	
41	101-05-16	下轴紧圈	Collar for hook shaft	1	
42	120-02-62	下轴右轴套	Hook shaft bushing(right)	1	
43	1300-03-43	抬牙轴	Feed lifting rock shaft	1	
44	11-80151310-01	抬牙轴轴套支头紧螺钉	Screw SM15/64×28 L=13	2	
45	120-02-64	柱塞	Plunger	1	
46	120-02-65	柱塞弹簧	Plunger spring	1	
47	120-02-66	挡板	Guide plate	1	
48	11-60151020-01	挡板螺钉	Screw SM15/64×28 L=10	1	
49	22-06000000-08	挡板螺钉弹簧垫圈	Washer	1	
50	1300-03-50	抬牙轴曲柄	Feed lifting rock shaft crank	1	
51	1300-03-51	抬牙轴曲柄铰链销	Feed lifting rock shaft crank	1	
52	11-80151010-01	下轴后轴套支头螺钉	Screw SM15/64×28 L=10	1	
53	11-40110625-01	牙架滑块轴支头螺钉	Screw SM11/64×40 L=6	1	
54	120-04-24	抬牙叉滑块	Slide block pin	1	
55	1300-03-55	抬牙叉滑块轴	Slide block pin shaft	1	
56	22-05000000-08	旋梭定位勾螺钉弹簧垫片	Feed lifting rock shaft bushing (rear)	1	
57	1300-03-57	送布抬牙轴后轴套	Bushing	2	
58	11-40621425-01	抬牙轴曲柄螺钉	Screw SM3/16×32 L=14	2	
59	1230.09-40	剪线凸轮螺钉垫片	Washer	2	0311-7 0611-7专用
60	11-80150810-01	下轴前轴套支头螺钉	Screw	1	

#### 4. 针距调节部件 Feed Adjust Mechanism Components

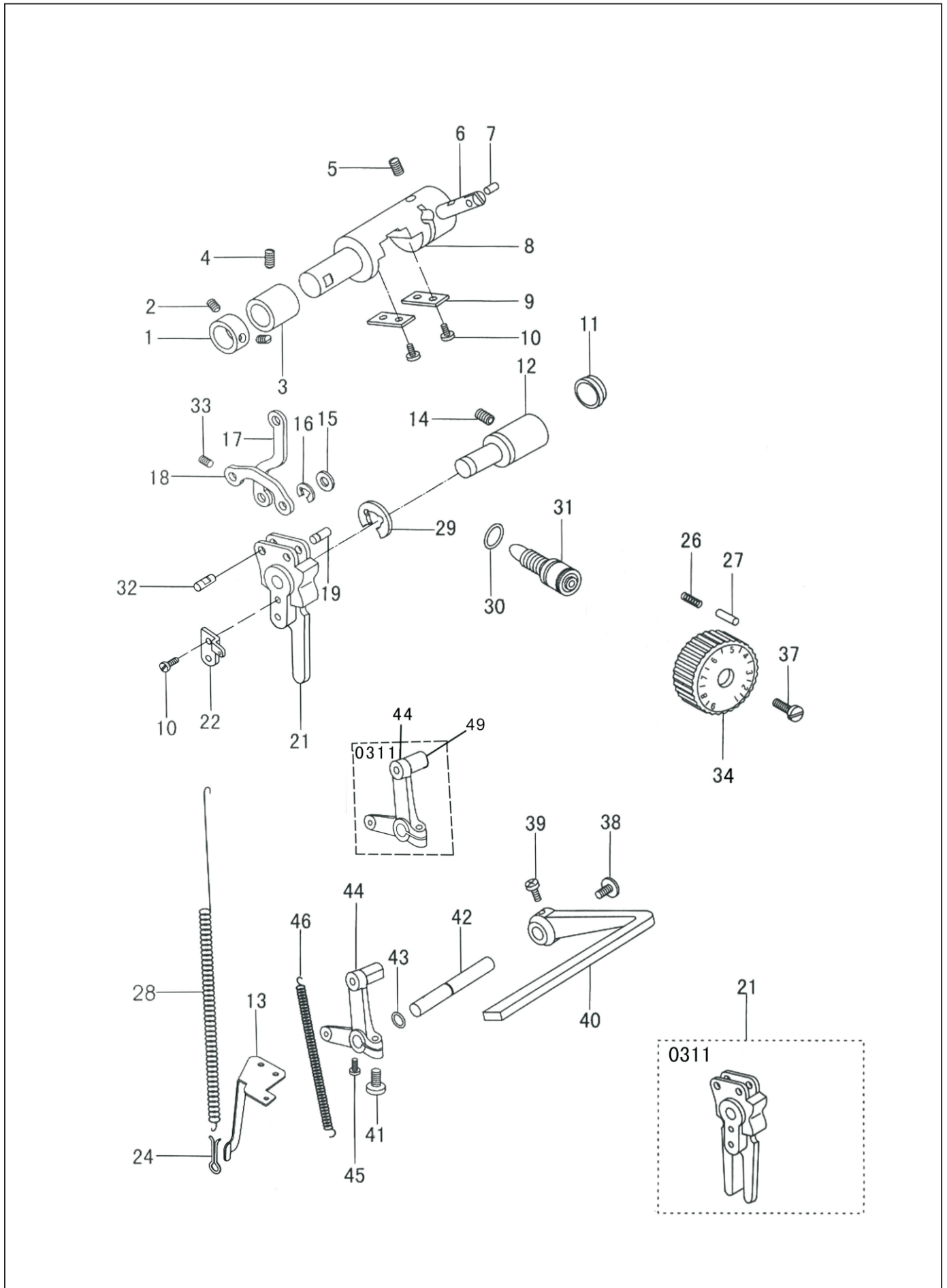

#### 4. 针距调节部件 Feed Adjust Mechanism Components

序号 NO.	图号 REF NO.	名称	DESCRIPTION	数量 AMT	备注 NOTE
1	101-02-06	倒缝台紧圈	T hrust collar	1	
2	11-80160510-01	倒缝台紧圈螺钉	Screw SM1/4×40 L=5	2	
3	120-04-13	倒缝台轴套	Feed regulator shaft bushing	1	
4	11-80151010-01	倒缝台轴套螺钉	Screw SM15/64×28 L=10	1	
5	11-80151010-01	支撑轴螺钉	Screw SM15/64×28 L=10	1	
6	1300-04-06	支撑轴	Reverse shaft for feed regulator shaft	1	
7	1300-04-07	支撑轴销	Connecting pin	1	
8	1300-04-08	倒缝台	Feed regulator shaft	1	
9	1300-04-09	倒缝台导向板	Slide block guide plate	2	
10	11-40110825-01	倒缝台导向板螺钉	Screw SM11/64×40 L=7.5	6	
11	101-01-02	橡皮塞	Rubber plug φ20	1	
12	1300-04-12	针距调节摆杆铰链轴	Hinge pin for regulatop	1	
13	1300-04-13	拉簧架	Bracket for spring	1	
14	11-80151010-01	针距调节摆杆铰链轴轴套螺钉	Screw SM15/64×28 L=10	1	
15	1300-04-15	针距连杆垫圈	Washer	1	0311/0611不用
16	24-04000000-08	针距连杆挡圈	Retaining ring φ4	1	0311/0611不用
17	1300-04-17	针距连杆	Connecting rod for feed regulator shaft	1	
18	1300-04-18	倒缝连杆	B/t solenoid crank	1	0311/0611不用
19	1300-04-19	针距连杆销	Feed link pin	1	0311/0611不用
21	1300-04-21B	针距调节摆杆	Feed regulator	1	0311/0611专用
	1300-04-21	针距调节摆杆	Feed regulator	1	0311/0611不用
22	1300-04-22	小拉簧架	Bracket for spring(small)	1	
24	1300-04-24	拉簧勾	Spring hook	1	
26	101-07-06	标盘止动销弹簧	Plunger spring	1	
27	423.09-26	止动销	Stopper pin	1	
28	1300-04-28	倒缝操纵杆拉簧	Spring for feed regulator	1	
29	24-07000000-09	针距调节摆杆轴挡圈	Retaining ring φ7	1	
30	31-09624000-09	针距调节摆杆密封圈	Rubber ring	1	
31	1300-04-31	针距调节螺杆	Feed regulator screw	1	
32	1300-04-32	针距连杆销	Feed link pin	1	
33	12-80400512-01	针距连杆紧固螺钉	Screw M4 L=5	1	
34	1300-04-34	针距标盘	Dial	1	
37	11-70121820-01	标盘螺钉	Screw SM3/16×28 L=18	1	
38	120-03-21	倒缝扳手紧固螺钉	Screw SM3/16×28 L = 6.5	1	
39	11-60121820-01	倒缝扳手螺钉	Screw SM3/16×28 L=18	1	
40	1300-04-40	倒缝扳手	Reverse feed control lever	1	
41	11-40121625-01	倒缝扳手曲柄夹紧螺钉	Screw SM3/16×28 L=16	1	
42	1300-04-42	倒缝扳手短轴	Reverse feed lever shaft	1	
43	31-05018000-09	倒缝扳手短轴密封圈	Rubber ring	1	
44	1300-04-44	倒缝扳手曲柄组件	Reverse feed crank ASM	1	0311/0611不用
	1300-04-44B	倒缝扳手曲柄组件	Reverse feed crank pin	1	0311/0611专用
45	11-40110825-01	倒缝扳手短轴紧固螺钉	Screw SM11/64×40 L=8	1	
46	120-03-27	倒缝扳手曲柄弹簧	Spring for reverse feed crank	1	
49	1300-04-49	橡胶套	Rubber bushing	1	0311/0611不用



## 5.压脚摆动部件 Hand Swing Components

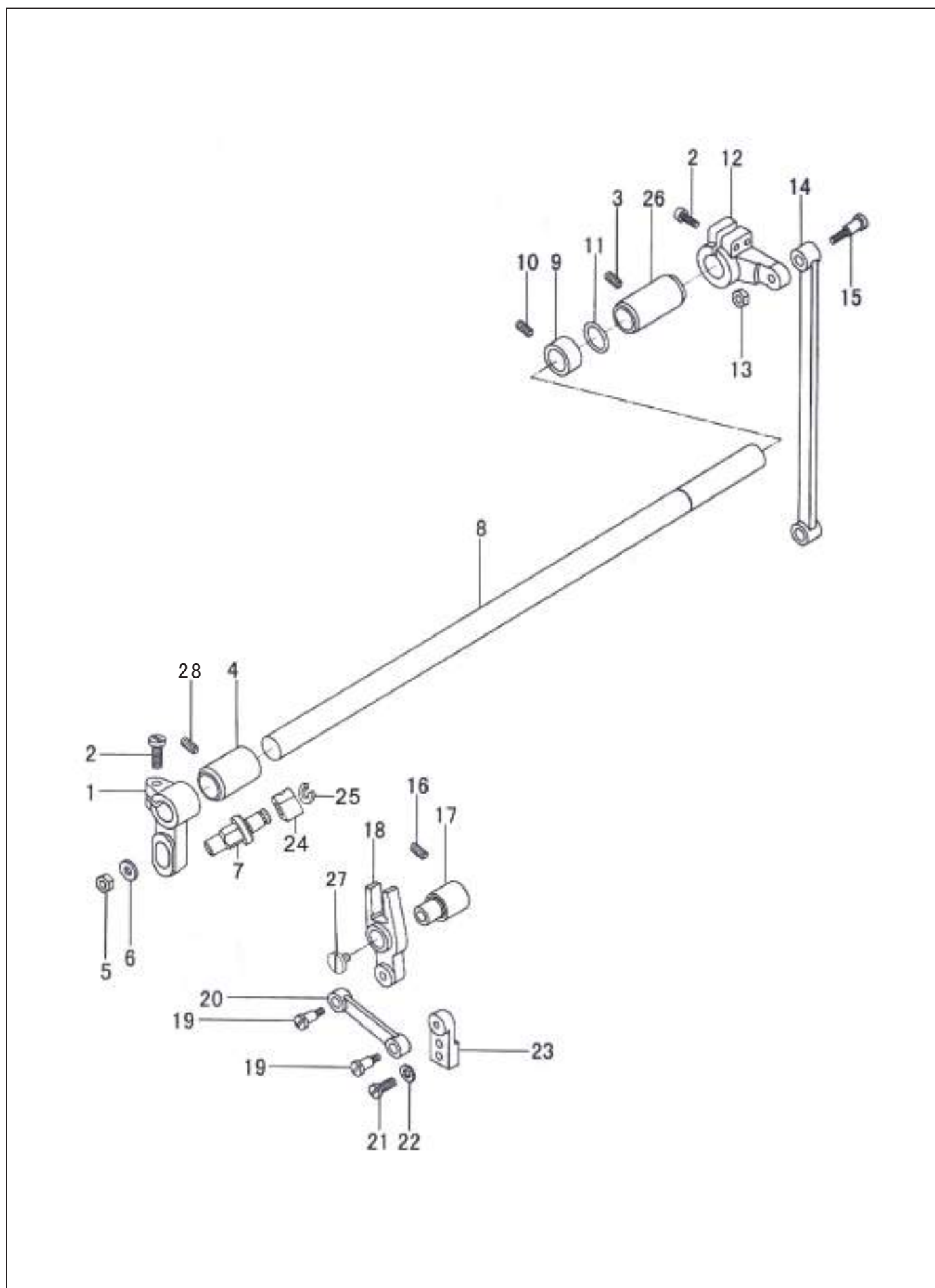

## 5.压脚摆动部件 Hand Swing Components

序号 NO.	图号 REF NO.	名称	DESCRIPTION	数量 AMT	备注 NOTE
1	1300-05-01	压脚摆动左曲柄	Upper feed lever level adjusting crank	1	
2	11-40151525-01	压脚摆动曲柄螺钉	Screw SM15/64×28 L=15	2	
3	11-80150510-01	压脚摆动后轴套螺钉	Screw SM15/64×28 L=5	1	
4	1300-03-57	压脚摆动前轴套	Bushing (front)	1	
5	13-60114020-01	压脚曲柄连接螺母	Nut	1	
6	21-06113102-03	垫圈	Washer	1	
7	120-06-39	提升压脚变动曲柄轴	Lifting presser sway crank	1	
8	1300-05-08	压脚摆动轴	Presser swing crank	1	
9	101-02-06	摆动轴紧圈	Thrust collar	1	
10	11-80160510-01	紧圈螺钉	Screw SM1/4×40 L=5	2	
11	31-10020000-09	O型圈	O ring	1	
12	1300-05-12	压脚摆动右曲柄	Crank (right)	1	
13	13-60184020-01	提升压脚调节螺母	Lifting presser adjusting screw nut	1	
14	1300-05-14	压脚摆动右曲柄连杆	Presser swing(right) crank rod	1	
15	1300-05-15	压脚摆动右曲柄连杆螺钉	Presser swing(right) crank rod screw	1	
16	11-80150510-01	提升压脚变动曲柄导柱螺钉	Screw SM15/64×28 L=15	1	
17	1300-05-17	提升压脚变动曲柄导柱	Lifting presser sway crank guide pin	1	
18	1300-05-18	提升压脚变动曲柄	Upper feed level driving link	1	
19	120-06-28	提升压脚连杆螺钉	Set screw	2	
20	1300-05-20	提升压脚变动连杆	Upper feed level driving rod	1	
21	11-40090725-01	摆动连杆座螺钉	Screw SM9/64×40 L=7	2	
22	22-04000000-08	摆动连杆座螺钉弹簧垫圈	Spring washer φ4	2	
23	1300-05-23	摆动连杆座	Presser rod guide	1	
24	120-06-60	提升压脚变动曲柄滑块	Lifting presser sway crank block	1	
25	24-04000000-08	挡圈	Ring φ4	1	
26	1300-05-26	压脚摆动后轴套	Presser swing shaft bushing(rear)	1	
27	11-70151020-01	螺钉	Screw SM15/64×28 L=10	1	
28	11-80150710-01	压脚摆动前轴套螺钉	Screw	1	

## 6. 压脚提升部件 Hand Lifter Components

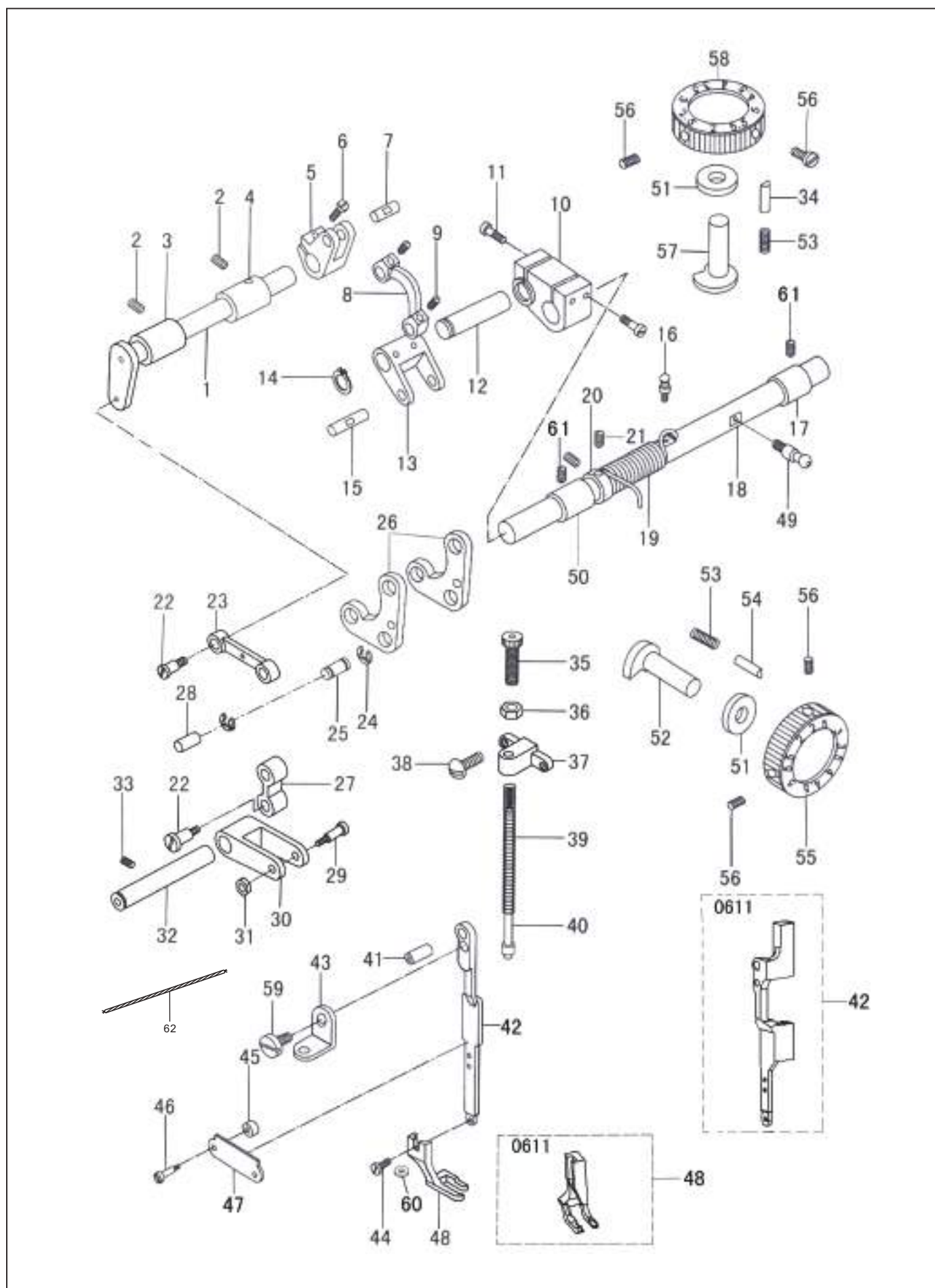

## 6. 压脚提升部件 Hand Lifter Components

序号 NO.	图号 REF NO.	名称	DESCRIPTION	数量 AMT	备注 NOTE
1	1300-06-01	压脚提升轴	Presser lifting shaft	1	
2	11-80150710-01	提升轴轴套螺钉	Screw SM15/64×28 L=7	2	
3	1300-06-03	压脚提升轴左轴套	Upper feed driving shaft bushing(left)	1	
4	1300-06-04	压脚提升轴右轴套	Upper feed driving shaft bushing(right)	1	
5	1300-06-05	提升轴调节曲柄	Upper feed driving crank	1	
6	11-60151460-01	提升轴调节曲柄螺钉	Screw SM15/64×28 L=14	1	
7	1300-06-07	提升轴调节曲柄轴	Connecting pin	1	
8	1300-06-08	提升轴调节曲柄连杆	Upper feed driving connecting link	1	
9	11-80110512-01	提升轴调节曲柄连杆螺钉	Screw SM11/64×40 L=5	2	
10	1300-06-10	压脚提升轴支架	Upper feed driving control crank	1	
11	11-60111520-01	压脚提升轴支架螺钉	Screw SM11/64×40 L=16	4	
12	1300-06-12	压脚提升轴支架轴	Connecting shaft	1	
13	1300-06-13	压脚提升轴支架轴曲柄	Climb device adjusting shaft	1	
14	25-10000000-08	压脚提升轴支架轴挡圈	Snip ring	1	
15	1300-06-15	压脚提升轴支架曲柄轴	Connecting pin	1	
16	1300-06-16	压脚提升调节轴螺钉	Set screw	1	
17	1300-06-17	压脚提升调节轴后轴套	Climb device adjusting shaft bushing(rear)	2	
18	1300-06-18	压脚提升调节轴	Climb device adjusting shaft	1	
19	1300-06-19	压脚提升调节轴弹簧	Return spring	1	
20	101-02-06	压脚提升调节轴紧圈	Thrust collar	1	
21	11-80160510-01	压脚提升调节轴紧圈螺钉	Screw SM11/4×40 L=5	2	
22	120-06-28	压脚送料曲柄连杆螺钉	Set screw	2	
23	1300-06-23	压脚送料曲柄连杆	Upper feed driving rod	1	
24	24-06000000-08	E型挡圈	E-ring	2	
25	1300-06-25	送料曲柄铰链轴(上)	Upper feed connecting link pin	1	
26	1300-06-26	压脚送料曲柄	Upper feed connecting link	2	
27	1300-06-27	送料曲柄连杆	Presser bar bracket connecting link	1	
28	1300-06-28	送料曲柄铰链轴(下)	Lower feed connecting link pin	1	
29	1300-06-29	送料曲柄连杆螺钉	Set screw	1	
30	1300-06-30	压脚送料曲柄支架	Upper feed lever rock crank	1	
31	13-60153320-01	送料曲柄连接螺母	Nut	1	
32	1300-06-32	送料曲柄轴	Upper feed lever rock crank shaft	1	
33	11-80151010-01	曲柄螺钉	Screw SM15/64×28 L=10	1	
34	1300-06-34	止动销	Stopper pin	1	
35	120-06-01	摆压脚调压螺钉	Lifting presser adjusting screw	1	
36	13-60183620-01	摆压脚调压螺母	Lifting presser adjusting nut	1	
37	1300-06-37	提升压脚弹簧架	Frame	1	
38	11-40110825-01D	提升压脚弹簧架固定螺钉	Screw SM11/64×40 L=7.5	2	
39	120-06-19	提升压脚簧	Lifting presser spring	1	
40	1300-06-40	调压杆弹簧导柱	Upper feed pressure adjusting spring bar	1	
41	1300-06-41	压脚连杆轴套	Upper feed lever connecting pin	1	
42	1300-06-42	压脚连杆	Presser rod	1	0311系列专用
	1301-06-42	压脚连杆	Presser rod	1	0611系列专用
43	1300-06-43	提升压脚导柱架	Fulcrum	1	
44	11-70090820-01	压脚螺钉	Screw SM9/64×40 L=8	1	
45	120-06-46	压脚连杆压板垫块	Space for presser rod plate	2	
46	11-60111220-01	连杆压板螺钉	Screw SM11/64×40 L=12	2	
47	120-06-47	提升压脚连杆压板	Lifting presser rod plate	1	
48	1300-06-48	外压脚组件	Outside presser ASM	1	0311系列专用
	122-06-45	外压脚	Outside presser	1	0611系列专用
49	1300-06-49	压脚提升调节轴螺钉	Set screw	1	
50	1300-06-50	压脚提升调节前轴套	Climb device adjusting shaft bushing(front)	1	
51	21-10130180-01	压脚位置调节盘垫片	Washer	2	
52	1300-06-52	压脚位置调节凸轮(长)	Climb device eccentric cam(long)	1	
53	120-02-65	止动销弹簧	Spring	2	
54	1300-06-34	止动销 φ3.6	Stopper pin	1	
55	1300-06-55	压脚位置调节盘(机壳)	Climb device dial ASM.(arm )	1	
56	11-80151010-01	自由式凸轮支头螺钉	Screw SM15/64×28 L=10	4	
57	1300-06-57	压脚位置调节凸轮(短)	Climb device eccentric cam(short)	1	
58	1300-06-58	压脚位置调节盘	Climb device dial ASM.(top cover)	1	
59	1300-06-59	导柱架螺钉	Set screw	1	
60	21-04608080-01	外压脚弹簧垫片	Washer	1	
61	11-80110610-01	提升调节轴轴套螺钉	Set screw	2	
62	43-20300000-00	油线	Oil wick	0.45	

# 7. 压脚部件 Presser Lifting Mechanism

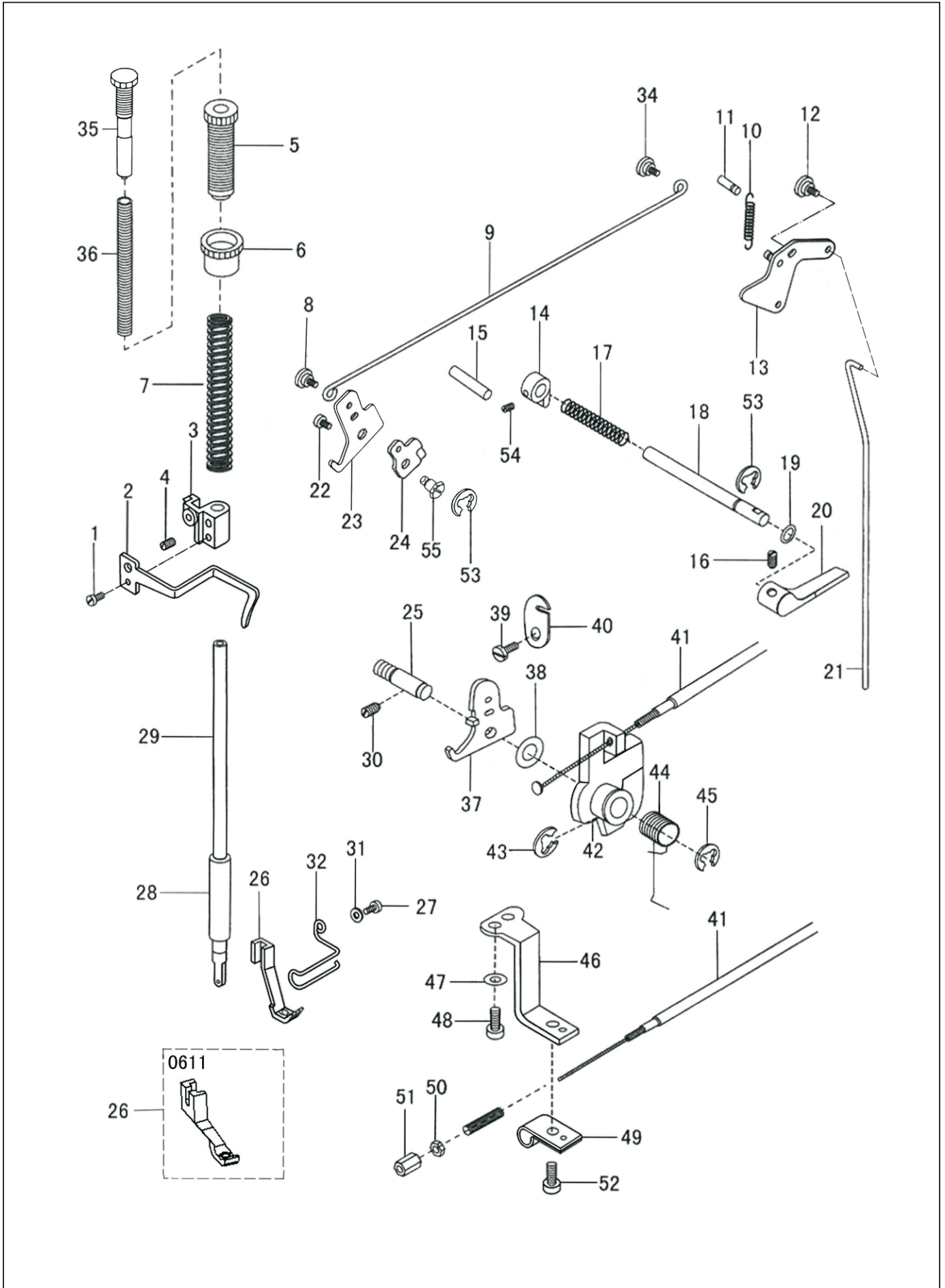

## 7. 压脚部件 Presser Lifting Mechanism

序号 NO.	图号 REF NO.	名称	DESCRIPTION	数量 AMT	备注 NOTE
1	11-00110520-01	大线勾螺钉	Screw SM11/64×40 L=5	1	
2	1300-07-02	大线勾	Upp thread guide	1	
3	1300-07-03	压紧杆导架	Presser bar bushing	1	
4	11-80150810-01	压紧杆导架螺钉	Screw SM15/64×28 L=7.5	1	
5	1300-07-05	调压螺钉	Pressure regulating thumb screw	1	
6	1300-07-06	调压螺钉锁紧螺母	Nut for pressure adjusting screw	1	
7	120-05-21	压紧杆弹簧	Presser bar spping	1	
8	101-04-32	膝控提升拉杆螺钉	Hinge screw	1	
9	1300-07-09	膝控提升拉杆	Knee lifter rod	1	
10	1300-07-10	膝控提升拉杆(右)弹簧	Spring of knee lifter lever	1	
11	120-05-16	弹簧销	Spring of pin	1	
12	120-05-14	膝控提升拉杆(右)螺钉	Screw SM15/64×28 L=7	1	
13	1300-07-13	膝控提升杠杆组件	Knee lifter lever ASM.	1	
14	1300-07-14	压紧杆提升凸轮	Presser bar lifting cam	1	
15	1300-07-15	压紧杆提升凸轮限位销	Stopper pin for presser lifter cam	2	
16	11-80150510-01	压脚扳手螺钉	Screw SM15/64×28 L =4.5	2	
17	1300-07-17	压脚扳手轴弹簧	Torsion spring for presser bar lifter shaft	1	
18	1300-07-18	压脚扳手轴	Presser bar lifter shaft	1	
19	31-04018000-09	压脚扳手轴O型圈	O-ring for presser bar lifter shaft	1	
20	1300-07-20	压脚扳手	Hand lifter	1	
21	1300-07-21	膝控提升连杆	Knee lifting bar stick	1	
22	11-60110721-01	膝控提升杠杆(左)螺钉	Screw SM11/64×40 L=6.5	1	0311/0611专用
23	1300-07-23B	膝控提升杠杆(左)	Presser bar lifting link(left)	1	0311/0611专用
24	120-05-06	松线板	Tension releasing	1	0311/0611专用
25	1300-07-25	松线轴	Shaft for tension pelease plate ASM.	1	0311/0611不用
26	1300-07-26	内压脚	Sub press foot	1	0311系列专用
	122-05-27	内压脚	Sub press foot	1	0611系列专用
27	11-60091120-01	压脚螺钉	Press foot screw SM9/64×40 L=11	1	
28	1300-07-28	压杆套	Presser bar bushing	1	
29	1300-07-29	压杆	Presser bar	1	
30	11-80090610-01	松线板销螺钉	Screw SM9/64×40 L=6	1	
31	21-04210080-02	防护勾垫片	Washer	1	
32	1300-07-32	防护勾	Presser bar shield	1	
34	120-05-08	铰链螺钉	Hinge screw	1	
35	1300-07-35	辅助调压螺钉	Sub pressure adjusting screw	1	
36	1300-07-36	辅助调压弹簧	Sub pressure adjusting spring	1	
37	1300-07-23B	膝控提升杠杆(左)	Presser bar lifting link(left)	1	0311/0611用
	1300-07-23	膝控提升杠杆(左)	Presser bar lifting link(left)	1	0311-7/0611-7用
38	21-06106100-01	松线轴垫片	Washer	1	0311/0611不用
39	11-40090525-01	软线夹(上)螺钉	Screw SM9/64×40 L=4.5	1	0311/0611不用
40	1300-07-40	软线夹(上)	Tension release cable holder(upper)	1	0311/0611不用
41	1300-07-41	松线钢绳组件	Tension release cable ASM.	1	0311/0611不用
42	1300-07-42	松线板组件	Tension release plate ASM.	1	0311/0611不用
43	24-08000000-08	松线板卡簧	Snap ring	1	0311/0611不用
44	1300-07-44	松线弹簧	Spring for tension release plate ASM.	1	0311/0611不用
45	24-05000000-08	松线轴挡圈	Snap ring	1	0311/0611不用
46	1300-07-46	软线夹固定架(下)	Bracket (lower)	1	0311/0611不用
47	21-04508080-01	软线夹(下)固定架螺钉垫片	Washer	2	0311/0611不用
48	12-40401025-01	软线夹(下)固定架螺钉	Screw M4 L=10	2	0311/0611不用
49	1300-07-49	软线夹(下)	Tension release cable holder(lower)	1	0311/0611不用
50	14-60504020-02	软线螺母	Nut M5 H=4	1	0311/0611不用
51	14-60504020-02	软线锁紧螺母	Nut M5 H=4	(1)	0311/0611不用
52	12-40401025-01	软线夹(下)螺钉	Screw M4 L=10	1	0311/0611不用
53	24-06000000-08	卡簧	Ring	2	0311/0611不用
54	11-80160610-01	提升凸轮螺钉	Screw SM1/4×40 L=6	1	0311/0611不用
55	1300-07-25B	膝控提升杠杆销	Presser bar lifting link pin	1	0311/0611专用

8. 剪线部件 Feed Adjust Mechanism Components For 0311-7D2-Y and 0611-7D2-Y

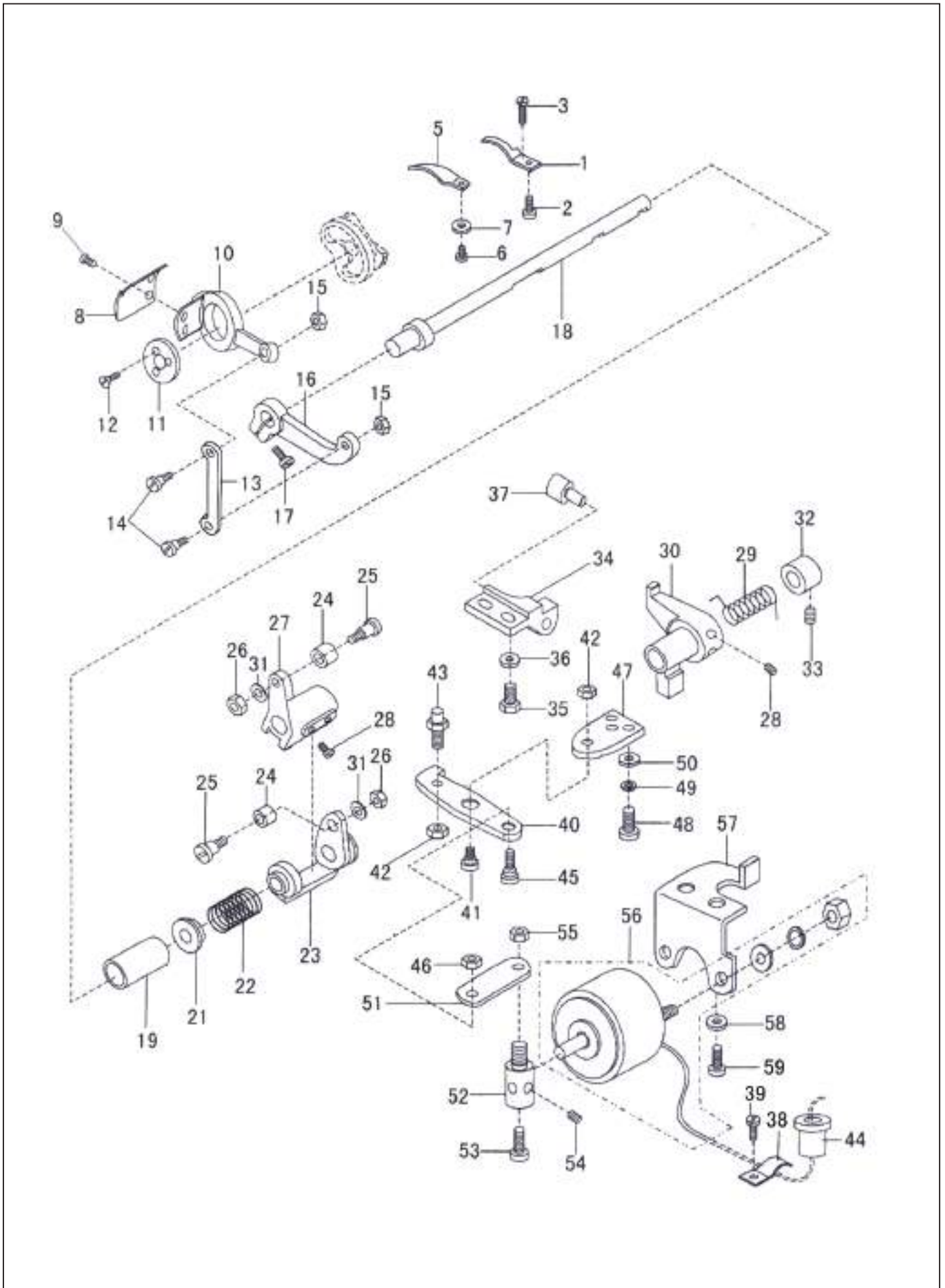

## 8. 剪线部件 Feed Adjust Mechanism Components For 0311-7D2-Y and 0611-7D2-Y

序号 NO.	图号 REF NO.	名称	DESCRIPTION	数量 AMT	备注 NOTE
1	1300-08-01	定刀片	Counter knife	1	
2	11-10090620-01	定刀片螺钉	Counter knife screw SM9/64×40 L=6	1	
3	11-80090412-01	定刀调节螺钉	Counter knife adjusting screw SM9/64×40 L=6	2	
5	1300-08-05	栏线板	Thread guide	1	
6	11-40090725-01	栏线板螺钉	Thread guide screw SM11/64×40 L=8	1	
7	21-04808080-01	栏线板螺钉垫片	Thread guide screw washer	1	
8	1300-08-08	动刀片	Moving knife	1	
9	11-10110622-01	动刀片紧固螺钉	Screw SM11/64×40 L=5.5	2	
10	1300-08-10	刀架	Thread trimming holder	1	
11	1300-08-11	刀架垫片	Thread trimming holder washer	1	
12	11-10090720-01	刀架螺钉	Thread trimming holder screw SM9/64×40 L=7	3	
13	1300-08-13	刀轴连杆	Thread trimming lever connecting link	1	
14	1300-08-14	刀轴连杆螺钉	Thread trimming lever connecting link screw	2	
15	13-60623020-01	刀轴连杆螺母	Nut SM3/16×32 H=3	2	
16	1300-08-16	剪线驱动曲柄	Thread trimming lever	1	
17	12-60601522-01	驱动曲柄螺钉	Thread trimming lever screw M6 L=15	1	
18	1300-08-18	剪线轴	Thread trimming shaft	1	
19	1300-08-19	剪线轴轴套	Thread trimming shaft bushing	1	
21	1300-08-21	扭簧端盖	Guide bush for return spring	1	
22	1300-08-22	归位弹簧	Slide arm return spring	1	
23	1300-08-23	剪线凸轮右曲柄	Thread trimmer cam asm crank (right)	1	
24	1300-08-24	滚轮	Roller	2	
25	1300-08-25	滚轮螺钉	Roller screw SM3/16×32 L=6	2	
26	13-60623020-01	滚轮螺母	Roller nut SM3/16×32 H=3	2	
27	1300-08-27	剪线凸轮左曲柄	Thread trimmer cam asm crank (left)	1	
28	11-80150812-01	左曲柄螺钉	Crank(left) screw SM15/64×28 L=8	2	
29	1300-08-29	凸轮轴扭簧	Return spring	1	
30	1300-08-30	限位块	Stopper lever	1	
31	22-05000000-08	弹簧垫片	Spring washer φ5	2	
32	279-04-37	凸轮轴紧圈	Collar for thread trimming shaft	1	
33	11-80110512-01	紧圈螺钉	Collar screw SM11/64×40 L=5	2	
34	1300-08-34	限位板	Stopper board	1	
35	11-90621323-01	限位板螺钉	Stopper board screw SM3/16×32 L=13	2	
36	21-05310100-02	限位板螺钉垫片	Stopper board screw washer φ5	2	
37	1300-08-37	缓冲橡胶	Stopper lever cushion rubber	1	
38	124-11-37	线夹	Cord holder	1	
39	11-40090625-01	线夹螺钉	Screw SM9/64×40 L=6	1	
40	1300-08-40	离合器杆	Clutch lever	1	
41	1300-08-41	离合器杆螺钉	Clutch lever screw	1	
42	13-60153320-01	离合器杆螺母	Clutch lever nut SM15/64×28 H=3.3	2	
43	1300-08-43	离合器杆螺钉	Clutch lever screw	1	
44	1300-08-44	剪线电磁铁电线保护套	Protect bushing	1	
45	1300-08-45	电磁铁连杆轴位螺钉	Stud screw for mes cam	1	
46	13-60623020-01	螺母	Nut SM3/16×32 H=3	1	
47	1300-08-47	离合器杆底座	Base plate	1	
48	12-60501422-01	离合器杆底座螺钉	Base plate screw M5 L=14	3	
49	22-05000000-08	弹簧垫片	Spring washer φ5	3	
50	21-05310100-02	平垫片	Washer φ5	3	
51	1300-08-51	电磁铁连杆	Solenoid connecting link	1	
52	1300-08-52	电磁铁连杆销	Solenoid pin	1	
53	11-40110825-01	电磁铁连杆销螺钉	Solenoid pin screw SM11/64×40 L=8	1	
54	11-80110510-01	电磁铁连杆销紧固螺钉	Solenoid pin tighten screw SM11/64×40 L=5	1	
55	14-60504020-01	螺母	Nut M5 H=4	1	
56	1300-08-56	剪线电磁铁组件	Thread trimming solenoid ASM.	1	
57	1300-08-57	剪线电磁铁安装架	Base for solenoid connecting link	1	
58	22-06000000-08	弹簧垫片	Spring washer φ6	2	
59	11-40151225-01	剪线电磁铁紧固螺钉	Screw SM15/64×28 L=12	2	



9. 倒缝部件 Automatic Reverse Feed Components For 0311-7D2-Y and 0611-7D2-Y

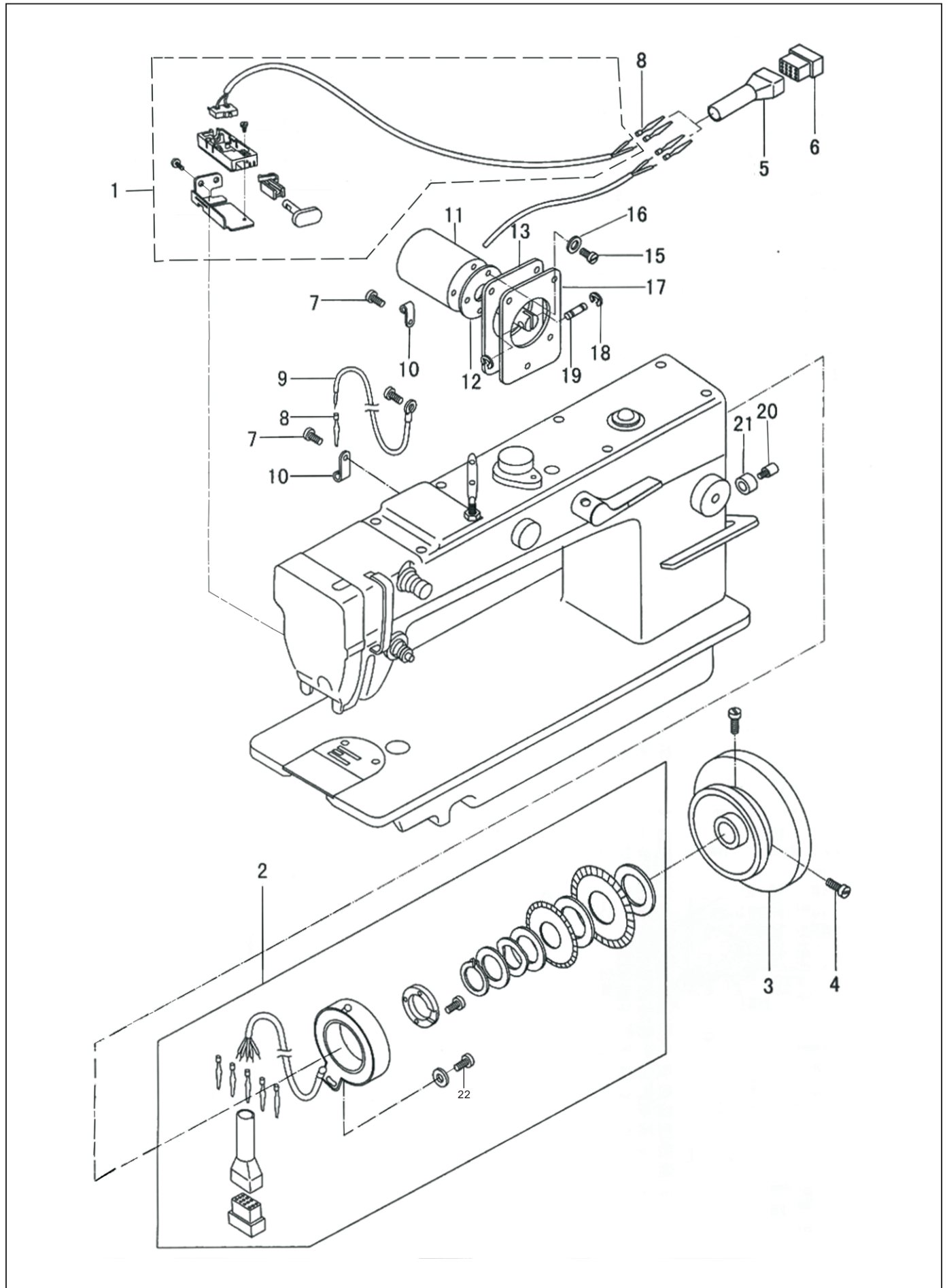

## 9. 倒缝部件 Automatic Reverse Feed Components For 0311-7D2-Y and 0611-7D2-Y

序号 NO.	图号 REF NO.	名称	DESCRIPTION	数量 AMT	备注 NOTE
1	1271-10-02	倒送料转换器组件	Reverse feed switch ASM	1	
2	1300-09-22	检测器组件	Dectector ASM	1	
3	1300-09-23	主动轮	Wheels	1	
4	11-80151550-01	主动轮螺钉	Wheels screw SM15/64×28 L=15	2	
5	158-09-47	插头套	Plug cover	1	
6	158-09-46	线罩	Nylon tie-in	1	
7	11-40110625-01	线夹螺钉	Screw SM11/64×40 L=6	2	
8	158-09-48-1	插头接头	Plug	5	
9	158-09-48	地线组件	Ground connection ASM.	1	
10	124-11-37	线夹	Cord holder	2	
11	1300-09-11	倒送料电磁铁组件	Automatic reverse feed magnetic ASM	1	
12	1300-09-12	倒送料电磁铁垫圈	Automatic reverse feed magnetic washer	1	
13	1300-01-10	后盖板	Side palte	1	
15	11-40111025-01	电磁铁螺钉	Screw SM11/64×40 L=9.4	4	
16	21-05010110-01	电磁铁螺钉垫圈	Washer φ5	4	
17	1300-01-11	后盖板垫圈	Side palte washer	1	
18	24-04000000-08	E型挡圈	E-ring	2	
19	1300-09-19	电磁铁销	Magnetic pin	1	
20	1300-09-20	支撑杆	Pin	1	
21	1300-09-21	操纵杆限位圈	Upper stopper rubber for reverse lever	1	
22	12-40501025-01	检测器固定螺钉	Screw	2	

# 10. 润滑部件 Oil Lubrication Components

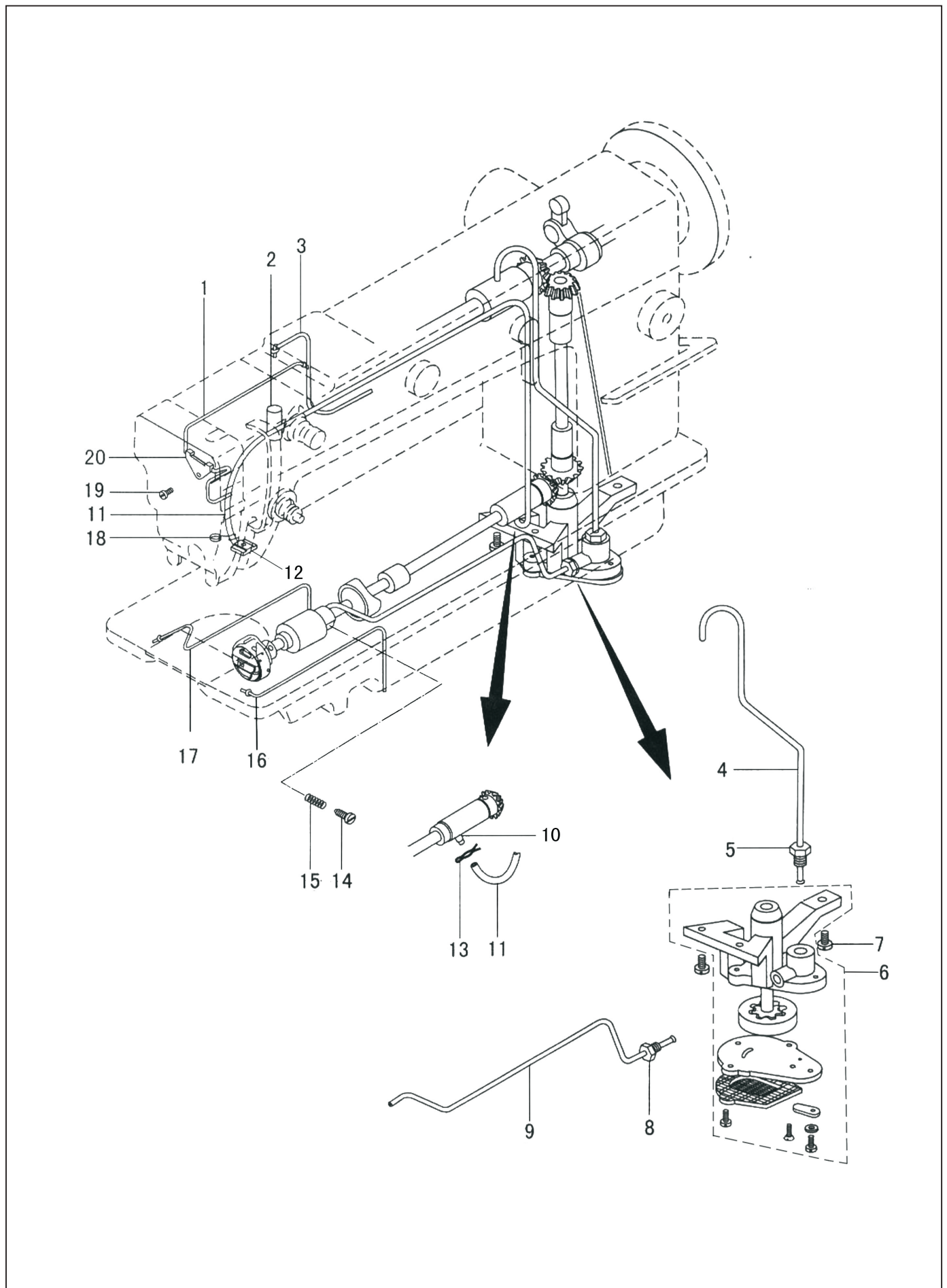

## 10. 润滑部件 Oil Lubrication Components

序号 NO.	图号 REF NO.	名称	DESCRIPTION	数量 AMT	备注 NOTE
1	43-10250000-00	油线	Oil wick $\phi$ 2.5 L=500	0.5	
2	132-10-40	羊毛毡	Oil felt	1	
3	43-10250000-00	油线	Oil wick $\phi$ 2.5 L=250	0.25	
4	1300-10-04	上轴油管组件	Oil tube ASM for arm shaft	1	
5	114-08-13-02	上轴油管接头	Oil tube joint for arm shaft	(1)	
6	120-07-01	油泵体组件	Oil pump assy	1	
7	11-70111320-01	油泵体螺钉	Screw SM11/64 $\times$ 40 L=13	3	
8	120-07-09-02	下轴油管接头	Oil tube joint for hook driving shaft	(1)	
9	1300-10-18	下轴油管组件	Oil tube ASM for hook driving shaft	1	
10	120-02-63	回油管接头	Oil returnpipe joint	1	
11	42-05003000-00	回油管	Oil returnpipe $\phi$ 5 $\times$ $\phi$ 3 L=700	0.7	
12	120-07-07	回油管滤油毡	Felt pouch	1	
13	120-07-13	回油管夹	Holder	1	
14	1300-10-14	油量调节螺钉	Screw	1	
15	113-06-21	油量调节弹簧	Oil adjusting spring	1	
16	43-10300000-00	油线	Oil wick $\phi$ 2.5 $\phi$ 3l = 250	0.25	
17	43-10300000-00	油线	Oil wick $\phi$ 2.5 $\phi$ 3 L =300	0.3	
18	120-07-08	回油管弹簧夹	Pipe hold	1	
19	11-40090625-01	油线固定架螺钉	Screw SM9/64 $\times$ 40 L=6	1	
20	1300-10-28	油线固定架	Oil thread bracket	1	

# 11. 附件 Accessories

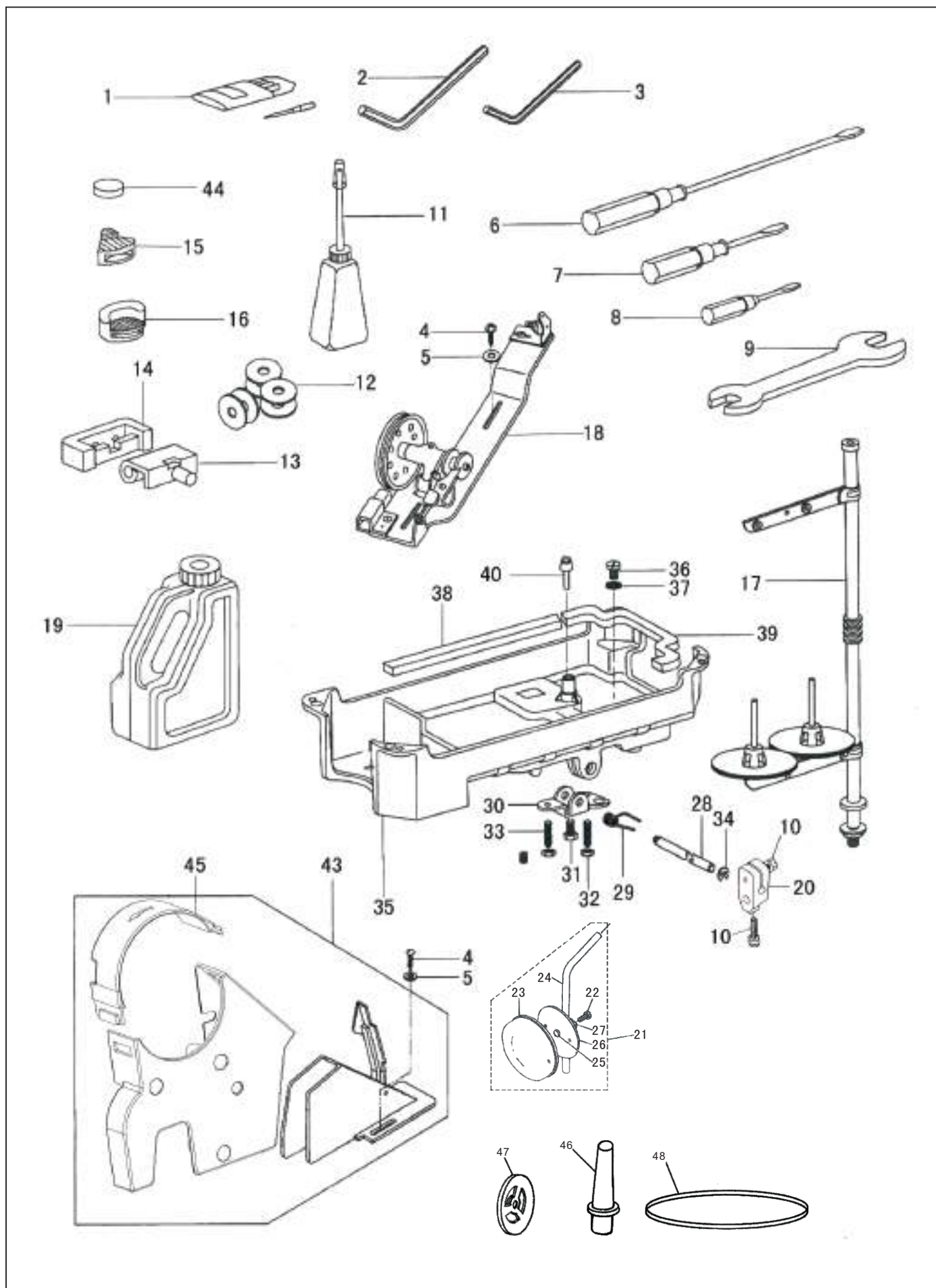

## 11. 附件 Accessories

序号 NO.	图号 REF NO.	名称	DESCRIPTION	数量 AMT	备注 NOTE
1	1300-02-07	机针 DP×17 #23	Needle DP x 17 23#	3	
2	301-20-26	内六角扳手 (3)	Hexagon wrench(s3)	1	
3	301-20-13	内六角扳手 (2)	Hexagon wrench(s2)	1	
4	101-12-08	木螺钉	Screw	2	配在绕线器组件里
5	21-04212090-02	木螺钉垫片	Screw washer	2	配在绕线器组件里
6	101-12-15	一字槽开刀 (大)	Screw driving(long)	1	
7	101-12-16	一字槽开刀 (中)	Screw driving(middle)	1	
8	101-12-17	一字槽开刀 (小)	Screw driving(short)	1	
9	109-13-01	双头扳手	Double-head wrench	1	
10	12-90801423-02	螺钉	Set screw M6 L=24	2	
11	120-09-06	小油壶	Oiler(small)	1	
12	120-02-72	梭心	Bobbin	2	0311/0611专用
	1222-05-03	梭心 (铝)	Bobbin(aluminum)	2	0311/0611不用
13	101-12-01	机壳铰链	Hinge of machine head	2	
14	120-09-02	机壳铰链套	Rubber socket for hinge	2	
15	120-09-04	机头防震垫块 (大)	Rubber cushion(big)	2	
16	120-09-05	机头防震垫块 (小)	Rubber cushion(small)	2	
17	101-11-01	线架组件	Thread stand ASM	1	
18	101.10-01-00	绕线器组件	Bobbin winder ASM	1	
19	101-12-21	油箱	Oil container	1	
20	101-09-10	膝提操纵杆接头	Knee press rod bearing bracket	1	
21	101.09-15-00	操纵杆组件	Knee lifter plate rod ASM.	1	
22	11-90151520-01	操纵杆夹头螺钉	Screw SM15/64×28 L=15	(1)	
23	101.09-20	操纵板软垫	Knee press plate ASM.	(1)	
24	101.09-15	操纵杆	Knee lifter plate rod	(1)	
25	101.09-18	操纵杆垫块	Rubber	(1)	
26	101.09-19	操纵板	Knee press plate	(1)	
27	101.09-17	操纵杆夹头	Lnee press plate holder	(1)	
28	1300-11-28	膝控铰链轴	Hinge pin for knee lifter	1	
29	426-11-08	膝控复位簧	Return spring for knee lifter	1	
30	1300.11-30	膝控限位架	Knee lifter stop bracket	1	
31	12-90601633-02	膝控铰链轴螺钉	Set screw M=6 L=15	1	
32	14-60603320-02	限位调节螺母	Lock nut M6	2	
33	12-50603050-02	限位调节螺钉	Adjusting screw M6 x 30	2	
34	24-09000000-08	E型挡圈	E-ring	2	
35	1300-11-35	油盘	Oil reservoir	1	
36	12-40801025-01	放油螺钉	Oil brain screw M8 L=10	1	
37	120-08-03	放油螺钉垫圈	Oil brain screw washer	1	
38	1300-11-41	油盘垫 (大)	Gasket for oil reser voir(big)	1	
39	1300-11-39	油盘垫 (小)	Gasket for oil reser voir(small)	1	
40	101.09-02	膝控提升顶杆	Knee lifter stop bracket	1	
43	1300-11-49	皮带罩组件	Belt ASM.	1	0311D/0611D不用
44	120-09-07	小磁块	Magnet	1	
45	1300-11-49-02	皮带上罩	Belt cover(upper)	(1)	0311D/0611D不用
46	101-12-19	机头支柱	Machine restin	1	
47	120.09-14	电机带轮φ60	Wheel for motor	1	
48	114.12-15	皮带 M42	Belt M42	1	

# 索引 Index

序号 NO.	图号 REF NO.	数量 AMT.
4/11	101-01-02	1
1/9	101-01-14	2
1/32	101-01-17	1
3/21	101-02-06	2
4/1	101-02-06	1
5/9	101-02-06	1
6/20	101-02-06	1
2/44	101-02-11	1
2/47	101-02-13	(1)
2/26	101-02-33	1
3/32	101-05-08	1
3/33	101-05-09	1
3/41	101-05-16	1
2/42	101-05-18	1
2/41	101-05-20	1
2/36	101-05-25	1
2/35	101-05-26	1
11/40	101-09-02	1
11/20	101-09-10	1
11/17	101-11-01	1
11/13	101-12-01	2
11/4	101-12-08	4
11/6	101-12-15	1
11/7	101-12-16	1
11/8	101-12-17	1
11/19	101-12-21	1
4/26	101-07-06	1
11/9	109-13-01	1
10/15	113-06-21	1
10/14	113-06-22	1
1/14	114-01-20	1
10/5	114-08-13-02	(1)
1/33	120-01-06	1
1/34	120-01-07	1
1/29	120-01-18	1
1/24	120-01-20	1
1/51	120-01-25	1
1/26	120-01-27	4
1/6	120-01-30	4
1/12	120-01-30	1
1/49	120-01-36	1
2/3	120-02-14	1
2/2	120-02-15	1
1/1	120-02-16	4
2/1	120-02-16	1
2/6	120-02-20	1
2/14	120-02-23	1
2/13	120-02-25	1
3/42	120-02-62	1
10/10	120-02-63	1
3/45	120-02-64	1
3/46	120-02-65	1
3/47	120-02-66	1
3/28	120-02-69	1
3/26	120-02-72	1
11/12	120-02-72	4
4/38	120-03-21	1
4/46	120-03-27	1
3/3	120-04-01	1
3/8	120-04-03	1

序号 NO.	图号 REF NO.	数量 AMT.
3/2	120-04-06	1
3/54	120-04-24	1
7/24	120-05-06	1
7/8	120-05-08	1
7/12	120-05-14	1
7/11	120-05-16	1
7/7	120-05-21	1
6/35	120-06-01	1
6/39	120-06-19	1
5/19	120-06-28	1
6/22	120-06-28	2
6/45	120-06-46	2
6/47	120-06-47	1
10/6	120-07-01	1
10/12	120-07-07	1
10/8	120-07-09-02	(1)
10/13	120-07-13	1
11/37	120-08-03	1
11/30	120-08-08	1
11/27	120-08-13	1
11/25	120-08-16	1
11/24	120-08-17	1
11/26	120-08-19	1
11/14	120-09-02	2
11/15	120-09-04	2
11/16	120-09-05	2
11/11	120-09-06	1
11/44	120-09-07	1
11/18	120-10-01	1
7/26	122-05-27	1
6/48	122-06-45	1
9/10	124-11-37	2
8/38	124-11-37	1
10/2	132-10-40	1
9/6	158-09-46	1
9/5	158-09-47	1
9/9	158-09-48	1
9/8	158-09-48-1	5
1/2	193-01-42	1
8/32	279-04-37	1
11/3	301-20-13	1
11/2	301-20-26	1
1/27	409-11-01	1
11/29	426-11-08	1
6/53	120-02-65	2
1/13	11-00090620-02	1
1/28	11-00090620-02	2
1/31	11-00110520-01	2
7/1	11-00110520-01	1
3/40	11-00110520-01	2
3/10	11-00121520-01	1
8/2	11-10090620-01	1
8/12	11-10090720-01	3
8/9	11-10110622-01	2
1/43	11-20110920-02	2
7/39	11-40090525-01	1
10/19	11-40090625-01	1
8/39	11-40090625-01	1
5/21	11-40090725-01	2
3/1	11-40110625-01	1

序号 NO.	图号 REF NO.	数量 AMT.
9/7	11-40110625-01	2
1/35	11-40110625-01	1
3/53	11-40110625-01	1
1/3	11-40110825-01	9
4/10	11-40110825-01	6
8/6	11-40110825-01	1
4/45	11-40110825-01	1
8/53	11-40110825-01	1
6/38	11-40110825-01D	2
1/15	11-40111025-01	8
9/15	11-40111025-01	4
6/11	11-40111625-01	4
4/41	11-40121625-01	1
8/59	11-40151225-01	2
3/17	11-40151525-01	1
5/2	11-40151525-01	2
11/42	11-40151525-01	3
3/4	11-40621425-01	4
1/50	11-60060220-01	2
2/8	11-60080520-01	1
3/6	11-60080620-01	2
7/27	11-60091120-01	1
7/22	11-60110721-01	1
2/12	11-60110820-01	1
6/46	11-60111220-01	2
1/44	11-60112020-01	2
1/45	11-60113020-01	1
3/16	11-60150720-01	1
3/48	11-60151020-01	1
6/6	11-60151460-01	1
6/44	11-70090820-01	1
3/27	11-70111120-01	1
10/7	11-70111320-01	3
4/37	11-70121820-01	1
4/39	11-70121820-01	1
5/27	11-70151020-01	1
2/18	11-70221020-01	1
8/3	11-80080312-01	2
8/54	11-80110510-01	1
6/9	11-80110512-01	2
8/33	11-80110512-01	2
7/30	11-80110610-01	1
3/12	11-80110612-01	1
1/23	11-80110910-01	1
7/16	11-80150510-01	2
3/34	11-80150510-01	2
1/30	11-80150710-01	1
4/4	11-80150710-01	1
5/3	11-80150710-01	2
6/2	11-80150710-01	4
2/25	11-80150810-01	1
5/16	11-80150810-01	1
7/4	11-80150810-01	1
8/28	11-80150812-01	2
2/38	11-80150812-01	2
2/9	11-80151010-01	1
4/5	11-80151010-01	1
4/14	11-80151010-01	1
3/44	11-80151010-01	2
3/52	11-80151010-01	2

# 索引 Index

序号 NO.	图号 REF NO.	数量 AMT.
6/33	11-80151010-01	1
6/56	11-80151010-01	4
9/4	11-80151550-01	2
11/33	11-80153050-02	2
2/27	11-80160510-01	2
3/22	11-80160510-01	4
4/2	11-80160510-01	2
5/10	11-80160510-01	2
6/21	11-80160510-01	2
7/54	11-80160610-01	1
2/15	11-80160710-01	7
2/34	11-80160710-01	(8)
3/36	11-80161012-01	2
2/17	11-80181650-01	1
11/23	11-90150823-01	1
8/35	11-90621323-01	2
11/41	12-40401025-01	1
7/48	12-40401025-01	1
7/52	12-40401025-01	1
11/36	12-40801025-01	1
8/48	12-60501422-01	3
8/17	12-60601522-01	1
4/33	12-80400512-01	1
11/31	12-90601633-02	1
11/10	12-90801423-02	2
6/36	13-60093020-01	1
1/7	13-60113020-02	1
5/5	13-60114020-01	1
6/31	13-60153320-01	1
8/42	13-60153320-01	2
11/32	13-60153320-02	2
7/33	13-60153620-01	1
5/25	13-60163220-01	1
5/13	13-60184020-01	1
8/15	13-60623020-01	2
8/26	13-60623020-01	2
8/46	13-60623020-01	1
8/55	14-60504020-01	1
7/50	14-60504020-02	1
7/51	14-60504020-02	(1)
7/31	21-04210080-02	1
11/5	21-04212090-02	4
7/47	21-04508080-01	1
6/60	21-04608080-01	1
8/7	21-04808080-01	1
9/16	21-05010110-01	4
8/36	21-05010110-02	2
8/50	21-05010110-02	3
7/38	21-06106100-01	1
3/5	21-06113102-03	1
5/6	21-06113102-03	1
2/49	21-08010122-03	1
6/51	21-10130180-01	2
3/31	21-15020212-03	2
5/22	22-04000000-08	2
8/31	22-05000000-08	2
3/56	22-05000000-08	1
8/49	22-05000000-08	3
1/25	22-06000000-08	4
3/49	22-06000000-08	1

序号 NO.	图号 REF NO.	数量 AMT.
8/58	22-06000000-08	2
4/16	24-04000000-08	1
9/18	24-04000000-08	2
7/45	24-05000000-08	1
7/53	24-05000000-08	2
6/24	24-06000000-08	2
4/29	24-07000000-09	1
7/43	24-08000000-08	1
11/34	24-09000000-08	1
6/14	25-10000000-08	1
3/24	25-15000000-08	2
2/28	25-20000000-08	1
2/48	31-03618000-09	(2)
7/19	31-04018000-09	1
4/43	31-05018000-09	1
4/30	31-09624000-09	1
5/11	31-10020000-09	1
2/33	32-14170300-09	1
10/11	42-05003000-00	0.7
10/1	43-10250000-00	0.5
10/3	43-10250000-00	0.25
2/10	43-10300000-00	0.25
10/16	43-10300000-00	0.25
10/17	43-10300000-00	0.3
1/36	44-00000001-00	1
3/29	1222-05-01	1
3/25	1222-05-02	1
3/26	1222-05-03	1
11/12	1222-05-03	4
9/1	1271-10-02	1
1/4	1300-01-04	1
1/5	1300-01-05	1
1/8	1300-01-08	1
9/13	1300-01-10	1
1/10	1300-01-10B	1
1/11	1300-01-11	1
9/17	1300-01-11	1
1/16	1300-01-16	1
1/17	1300-01-17	1
1/18	1300-01-18	2
1/19	1300-01-19	1
1/20	1300-01-20	1
1/21	1300-01-21	1
1/22	1300-01-22	1
1/37	1300-01-37	1
1/38	1300-01-38	1
1/39	1300-01-39	1
1/40	1300-01-40	1
1/41	1300-01-54	1
1/42	1300-01-55	1
1/46	1300-01-59	1
1/47	1300-01-60	1
1/47	1300-01-60B	1
1/48	1300-01-61	1
1/48	1300-01-61B	1
2/4	1300-02-04	1
2/5	1300-02-05	1
2/7	1300-02-07	1
11/1	1300-02-07	4
2/11	1300-02-11	1

序号 NO.	图号 REF NO.	数量 AMT.
2/16	1300-02-16	1
2/19	1300-02-19	1
2/20	1300-02-20	1
2/21	1300-02-21	1
2/22	1300-02-22	1
2/23	1300-02-23	1
2/24	1300-02-24	1
2/29	1300-02-29	1
2/30	1300-02-30	1
2/31	1300-02-31	1
2/32	1300-02-32	1
2/37	1300-02-37	1
2/39	1300-02-39	1
2/40	1300-02-40	1
2/43	1300-02-44	1
2/45	1300-02-46	1
2/46	1300-02-46-01	(1)
3/7	1300-03-07	1
3/9	1300-03-09	1
3/11	1300-03-11	1
3/13	1300-03-13	1
3/14	1300-03-14	1
3/15	1300-03-15	2
3/18	1300-03-18	1
3/19	1300-03-19	1
3/20	1300-03-20	1
3/23	1300-03-23	1
3/30	1300-03-30	1
3/35	1300-03-35	1
3/35	1300-03-35B	1
3/37	1300-03-37	1
3/38	1300-03-38	1
3/39	1300-03-39	1
3/43	1300-03-43	1
3/50	1300-03-50	1
3/51	1300-03-51	1
3/55	1300-03-55	1
5/4	1300-03-57	1
3/57	1300-03-57	2
4/6	1300-04-06	1
4/7	1300-04-07	1
4/8	1300-04-08	1
4/9	1300-04-09	2
4/12	1300-04-12	1
4/13	1300-04-13	1
4/15	1300-04-15	1
4/17	1300-04-17	1
4/18	1300-04-18	1
4/19	1300-04-19	2
4/21	1300-04-21	1
4/21	1300-04-21B	1
4/22	1300-04-22	1
4/24	1300-04-24	1
4/27	423.09-26	1
4/28	1300-04-28	1
4/31	1300-04-31	1
4/32	1300-04-32	1
4/34	1300-04-34	1
4/40	1300-04-40	1
4/42	1300-04-42	1



# 索引 Index

序号 NO.	图号 REF NO.	数量 AMT.
4/44	1300-04-44	1
4/44	1300-04-44B	1
4/47	1300-04-49	1
5/1	1300-05-01	1
5/7	1300-05-07	1
5/8	1300-05-08	1
5/12	1300-05-12	1
5/14	1300-05-14	1
5/15	1300-05-15	1
5/17	1300-05-17	1
5/18	1300-05-18	1
5/20	1300-05-20	1
5/23	1300-05-23	1
5/24	1300-05-24	1
5/26	1300-05-26	1
6/1	1300-06-01	1
6/3	1300-06-03	1
6/4	1300-06-04	1
6/5	1300-06-05	1
6/7	1300-06-07	1
6/8	1300-06-08	1
6/10	1300-06-10	1
6/12	1300-06-12	1
6/13	1300-06-13	1
6/15	1300-06-15	1
6/16	1300-06-16	1
6/17	1300-06-17	2
6/18	1300-06-18	1
6/19	1300-06-19	1
6/23	1300-06-23	1
6/25	1300-06-25	1
6/26	1300-06-26	2
6/27	1300-06-27	1
6/28	1300-06-28	1
6/29	1300-06-29	1
6/30	1300-06-30	1
6/32	1300-06-32	1
6/34	1300-06-34	1
6/54	1300-06-34	1
6/37	1300-06-37	1
6/40	1300-06-40	1
6/41	1300-06-41	1
6/42	1300-06-42	1
6/43	1300-06-43	1
6/48	1300-06-48	1
6/49	1300-06-49	1
4/3	1300-06-50	1
6/50	1300-06-50	1
6/52	1300-06-52	1
6/55	1300-06-55	1
6/57	1300-06-57	1
6/58	1300-06-58	1
6/59	1300-06-59	1
7/2	1300-07-02	1
7/3	1300-07-03	1
7/5	1300-07-05	1
7/6	1300-07-06	1
7/9	1300-07-09	1
7/10	1300-07-10	1
7/13	1300-07-13	1

序号 NO.	图号 REF NO.	数量 AMT.
7/14	1300-07-14	1
7/15	1300-07-15	2
7/17	1300-07-17	1
7/18	1300-07-18	1
7/20	1300-07-20	1
7/21	1300-07-21	1
7/37	1300-07-23	1
7/23	1300-07-23B	1
7/25	1300-07-25	1
7/55	1300-07-25B	1
7/26	1300-07-26	1
7/28	1300-07-28	1
7/29	1300-07-29	1
7/32	1300-07-32	1
7/34	1300-07-34	1
7/35	1300-07-35	1
7/36	1300-07-36	1
7/40	1300-07-40	1
7/41	1300-07-41	1
7/42	1300-07-42	1
7/44	1300-07-44	1
7/46	1300-07-46	1
7/49	1300-07-49	1
8/1	1300-08-01	1
8/5	1300-08-05	1
8/8	1300-08-08	1
8/10	1300-08-10	1
8/11	1300-08-11	1
8/13	1300-08-13	1
8/14	1300-08-14	2
8/16	1300-08-16	1
8/18	1300-08-18	1
8/19	1300-08-19	1
8/21	1300-08-21	1
8/22	1300-08-22	1
8/23	1300-08-23	1
8/24	1300-08-24	2
8/25	1300-08-25	2
8/27	1300-08-27	1
8/29	1300-08-29	1
8/30	1300-08-30	1
8/34	1300-08-34	1
8/37	1300-08-37	1
8/40	1300-08-40	1
8/41	1300-08-41	1
8/43	1300-08-43	1
8/44	1300-08-44	1
8/45	1300-08-45	1
8/47	1300-08-47	1
8/51	1300-08-51	1
8/52	1300-08-52	1
8/56	1300-08-56	1
8/57	1300-08-57	1
9/11	1300-09-11	1
9/12	1300-09-12	1
9/19	1300-09-19	1
9/20	1300-09-20	1
9/21	1300-09-21	1
9/2	1300-09-22	1
9/3	1300-09-23	1

序号 NO.	图号 REF NO.	数量 AMT.
10/4	1300-10-04	1
10/9	1300-10-18	1
10/18	1300-10-26	1
10/20	1300-10-28	1
11/28	1300-11-28	1
11/35	1300-11-35	1
11/39	1300-11-39	1
11/38	1300-11-41	1
11/43	1300-11-49	1
11/45	1300-11-51	(1)
1/42	1301-01-55	1
2/43	1301-02-44	1
3/7	1301-03-07	1
6/42	1301-06-42	1

## 获行业首家 全国质量奖

GEMSY GAINED CHINA QUALITY AWARD -- THE FIRST ONE TO WIN THIS AWARD IN SEWING MACHINE FIELD

全国服务热线：800-8576-822

SERVICE HOTLINE: 800-8576-822

**GEMSY 宝石**  **中国驰名商标**  **中国名牌产品**  **中国出口名牌**  **全国用户满意产品**         

地址：中国浙江省台州市东环大道638号 P.C: 318000

国内营销部：DOMESTIC SALES DEPARTMENT

TEL: 0576-88201401 88202041

FAX: 0576-88202667 88203211

Http://www.gemsy.com

ADD: NO.638 DONGHUAN ROAD, TAIZHOU, ZHEJIANG, CHINA

国际贸易部：INTERNATIONAL TRADE DEPARTMENT

TEL: 0086-576-88201479 88201471 88207338

FAX: 0086-576-88202667 88203211

E-mail : gemsy@gemsy.com