

GEMSY

使用说明书·零件样本
User Manual & Parts List

7720系列

超高速包缝机

Super High-Speed Overlock Machine

非常感谢您购买本公司的工业缝纫机。在使用缝纫机之前，请仔细阅读（为了您的安全使用）和使用说明书。

工业缝纫机的特性之一，是要在机针和旋梭等运动零部件附近进行操作，而这些零部件很容易引起受伤的危险，所以请在受过培训的人员或有熟练操作技术的人员的指导下，正确地使用本缝纫机。



为了您的安全使用

1. 安全使用的标记及其意义

本使用说明书及产品所使用的标记和图案记号是为了您的安全而正确地使用本产品，防止您及他人受到危害和损害。

表示方法及含义如下：

说明

 危险	如果忽视此标记而进行了错误的操作，必将导致人员死亡或重伤。
 注意	如果忽视此标记而进行了错误的操作，有可能会引起人员受伤及造成设备损坏。
 警告	如果忽视此标记而进行了错误的操作，将会引起人员重伤或死亡。

图案和符号



符号△表示“应注意事项”。
三角中的图案表示必须要注意的内容。
(如左图的符号表示“注意受伤”。)



符号⊘表示“禁止”。



符号●表示“必须”。
圆圈中的图案表示必须要做的内容。
(如左图的符号表示“必须接地”。)

Thank you very much for buying our sewing machine. Before using your new machine, please read the safety instructions below and the explanations given in the Operation Instruction.



With industrial sewing machines, it is normal to carry out work while positioned directly in front of moving parts such as the needle and thread take-up lever, and consequently there is always a danger of injury that can be caused by these parts. Follow the instructions from training personnel and instructors regarding safe and correct operation before operating the machine so that you will know how to use it correctly.

SAFETY INSTRUCTIONS

1. Safety indications and their meanings

This instruction manual and the indications and symbols that are used on the machine itself are provided in order to ensure safe operation of this machine and to prevent accidents and injury to yourself or other people. The meaning of these indications and symbols are given below.

Indications

	DANGER	The instructions which follow this term indicate situations where failure to follow the instructions will almost certainly result in death or severe injury.
	CAUTION	The instructions which follow this term indicate situations where failure to follow the instructions could cause injury when using the machine or physical damage to equipment and surroundings.
	CAUTION	The instructions which follow this term indicate situations where failure to follow the instructions will almost certainly result in death or severe injury.

Symbols



..... This symbol (\triangle) indicates something that you should be careful of. The picture inside the triangle indicates the nature of the caution that must be taken. (For example, the symbol at left means "beware of injury".)



..... This symbol (\otimes) indicates something that you must not do.



..... This symbol (\bullet) indicates something that you must do. The picture inside the circle indicates the nature of the thing that must be done. (For example, the symbol at left means "you must make the ground connection".)

2. 安全注意事项

危险



打开控制箱盖时，必须先关闭电源开关并将电源插头从插座上拔下，至少等待5分钟后，再打开控制箱盖。触摸带有高电压的区域将会造成人员伤亡。



请勿将手放入皮带开口处，否则手可能会将被卷入皮带中造成重伤。

注意

使用环境



应避免在强电气干扰源(如高频焊机)的附近使用缝纫机。
强电气干扰源可能会影响缝纫机的正确操作。



缝纫机的最佳工作环境是相对湿度在45%-85%的范围内，干燥或潮湿的环境均会影响缝纫机的正确操作。



电源电压的波动应该在额定电压的±10%以内的环境下使用。
电压大幅度的波动会影响缝纫机的正确操作。



使用时应避免暴露于直射的阳光下。
直射的阳光会影响缝纫机的正确操作。



电源容量应大于缝纫机的消耗能量。电源容量不足会影响缝纫机的正确操作。



万一发生雷电暴风雨时，关闭电源开关，并将电源插头从插座上拔下。雷电可能会影响缝纫机的正确操作。



环境温度应在5°C-35°C的范围内使用。
低温或高温会影响缝纫机的正确操作。

安装



请让受过培训的技术人员来安装缝纫机。



固定电缆时，不要过度弯曲电缆或用卡钉固定得过紧，会引起火灾或触电的危险。



请委托购买商店或电气专业人员进行电气配线。



如果使用带小脚轮的工作台，则应该固定小脚轮，使其不能移动。



缝纫机重约40公斤，安装工作必须由两人以上来完成。



缝纫机头倒下或竖起时，请用双手进行操作。单手操作时因缝纫机的重量万一滑落易导致受伤。



在安装完成前，请不要连接电源，如果误按启动开关，缝纫机动作会导致受伤。



使用润滑油或黄油时，务必戴好保护眼镜和保护手套等，以防润滑油落入眼中或沾在皮肤上，这是引起发炎的原因。
另外，润滑油或黄油不能饮用，否则会引起呕吐和腹泻。
将油放在小孩拿不到的地方。



请在切断电源后，再拔掉电源插头。不然易成为控制箱发生故障的原因。



必须接地。接驳地线不牢固，是造成触电或误动作的原因。

2. Notes on safety

DANGER



Wait at least 5 minutes after turning off the power switch and disconnecting the power cord from the wall outlet before opening the face plate of the control box. Touching areas where high voltages are present can result in severe injury.



Please do not put hand in belt openings, or hand may be involved into the belt will be seriously injured.

CAUTION

Environmental requirements



Use the sewing machine in an area which is free from sources of strong electrical noise such as high-frequency welders. Sources of strong electrical noise may cause problems with correct operation.



Any fluctuations in the power supply voltages should be within $\pm 10\%$ of the rated voltage for the machine. Voltage fluctuations which are greater than this may cause problems with correct operation.



The power supply capacity should be greater than the requirements for the sewing machine's electrical consumption. Insufficient power supply capacity may cause problems with correct operation.



The ambient temperature should be within the range of 5°C to 35°C during use. Temperatures which are lower or higher than this may cause problems with correct operation.



The relative humidity should be within the range of 45% to 85% during use, and no dew formation should occur in any devices. Excessively dry or humid environments and dew formation may cause problems with correct operation.



Avoid exposure to direct sunlight during use. Exposure to direct sunlight may cause problems with correct operation.



In the event of an electrical storm, turn off the power and disconnect the power cord from the wall outlet. Lightning may cause problems with correct operation.

Installation



Machine installation should only be carried out by a qualified technician.



Contact your dealer or a qualified electrician for any electrical work that may need to be done.



The sewing machine weighs approximately 40kg. The installation should be carried out by two or more people.



Don't connect the power cord until installation is complete, otherwise the machine may operate if the foot switch is depressed by mistake, which could result in injury.



Be sure to connect the ground. If the ground connection is not secure, you run a high risk of receiving a serious electric shock, and problems with correct operation may also occur.



Install the safety covers to the machine head and motor.



Hold the machine head with both hands when tilting it back or returning it to its original position. Furthermore, after tilting back the machine head, do not push the face plate side or the pulley side from above, as this could cause the machine head to topple over, which may result in personal injury or damage to the machine.



All cords should be secured at least 25mm away from any moving parts. Furthermore, do not excessively bend the cords or secure them too firmly with staples, otherwise there is the danger that fire or electric shocks could occur.



If using a work table which has casters, the casters should be secured in such a way so that they cannot move.



Be sure to wear protective goggles and gloves when handling the lubricating oil and grease, so that they don't get into your eyes or onto your skin, otherwise inflammation can result. Furthermore, do not drink the oil or eat the grease under any circumstances, as they can cause vomiting and diarrhoea. Keep the oil out of the reach children.

2. 安全注意事项

注意

缝纫



本缝纫机仅限于接受过安全操作培训的人员使用。



为了安全起见，在使用本缝纫机之前，请安装保护装置。如果未安装这些安全装置就使用缝纫机，会造成人身伤害及缝纫机损坏。



本缝纫机不能用于除缝纫以外的任何其他用途。



缝纫过程中不要触摸任何活动部件或将物件靠在运动部件上，因为这会导致受伤或缝纫机损坏。



发生下列情况时，请切断电源。否则误按动启动开关，缝纫机动作会导致受伤。

- 机针穿线时
- 更换机针或梭芯时
- 缝纫机不使用，或人离开缝纫机时



如果缝纫机操作中发生误动作，或者听到异常的噪声或闻到异常的气味，应立即切断电源。然后与购买商店或受过培训的技术人员联系。



如果使用带小脚轮的工作台，则应该固定小脚轮，使其不能移动。



如果缝纫机出现故障时，请与购买商店或受过培训的技术人员联系。

清洁



在开始清洁作业前，请切断电源。如果误踩了脚开关，缝纫机动作会导致人员受伤。



使用润滑油或黄油时，务必戴好保护眼镜和保护手套等，以防润滑油落入眼中或沾在皮肤上，这是引起发炎的原因，另外，润滑油或黄油不能饮用，否则会引起呕吐和腹泻。
将油放在小孩拿不到的地方。

2. Notes on safety

CAUTION

Sewing



This sewing machine should only be used by operators who have received the necessary training in safe use beforehand.



If using a work table which has casters, the casters should be secured in such a way so that they cannot move.



The sewing machine should not be used for any applications other than sewing.



Attach all safety devices before using the sewing machine. If the machine is used without these devices attached, injury may result.



Be sure to wear protective goggles when using the machine.
If goggles are not worn, there is the danger that if a needle breaks, parts of the broken needle may enter your eyes and injury may result.



Do not touch any of the moving parts or press any objects against the machine while sewing as this may result in personal injury or damage to the machine.



Turn off the power switch at the following times, otherwise the machine may operate if the foot switch is depressed by mistake, which could result in injury.

- When threading the needle
- When replacing the needle and bobbin
- When not using the machine and when leaving the machine unattended



If an error occurs in machine operation, or if abnormal noises or smells are noticed, immediately turn off the power switch. Then contact your nearest dealer or a qualified technician.



If the machine develops a problem, contact your nearest dealer or a qualified technician.

Cleaning



Turn off the power switch before carrying out cleaning, otherwise the machine may operate if the foot switch is depressed by mistake, which could result in injury.



Be sure to wear protective goggles and gloves when handling the lubricating oil and grease, so that they do not get into your eyes or onto your skin, otherwise inflammation can result. Furthermore, do not drink the oil or eat the grease under any circumstances, as they can cause vomiting and diarrhoea. Keep the oil out of the reach of children.

目录 CONTENTS

1. 在使用之前 Before Operating	1
1-1. 台板加工图	1
Schematic Diagram Of The Machine Table	
1-2. 缝纫机的安装方法	2
Installing The Machine Head	
1-3. 缝纫机的旋转方向及转数	2
The Machine Speed And The Turning Direction	
1-4. 供油	3
Lubrication	
1-5. 手动供油	3
Manual Lubrication	
1-6. 给HR装置供油	3
Filling The HR Device With Silicon Oil	
1-7. 穿线的方法	4
Threading	
2. 试缝 Test Sewing	5
2-1. 压脚压力的调节	5
Adjusting The Presser Foot Pressure	
2-2. 差动比的调节	5
Adjusting The Dife Feed Ratio	
2-3. 针脚长度的调节	5
Adjusting The Stitch Length	
2-4. 线状态的调节	6
Adjusting The Thread Tension	
3. 使用中的保养 Maintenance During Use	7
3-1. 缝纫机的清扫	7
Cleaning The Machine	
3-2. 换针	7
Replacing The Machine	
3-3. 检查机油的循环	8
Checking The Oil Circulation	
3-4. 换机油	8
Replacing The Oil	
4. 常见故障和调整 Trouble Shooting	10
5. 零件样本 Partsbook	16

1. 在使用之前 Before Operating

1. 在使用之前 Before Operating

1-1. 台板加工图 Schematic Diagram Of The Machine Table

请参照下图进行台板的加工 Cut the table referring to the diagram

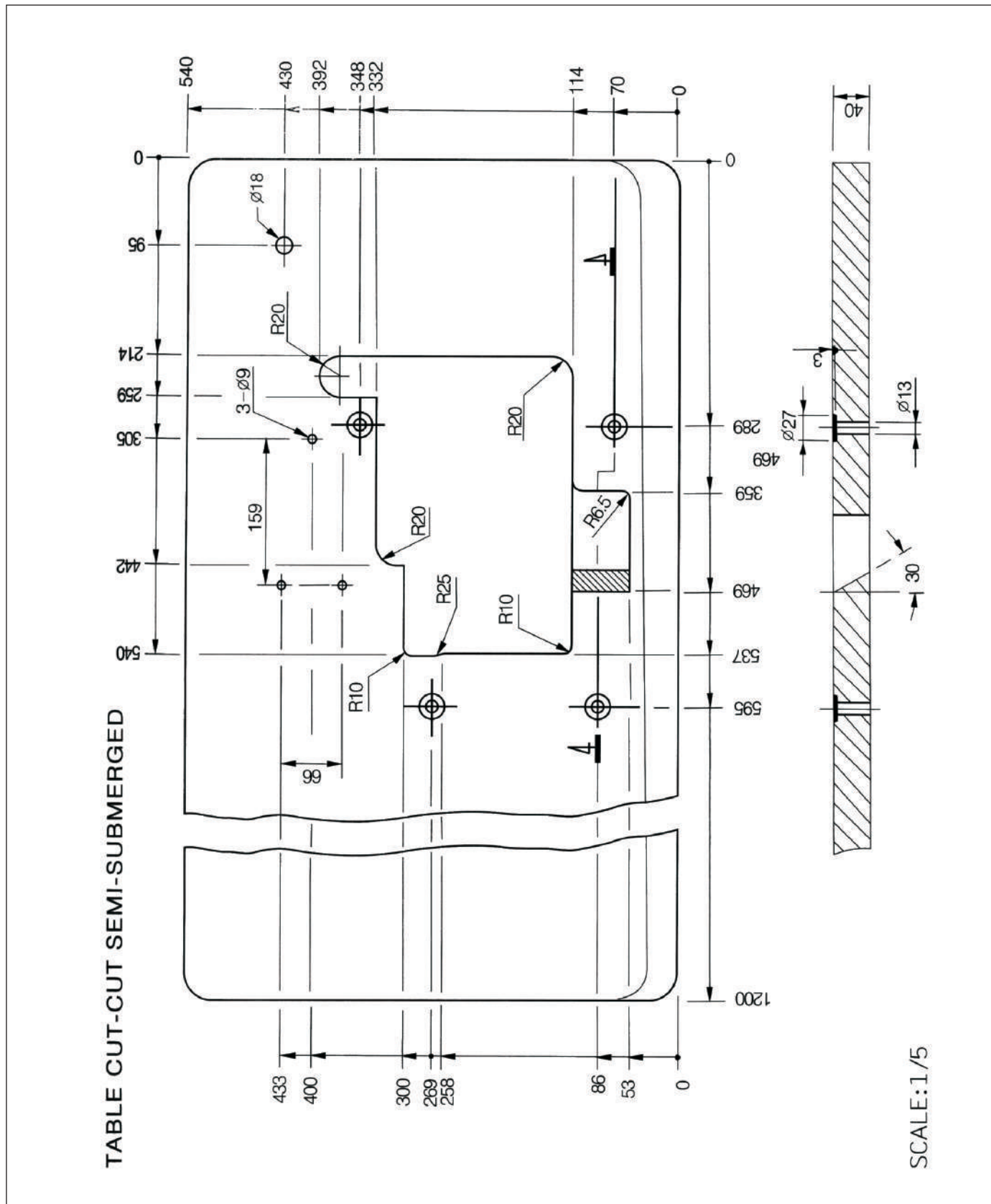

1. 在使用之前 Before Operating

1-2. 缝纫机的安装方法 Installing the machine head

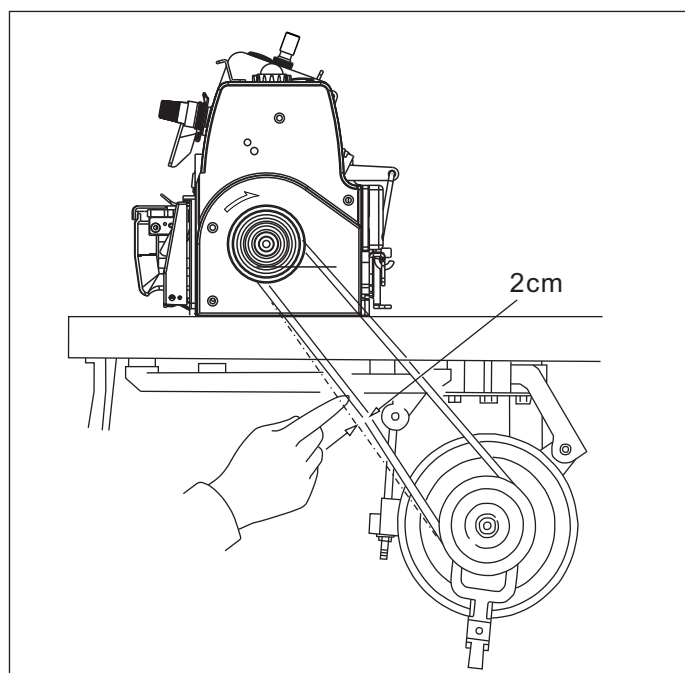

1. 将缝纫机装于台板之上，给缝纫机侧皮带轮和马达侧皮带轮装上三角胶带。
2. 将马达高度调整到用手指按压皮带中间时，约有2cm左右的松弛量为好。
3. 请装好皮带的护盖。

EN

1. Mount the machine head on the machine rest board.
2. Adjust the tension of the belt so that it can be about 2cm bent inward when you press the Middle of it. Adjust the height of the motor to do this.
3. Install the belt cover referring to the Figure

1-3. 缝纫机的旋转方向及转数 The machine speed and turning direction

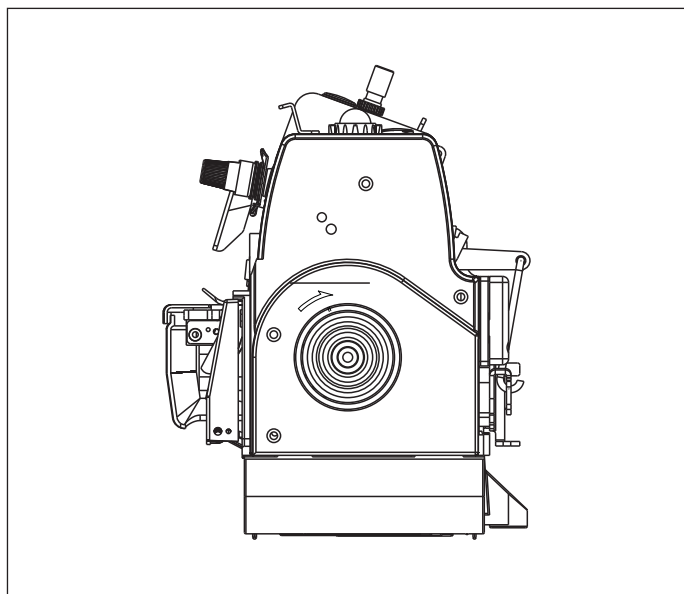

缝纫机的旋转方向，从皮带轮侧看是向右旋转的(即箭头方向)。

EN

The machine rotates clockwise when seen from the machine pulley side.

参照下表选用与所使用的缝纫机对应的转数。

Make sure your machine type and run it not exceeding the maximum speed as listed in the table.

缝纫机机型Machine type	最高旋转数(r. p. m) Max.speed
三线(Three thread)	6, 000
四线(Four thread)	6, 000
五线(Five thread)	5, 500
六线(Six thread)	5, 500
厚料(Heavy-weight material)	5, 500

1. 在使用之前 Before Operating

1-4. 加油 Lubrication

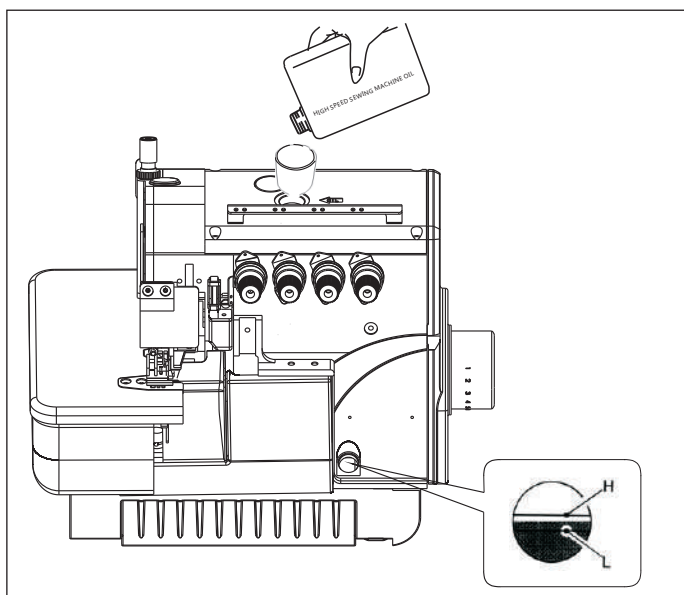

加油量是使油面处于H线与L线之间为好。当油面低于L线时，就要及时补充机油。

机油请使用本公司指定的用油：

（建议使用18#缝纫机油）

EN

After filling the oil pan, the oil surface should lie between (H) and (L) lines.

Add oil, when the oil surface reaches or goes below (L).

Note: Use our company recommended oil:

HIGH SPEED SEWING MACHINE OIL

(We suggest using Oil 18#)

1-5. 手动给油 Manual lubrication

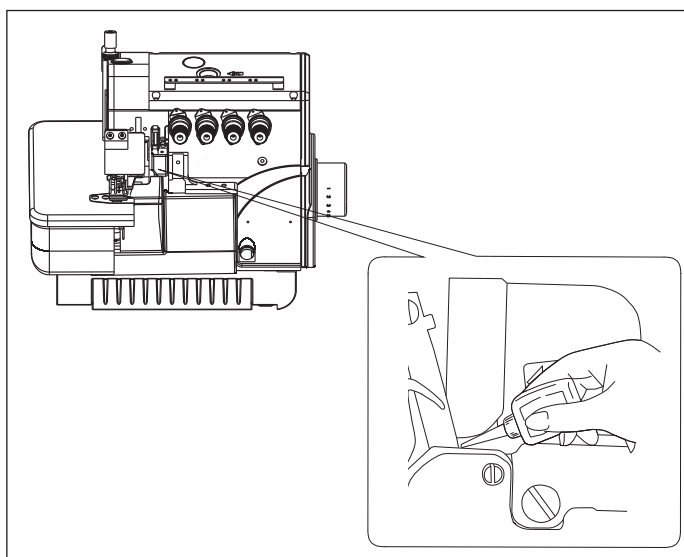

在缝纫机最初开始使用时，或停用一段时间重新开始使用时，请手动供给2—3滴油。

机油请使用本公司指定的用油：

HIGH SPEED SEWING MACHINE OIL.

EN

Apply 2 or 3 drops of oil by hand when the machine is used for the first time or has been left unused for some time.

Note: Use our company recommended oil:

HIGH SPEED SEWING MACHINE OIL

1-6. 给HR装置供油 Filling the HR device with silicon oil

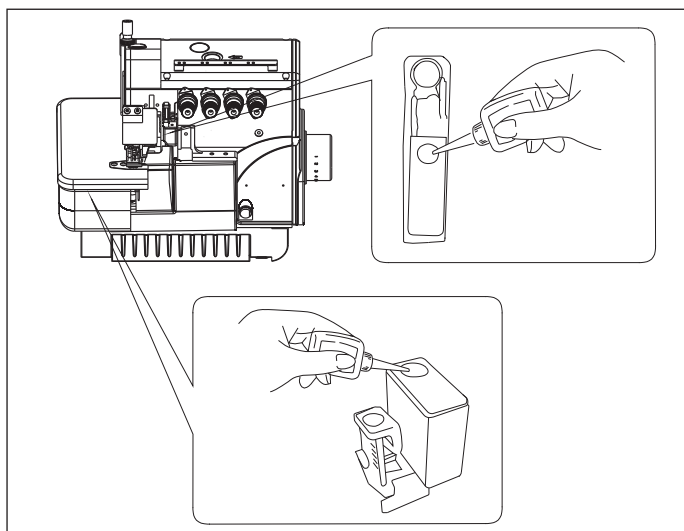

为了防止布纤维或线被切断，请尽早给HR装置供油。

注：关于购买硅油，请询问缝纫机代销店或与本公司营业所联系。

EN

Fill the HR device with oil before it is too low in order to prevent needle thread breakage and fabric damage.

Note: Use our company recommended silicon oil.

1. 在使用之前 Before Operating

1-7. 穿线的方法 Threading

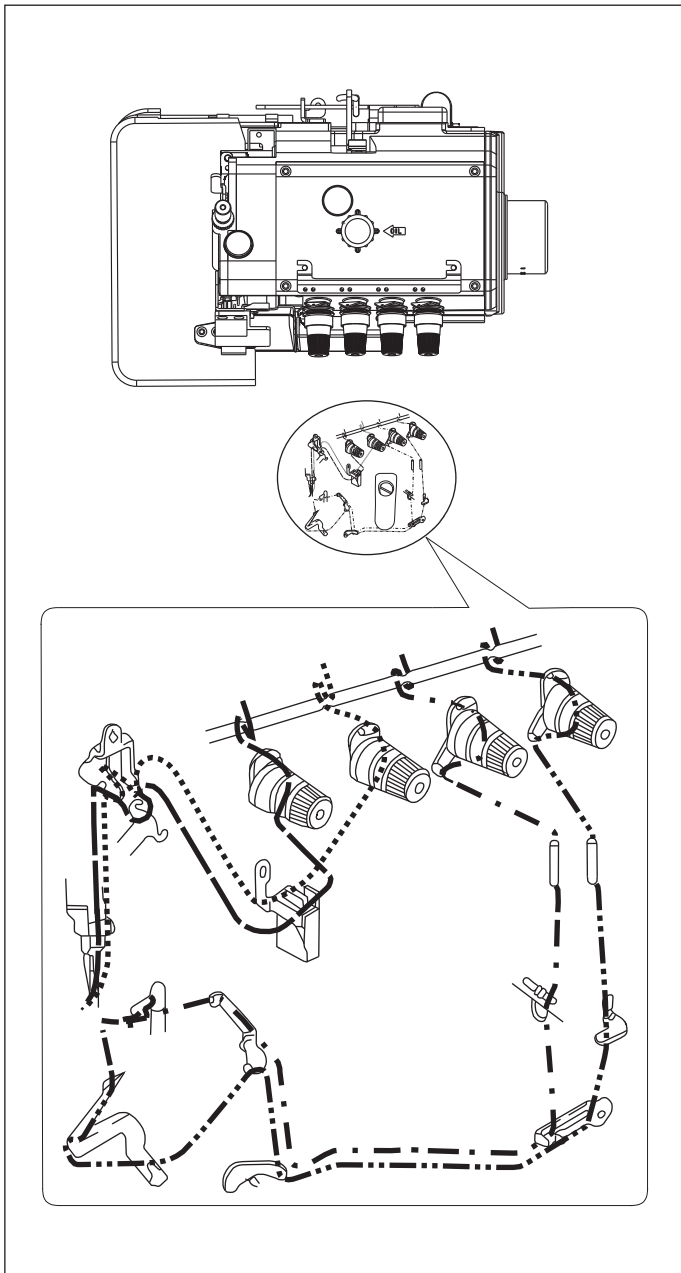

把机上原有的线与缝纫用线绑结在一起。

针线

将针线拉到针眼附近，剪掉结头再次穿好针线。

若机上原来没有线，请参照穿线图正确进行穿线。

弯针线

将弯针线上的接头直接拉出弯针孔后，再剪断接头。

EN

Knot the preset thread and the thread being used together to thread the machine.

Needle thread

Trim the knots off neatly before passing through the eye of the needle to rethread.

Be sure to thread the machine correctly by referring to the threading diagram.

Looper thread

Trim the knots off neatly after passing through the eye of the looper.

2. 试缝 Test Sewing

2-1. 压脚压力的调节 Adjusting the presser foot pressure

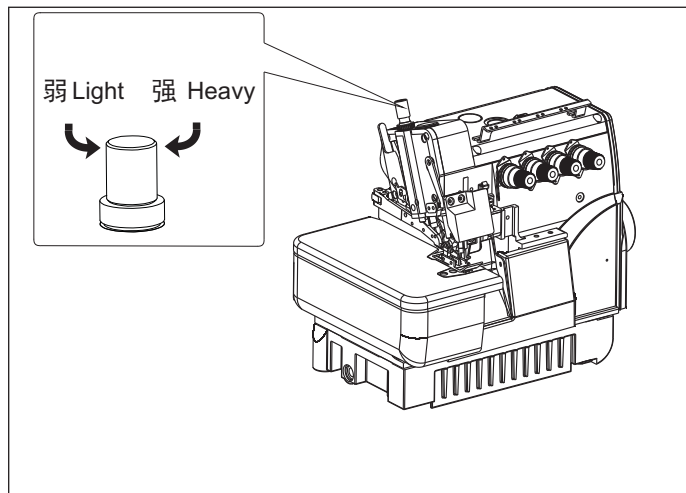

压脚压力的调节可旋转螺帽进行调节。在送布状态良好并能取得均匀针脚的范围內，尽可能使用较弱的压力为好。

EN

Turn adjusting screw to adjust the presser foot pressure. It should be as light as possible, yet be sufficient to obtain the proper stitch formation.

2-2. 差动比的调节 Adjusting the diff feed ratio

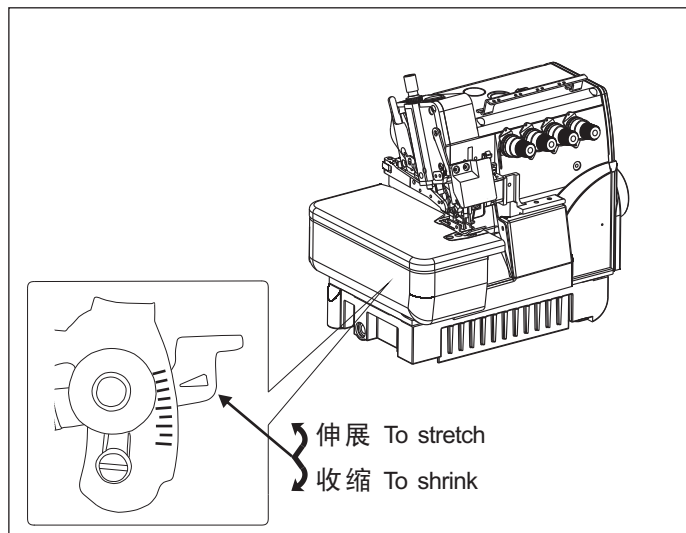

正确的差动比调节:先放松调节螺母，上下移动杠杆扳手位置，在调整好后再拧紧调节螺母。

EN

Loosen the nut and move the lever up and down to obtain the correct differential feed ratio. Tighten the nut after positioning the lever as desired.

2-3. 针脚长度的调节 Adjusting the stitch length

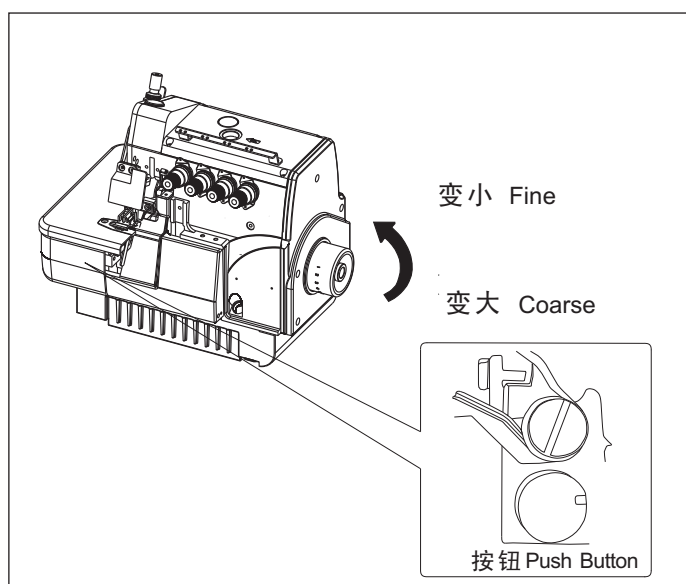

持续压下按钮并转动皮带轮使钮卡住，再转动皮带轮至所需之针距后放开按钮。

注：针脚长度的调节务必请在调节差动比之后进行。

EN

While pressing the push button, turn the handwheel to seek the position at which the push button goes further into the depth.

Then, keeping the push button pressed, turn the handwheel and set the desired scale to the aligning mark.

Note: Stitch length adjustment must only be made after the differential feed ratio has been changed.

2. 试缝 Test Sewing

2-4. 线状态的调节 Adjusting the thread tension

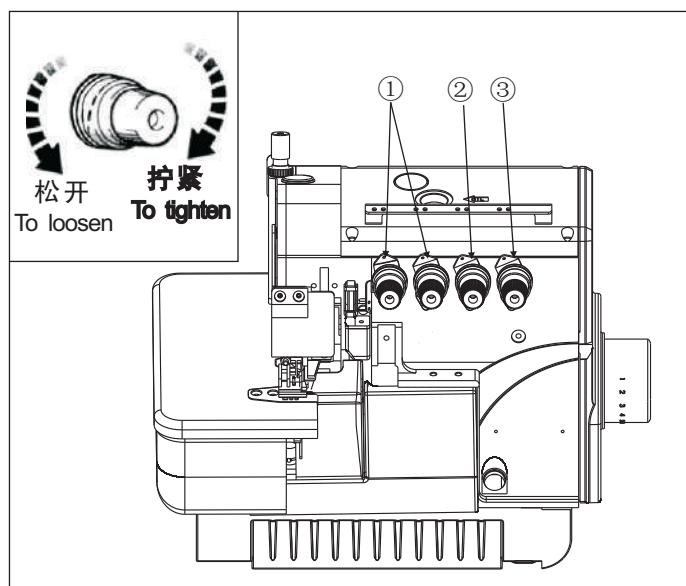

线张力状态的调节，针线调节夹线螺母①、上弯针线调节夹线螺母②、下弯针线调节夹线螺母③来进行调节。

EN

Make tension adjustments with the needle thread knob①, the upper looper knob②, and the lower looper knob③.

3. 使用中的保养 Maintenance during use

3-1. 缝纫机的清扫 Cleaning the machine

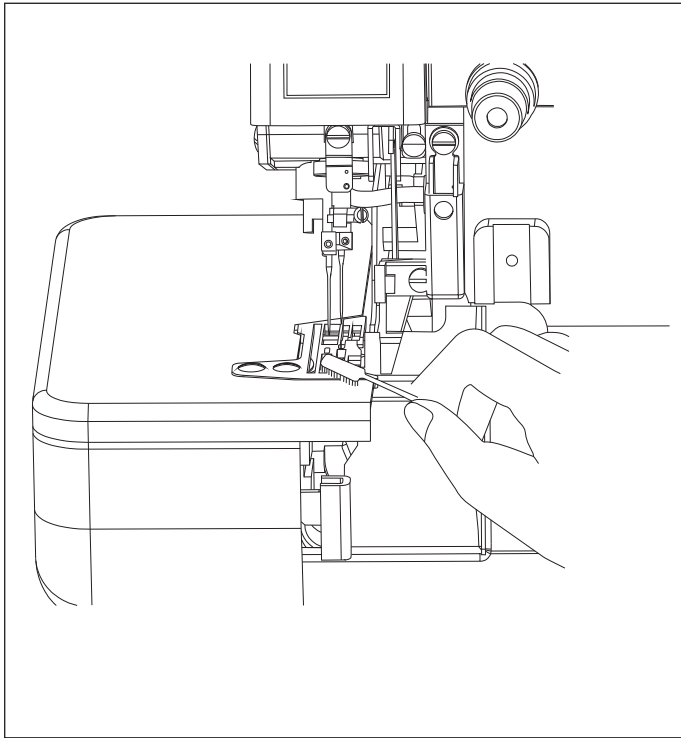

根据缝料的性质，定期清扫针板及送布牙上的灰尘。

EN

Please according to sewing material, to clean the dust of needle plate and feed dog in time.

3-2. 换针 Replacing the needle

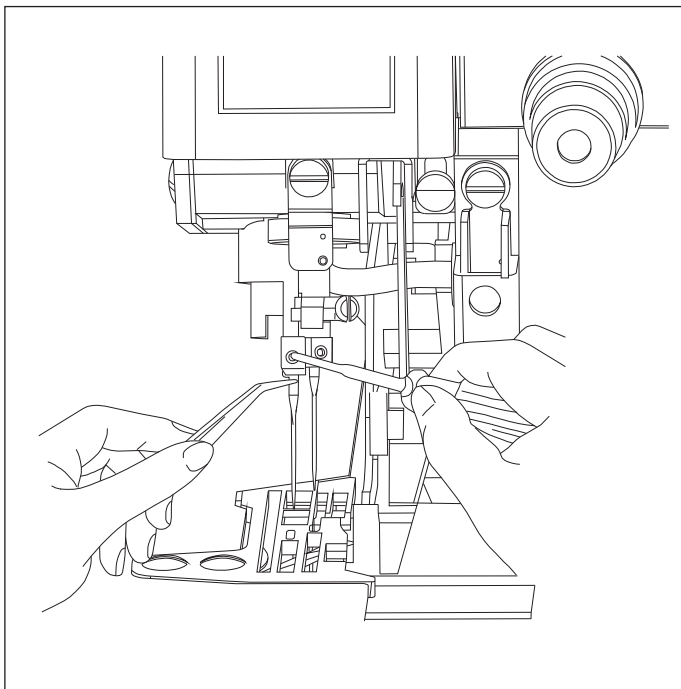

首先旋开螺丝并取下针，选择同型号机针，将针插至针夹孔最底端，并使针长凹槽面向自己，再固定螺丝。

注意：请不要把螺丝卸下来。

EN

Check the needle carefully to see that the scarf is turned to the rear of the machine.

Insert the needle to the proper depth and fasten securely.

Be sure to use the yellow-handled hex driver packaged in the accessory box.

Note: Do not remove the screw.

3. 使用中的保养 Maintenance during use

3-3. 检查机油的循环 Checking the oil circulation

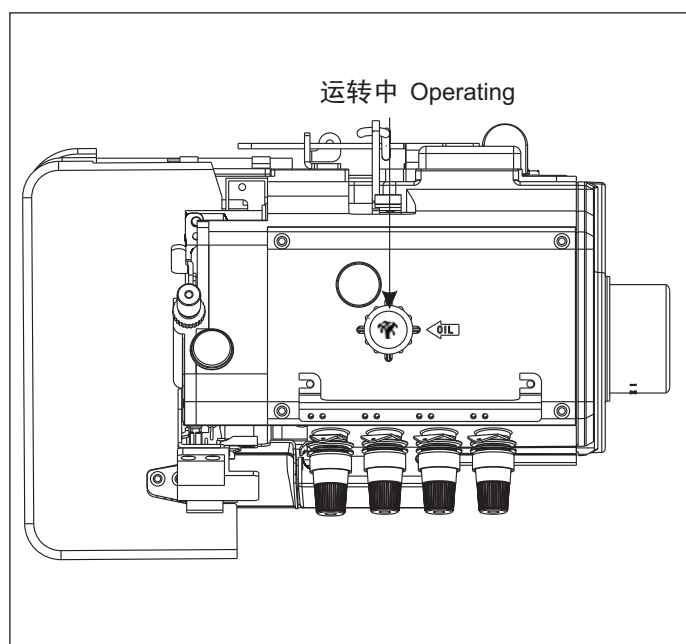

运转缝纫机，当转速达到2000转/分时油窗应有机油喷出。

EN

In running the machine, when the speed get 2000RPM, you can see the oil out of the oil window.

3-4. 换机油 Replacing the oil

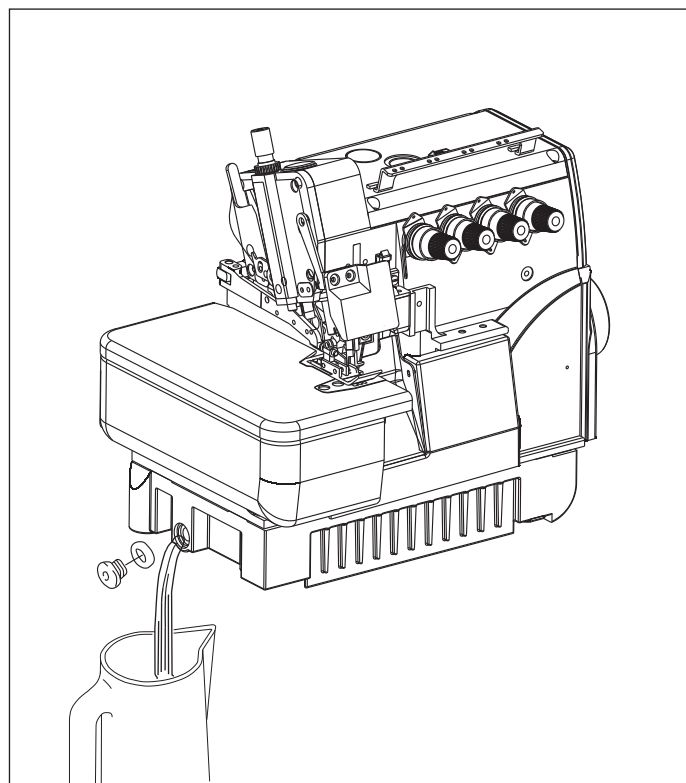

机油的更换，请在使用开始1个月后更换一次。然后，每6个月更换一次。

EN

Replace the oil one month after the first use and every six months thereafter.

3. 使用中的保养 **Maintenance during use**

标准使用的缝纫针 **Standard needle**

机种 Model	针号 Size	机种 Model	针号 Size
7723	11#	7725H	18#
7724	11#	7725XH	18#
7725	14#	7726	14#

针号对照表 **Comparison table of equivalent sizes**

日本针号 Japanese size	#	9	11	14	16	18	21
德国针号 Metric size	Nm	65	75	90	100	110	130

4. 常见故障和调整

4. 常见故障和调整

在修理、服务之前请先按下面要点检查；

按照下面方法处理仍不能排除故障时，请及时与缝纫机经销商联系。

故障现象	产生原因	调整方法
包缝时机针线松	①机针线夹板压线力过松	旋紧机针线夹线螺母
	②机针线出线量过多	调整机针挑线杆使机针出线量减少
	③下弯针夹线板压力过紧,致使机针线被拉下去	旋松下弯针线夹线螺母或调节下弯针挑线杆
包缝时机针线紧	①机针上挑线出线量不够	将机针上挑线移出一些,使每针送出足够线量
	②机针线夹线板压力过紧	旋松机针线夹线板螺母
	③下弯针出线量过多或下弯针线夹线板压力过松	减少下弯针出线量或旋紧下弯针线夹线螺母使出线均匀
上弯针线紧或松	①上弯针位置未调好,过高或过低	调节上下弯针使出线均匀
	②上弯针线夹线板压力过紧或过松	旋松或旋紧上弯针线夹线螺母
下弯针线紧或松	①上弯针摆杆过线位置未调好,过高或过低	调节上下弯针使出线均匀
	②下弯针线夹线板过紧或过松	旋松或旋紧夹线板达到微量压力即可,绝不能有过大压力
链线勾针线紧	①链线调节板装得太进使链线勾针出线量不够,造成机针线被拉下来	链线勾针出线量调节在7~8mm
	②链线穿线板上下位置未调好,造成链线勾针出线时间提早或延迟	重新调节穿线板位置
上弯针线跳线	①机针与上弯针定位不准	机针与上弯针,上叉针的定位
	②机针与上弯针间隙太大	机针与上弯针的间隙均为0.05mm
下弯针线跳线	①机针弯或针尖毛	调换机针
	②针眼方向不正	调整针眼方向,使机针长槽对准操作者
	③下弯针针头不尖	修磨下弯针针头或予以调换
	④护线板没有装准	调整护线板位置,使护线板靠拢机针护线和护针间隙均不大于0.01mm
交叉跳针	①上弯针与下弯针相交处的间隙太大	将上弯针或下弯针安装位置偏角放大些,上弯针与下弯针交叉时的间隙为0.10mm
链式跳针	①链线勾针定位不准	五线机器的下弯针,到机针的距离为3.5~4mm,下弯针高度为R64.7~65.2mm
	②链线挑线杆位置未调好,使链线勾针的线收不上,不能产生线环引起勾针	调节链线挑线杆位置,达到缝料间断时出辫子线迹
	③链线弯针线夹线板压力太松	微量旋紧链线弯针线夹线螺母

4. 常见故障和调整

故障现象	产生原因	调整方法
断机针线	①机针线夹板压线力过紧	旋松机针线夹线螺母
	②机针针尖毛	调整机针
	③下弯针针尖毛	修磨下弯针针尖或更换下弯针
	④送布牙有刃口	修磨或抛光送布牙齿面
	⑤小针板边缘有毛刺	将小针板边缘修光或抛光
断上弯针线	①缝线穿错或上弯针线夹板线板压力过大	穿线时应先穿弯针线,后穿机针线或旋松上弯针线夹线板螺母
	②上弯针针眼毛	在弦线涂上抛光膏,穿进上弯针针眼内将孔拉光
断下弯针线	①缝线穿错或下弯针线夹板线板压力过大	穿线时应先穿弯针线,后穿机针线或旋松下弯针线夹线板螺母
	②下弯针将小针板碰毛,引进断线	修磨小针板,适当调低下弯针高度
	③下弯针针眼毛	在弦线涂上抛光膏,穿进下弯针针眼内将孔拉光
断链线勾针线	①缝线穿错或过线器不光滑	穿线时应先穿弯针线,后穿机针线或除去过线器上的毛刺使其光滑
	②送布牙有刃口	修磨或抛光峰口或者更换新品
断链线机针线	①机针链线勾针定位不准	五线机器的链线勾针尖到机针的距离为2.5~3mm,链线勾针高度为R58~59mm
	②链线机针线夹线板压力过紧	旋松链线机针线夹线螺母
	③链线勾针针尖与机针距离太大	调整链线勾针针尖与机针距离间隙为0.05mm
	④机针弯或针尖毛	调换机针
	⑤机针槽方向不正	调整机针槽方向,使机针长槽对准操作者
	⑥链线勾针针尖钝	修磨链线勾针针尖或调换弯针
	⑦链线护针架没有装准	调整链线护针架位置,使其靠拢机针,护线和护针的间隙均不大于0.01mm
断机针	①下弯针定位不准,将机针勾断	调节下弯针位置,下弯针倾斜角度均为3°~6°,下弯针与机针的间隙均为0.05mm
	②机针尖与针杆中心不平行,缝厚料时断针	校正针杆头或调换针夹使机针中心和针杆中心平行
	③护针架位置不对	调整护针架位置,护线和护针的间隙均不大于0.10mm
	④压脚槽与机针没有对准	调节压脚槽位置与机针对准
	⑤穿线方法不正确	正确穿线
	⑥机针安装错误	重新装机针,长槽正面向你自己
缝合起皱	①送料逆差比太小,不协调	将差动扳手向下移,直至缝料平整为止
	②压脚底面与送料牙平面不平	压脚应与牙齿面装平,不得左右翘起,调节压脚
	③压脚压力太强或太弱	调整压脚压力强度
	④刀钝	磨利刀片或换新品
	⑤针太粗	用适宜布和线的机针
	⑥包边宽度比针板舌狭窄	调整包边宽度或换针板

4. 常见故障和调整

故障现象	产生原因	调整方法
上、下层缝	①压脚压力过松	增加调压螺钉压力
	②压脚压力太大或不平	抛光压脚底部或装平压脚
	③差动牙齿与送料牙齿面高度不一致	调整送料牙的而高度,使二齿面应平齐
切边不整齐	①刀位置不正确	调整刀到正确位置
	②上、下刀片钝	磨利或换新品
缝线不均	①穿线错误	重新正确穿线
	②线架安装错误	重新装线架使线能通过自如
	③下刀位置不正确	调整刀到正确位置
	④刀切边不整齐	研磨下刀或更换上刀
	⑤过线孔有毛刺	过线孔重新拉光
	⑥针尖受损	换新针
	⑦送料牙高度不适应	调整正确高度
	⑧压脚压力太强或太弱	调整压脚压力强度
声响	①机件松动或相互碰撞	仔细检查各部位零件,然后旋紧各部位螺钉纠正碰撞或松动现象
	②油路阻塞	拆卸油盘后,清洗油泵外部垃圾,使油泵进出油畅通
	③油盘橡皮垫未垫平	检查油盘和底盘间是否有碰撞声,如有须将其垫放平整,使之不碰
漏油	①送料牙架防油板损坏或盖板未盖平	调换防油板,检查其它部位或换密封橡皮,使各部位盖板盖平,然后旋紧各盖板螺钉

4. Trouble Shooting

If you notice any of the problems listed below, refer to the Remedy column for instructions on how to solve the problem.

If this cannot solve the problem, or if the problem you are experiencing is not listed below, contact our dealer nearest you or a qualified technician to carry out the necessary adjustment.

Phenomena	Possible cause	Remedy
Needle thread is lax	① Needle thread pressure is too lax	Fasten needle thread tension screw
	② The thread is get too much	Adjust needle thread bar make thread get little
	③ Lower looper thread guide press to tight lead needle thread go down	Turn lax to lower looper thread guide screw or adjust lower looper thread take-up lever
Thread too tight	① Needle take-up thread not enough	Move out upper needle a litter make thread gave more
	② Thread tension disc too tight	Loosen thread tension nut
	③ Thread get too much from lower looper	Tight lower looper thread tension nut
Too tight or lax of upper looper	① Upper looper not fixed in the right place	Adjust upper and lower looper make thread get
	② Upper looper tension disc too tight or lax	Tighten or loosen thread tension nut
Upper looper thread too tight or lax	① Upper needle bar not fixed in the right place	Adjust upper looper make thread gave properly
	② Lower looper thread tension disc too tight to lax	Loosen or tighten thread tension disc
Chain thread looper too tight	① Chain thread tension disc fixed too inner make the thread get not enough	Chain thread looper fixed 7-8cm
	② Chain thread guide plate not fixed in the right place	Adjust the place in the right place
Upper looper thread make stitch skipped	① Looper and needle not fixed in the right place	Adjust them to a right place
	② Long distance between needle and upper looper	The distance should be adjusted to 0.05mm between needle and upper looper
Lower looper make stitch skipped	① Needle not straight or rough	Change the needle
	② Hole of needle not in the right orientation	Adjust the needle make the groove point to the operator
	③ Lower looper not peak enough	Make it peak or change it
	④ Thread guide not fixed in the right place	Thread guide plate fixed to a right place make the distance between plate and needle no more than 0.0.1mm

4. Trouble Shooting

Phenomena	Possible cause	Remedy
Cross skip	①The distance of the cross point between upper looper and lower too far	Fixed the distance to 0.10mm
Chain pattern skip	①Chain thread needle not fixed in the right place	Five threads lower looper should 3.5-4mm away from needle the high to lower looper should 64.7-65.2mm
	②Chain thread looper bar not fixed in the right place	Adjust the looper bar, make the braid stitch seen when no material fed
	③Chain thread tension disc too lax	Tighten the nut by a litter
Thread of needle cut	①Thread tension disc too tight	Loosen the nut
	②Needle too rough	Change needle
	③Lower looper rough	Change or polish the needle
	④Feed dog too sharp in some part	Polish the feed dog
	⑤Small needle plate sharp in some place	Polish the needle plate
Upper looper thread cut	①Chain thread pass through in the wrong way or thread tension disc too tight	Thread of looper should pass through before needle thread or loosen cut
	②Hole of upper looper rough	Polish the hole by the tension thread with the polish paste
Chain thread cut	①Thread through in wrong way or the thread guide rough	Looper thread should through before needle, or polish the thread guide
	②Some sharp part of feed dog	Polish feed dog or change one
Chain thread cut	①Chain thread looper not fixed in the right place	Five thread chain looper should 2.5-3mm away from needle, height of chain thread should be R58-59mm
	②Chain thread looper thread tension too tight	Loosen the nut
	③The point of chain thread looper is too far away from needle	Adjust chain thread looper make the distance between them 0.05mm
	④Needle bended or needle point rough	Change the needle
	⑤The groove of needle is not point to the right orientation	Change the orientation point to the operator
	⑥Chain thread looper blunt	Make looper sharp or change the looper
	⑦Guide of chain thread looper not fixed properly	The thread should 0.01mm away from needle guide
Lower looper make stitch skipped	①Lower looper not fixed in the right place	Adjust the lower looper the angle should 3°-6°, lower looper should 0.05 mm away from needle
	②Needle in not paralleled to the needle bar	Parallel them by adjust or replaced

零件目录 PARTS CONTENTS

1. 机壳部件	1
Frame Components	
2. 主轴部件	5
Main Shaft Components	
3. 机针驱动部件	7
Needle Driving Components	
4. 差动部件	11
Differential Feed Mechanism Components	
5. 上下切刀部件	15
Upper&lower Knife Components	
6. 上下弯针部件	17
Upper&lower Looper Components	
7. 前弯针部件(五六线专用)	19
Chain Looper Components (for five & six thread)	
8. 抬压脚部件	23
Presser Footlifter Components	
9. 供油部件	25
Lubrication Mechanism Components	
10. 附件部件	27
Accessories Components	
11. 直驱部件	29
Direct Drive Assemblies	

4. Trouble Shooting

Phenomena	Possible cause	Remedy
	③ Needle bracket is not fixed in the right place	Adjust the needle bracket make thread 0.1mm away from needle guide
	④ Foot groove not match the needle	Adjust the foot groove to match needle
	⑤ Thread not through in the correct way	Through in the correct way
	⑥ Needle not properly fixed	Make sure needle groove point to the operator
Poor thread tightening	① Differential ratio too small	Increase differential ratio till the material flat
	② The bottom of foot is not paralleled to the feed dog	Parallel them
	③ The pressure of foot is too heavy or too light	Adjust the pressure
	④ Knife can't cut immediately	Make it sharp or change a new one
	⑤ Needle too big	Make needle match material
	⑥ Width of locked part less than needle plate	Change the width or replace the needle plate
1locked respectively of the layer	① Pressure of the foot too much or not flat	Increase the pressure
	② Resistance of foot too much or not flat	Polish the foot or make it flat
	③ Feet dogs are not parallel	Change the height of feet dog to make them parallel
Trimmer edge not orderly	① Knife fixed wrong	Make the knife in the right position
	② Knife blunt	Make knife sharp or replaced
Stitch is not equably	① Thread through in wrong way	Make the thread through in the correct way
	② Thread bracket fixed in wrong way	Adjust the thread bracket make thread pass easily
	③ Knife bottom fixed in the wrong way	Adjust the knife bottom
	④ Trimmer edge out of order	Skive lower knife or change upper knife
	⑤ Hole for thread broken	Polish the hole edge
	⑥ Needle point broken	Change to a new one
	⑦ Feeding device not in the right height	Adjust the height
	⑧ Pressure of foot too heavy or light	Adjust the pressure
Noise	① Parts loosen and collide with each other	Check the machine comprehensively then tighten all the loosen parts
	② Lubrication system blocked	Clear the pump make oil get through fluently
	③ Rubber mat out of palce	Make sure the mat put in the right place without noise uttered
Oil leak	① Oil prevent plate of feed dog	Replace the broken part and tight the screw

1.机壳部件 Frame Components

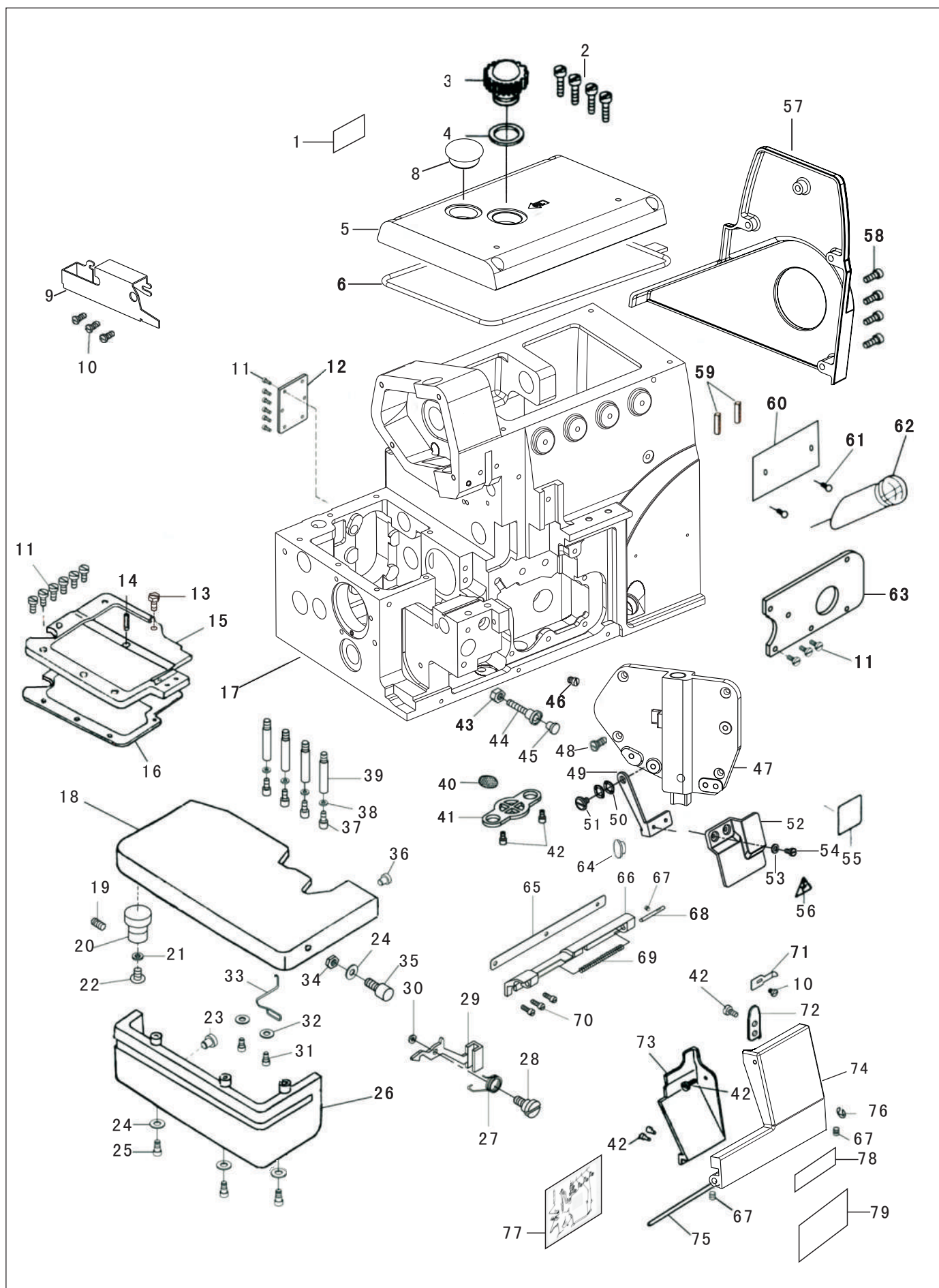

1.机壳部件 Frame Components

序号 NO.	图号 REF NO.	名称	DESCRIPTION	数量 AMT		
				3线	4线	5线
1	44-0000004-00	Ce标签	The Ce label	1	1	1
2	11-40111225-01	螺钉	Screw Sm11/64×40 L=12	4	4	4
3	203-01-25	示油窗	Oil Window	1	1	1
4	209-02-05	油窗垫	Oil Window Washer	1	1	1
5	2321-01-02	上盖	Upper Cover	1	1	1
6	2320-01-10	上盖油封	Oil Seal Washer	1	1	1
7	44-0000001-00	安全注意标签	Security Lable	1	1	1
8	2316-02-04	上盖橡皮塞	Plug	1	1	1
9	2321-01-05	导布板	Cloth Plate Side Cover	1	1	1
10	11-40110525-01	盖板螺钉	Cover Plate Screw Sm11/64×40 L=5	3	3	3
11	11-40110825-01	螺钉	Thread Guide Rod Screw Sm11/64 ×40 L=8	15	15	15
12	279-01-19-00	后盖板组件	Back Cover Plate	1	1	1
13	11-90110820-01	螺钉	Screw Sm11/64×40 L=8	1	1	1
14	43-20300000-00	油线	Oil Wick	0.03	0.03	0.03
15	279-01-11	左上盖	Upper Cover (left)	1	1	1
16	279-01-10	盖板垫片	Cover Plate Gasket	1	1	1
17	2321-11-01	机壳	Machine	1	1	1
18	205-01-10-00	缝台组件	Sewing Machine Components	1	1	1
19	11-80111212-01	紧定螺钉	Screw Sm11/64×40 L=12	1	1	1
20	205-01-10-02	缝台偏心轴套	Eccentric Bushing	<1>	<1>	<1>
21	22-05000000-08	弹性垫片	Flexible Washer	<1>	<1>	<1>
22	205-01-10-04	螺钉	Screw	<1>	<1>	<1>
23	279-01-50	缝台橡胶垫	Needle Plate Bracket Rubber Cushion	1	1	1
24	21-04308090-01	缝台下罩壳垫圈	Cloth Plate Lower Cover Washer	4	4	4
25	11-40091325-01	下罩壳固定螺钉	Lower Cover Fixing Screw Sm9/64×40 L=13	3	3	3
26	205-01-13	缝台下罩壳组件	Cloth Plate Lower Cover Asm.	1	1	1
27	279-01-52	缝台闸弹簧	Cloth Plate Latch Spring	1	1	1
28	279-01-60	缝台闸固定螺钉	Cloth Plate Fixing Screw	1	1	1
29	279-01-53	缝台闸	Cloth Plate Latch	1	1	1
30	21-05020100-01	垫片	Washer	1	1	1
31	11-40080425-01	螺钉	Needle Thread Cover Fixing Screw Sm1/8 ×44 L=4	2	2	2
32	21-03405070-01	缝台弹簧紧定小垫片	Cloth Plate Spring Locking Little Washer	2	2	2
33	279-01-46	缝台弹簧	Cloth Plate Spring	1	1	1
34	13-60093020-01	螺母	Nut Sm9/64 ×40	1	1	1
35	279-01-59	缝台锁紧定位销	Cloth Plate Locking Position Pin	1	1	1
36	279-02-81	缝台橡胶垫	Needle Plate Bracket Rubber Cushion	1	1	1
37	11-60151122-01	内六角螺钉	Hexagonal Socket Screw Sm15/64×28 L=11.2	4	4	4
38	21-06520150-01	垫片	Washer	4	4	4
39	279-01-27	支柱	Column	4	4	4
40	2304-01-08	滤油网	Filter Screen	1	1	1
41	293-01-14	滤油网压板	Clip Spring	1	1	1
42	11-40090625-01	螺钉	Screw	6	6	6
43	13-60113020-01	锁紧螺母	Locking Screw Sm11/64×40	1	1	1
44	279-01-61	缝台定位调节螺钉	Cloth Plate Stopped Adjusting Screw	1	1	1
45	279-02-81	定位垫圈	Retaining Washer	1	1	1
46	11-60160520-01	螺塞	Rubber Plug Sm1/4×40 L=7	1	1	1
47	2321-01-05	侧盖板	Side Cover	1	1	1
48	11-40110825-01	螺钉	Screw	4	4	4
49	2316-02-27	安全板支架	Safety Guard Bracket	1	1	1
50	23-06503110-09	波形垫圈	Washer	2	2	2
51	209-03-13	螺钉	Screw	1	1	1
52	2320-01-11	防护罩	Protective Cover	1	1	1

1.机壳部件 Frame Components

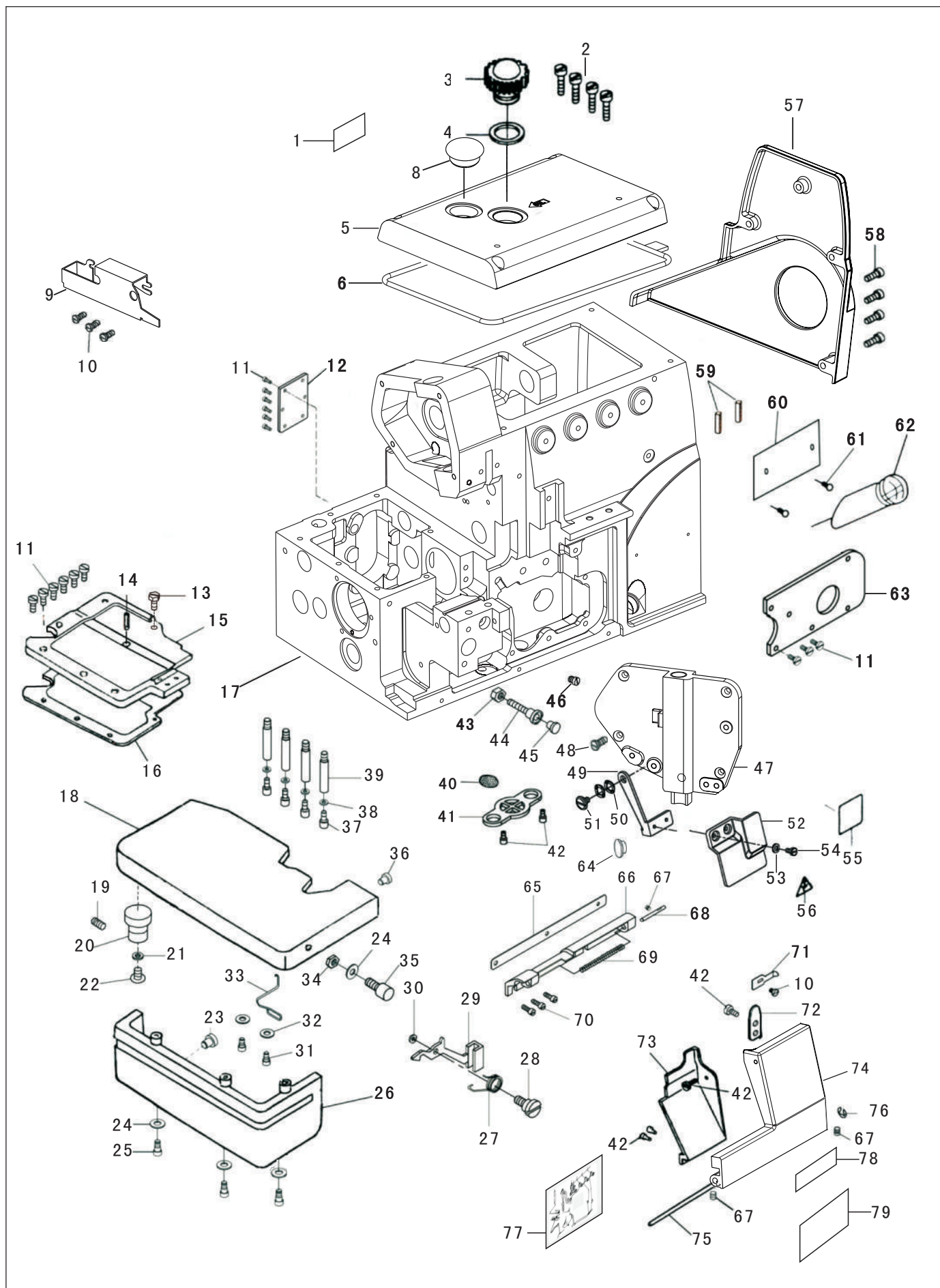

1.机壳部件 Frame Components

序号 NO.	图号 REF NO.	名称	DESCRIPTION	数量 AMT		
				3线	4线	5线
53	21-03405070-01	防护罩垫圈	Washer	2	2	2
54	12-60300520-01	防护罩螺钉	Screw	2	2	2
55	2320-01-08	机头牌	Head Card	1	1	1
	279-11-26-1	757机头罩 (GEMSY)	Head Card	1	1	1
56	44-00000005-00	安全标记	Safety Symbol	1	1	1
57	2321-01-07	皮带罩	Belt Cover	1	1	1
58	11-40111225-01	带轮罩螺钉	Pulley Guard Screw Sm11/64 ×40 L=12	4	4	4
59	279-01-04	过线管	Thread Guide Tube	2	2	2
60	2320-01-09-03	三线型号牌	Indicate Plate	1		
	2320-01-09-04	四线型号牌	Indicate Plate		1	
	2320-01-09-05	五线型号牌	Indicate Plate			1
61	101-01-14	商标牌铆钉	Trade Mark Plate Rivet	2	2	2
62	293-01-13	圆柱形油窗	Oil Window	1	1	1
63	279-01-57-00	盖板组件	Cover components	1	1	1
64	120-01-06	油封	Oil Seal	1	1	1
65	279-01-99	密封垫	Gasket Washer	1	1	1
66	279-01-94	前罩壳下铰链	Front Cover Lower Hinge	1	1	1
67	11-80110512-01	防转销螺钉	Driving Pin Screw Sm11/64 ×40 L=5	1	1	1
68	279-01-97	防转销	Driving Pin	1	1	1
69	279-01-96	铰链销弹簧	Hinge Pin Spring	1	1	1
70	279-01-116	铰链螺钉	Hinge Screw Sm9/64 ×40 L=7.5	3	3	3
71	279-01-101	前盖板锁紧舌	Front Cover Locking Fastener Tongue	1	1	1
72	279-01-102	前盖板锁紧板	Front Cover Locking Plate	1	1	1
73	2321-01-100	五线前盖板罩板	Five-thread Front Cover Plate			1
	2321-01-100B	三、四线前盖板罩板	Thread 、 four-thread Front Cover Plate	1	1	
74	2321-01-100	前罩壳	Front Cover	1	1	1
75	2321-01-100B	铰链销	Hinge Pin	1	1	1
76	24-03000000-08	铰链销卡簧	Hinge Pin Spring	1	1	1
77	279-01-100-03	穿线图	Wearing Map	1		
	279-01-100-04	穿线图	Wearing Map		1	
	279-01-100-05	穿线图	Wearing Map			1
78	44-00000003-31	DC×27 11机针标签	Needle Label Dc X 27 11 #	1	1	
	44-00000003-30	DC×27 14机针标签	Needle Label Dc X 27 14 #			1
79	44-00000001-00	安全注意标签	Security Label	1	1	1
80	44-00000011-00	产品合格证(宝石牌)				
	44-00000013-00	通用合格证(空白)				
81	11-80090412-01	螺钉				
82	44-00000012-00	MADE IN CHINA标签				
83	44-00000007-00	加油标签				

2. 主轴部件 Main Shaft Components

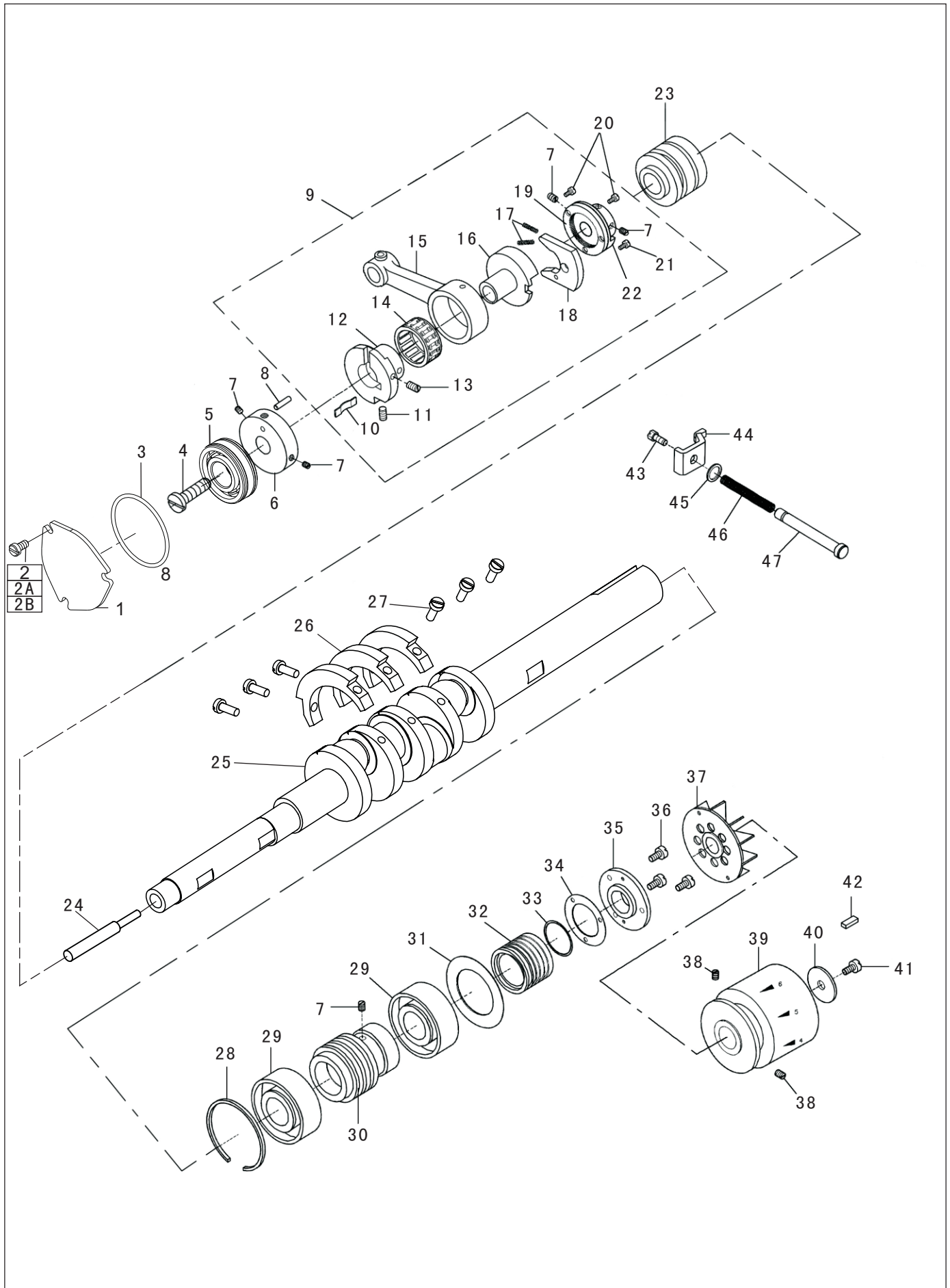

2.主轴部件 Main Shaft Components

序号 NO.	图号 REF NO.	名称	DESCRIPTION	数量 AMT		
				3线	4线	5线
1	2316-03-05	主轴左轴承密封盖	Sealed Cap	1	1	
2	12-40400825-01	主轴左轴承密封盖螺钉	Screw	3	3	0
2A	12-10401020-01	主轴左轴承密封盖螺钉	Screw			2
2B	12-60401020-01	主轴左轴承密封盖螺钉	Screw			1
3	31-04020000-09	主轴左轴承O型圈	O Ring	1	1	1
4	11-60141520-01	主轴堵螺钉	Main Shaft Screw Sm7/32 ×32 L=3+11.6	1	1	
5	2321-02-25	主轴左轴承组件	Ball Bearing Ass'y	1	1	1
6	2320-02-01	孔用挡圈	Hole Thrust Ring	<1>	<1>	<1>
7	11-80110512-01	紧定螺钉	Worm Set Rivet Sm11/64 ×40 L=5	5	5	5
8	279-05-63	销子	Feed Eccentric Wheel Pin	<1>	<1>	<1>
9	279-05-64-00	送布组件	Feed Asm.	1	1	1
10	279-05-67	弹簧	Spring	<1>	<1>	<1>
11	11-80110512-01	内六角紧定螺钉	Hexagonal Socket Set Screw Sm11/64"×40 L=5	<1>	<1>	<1>
12	279-05-66	偏心轮	Eccentric Wheel	<1>	<1>	<1>
13	279-05-97	内六角紧定螺钉	Hexagonal Socket Set Screw Sm11/8×44 L=2.8	<3>	<3>	<3>
14	279-05-65	送布连杆滚针轴承	Feed Connection Rod Needle Bearing	<1>	<1>	<1>
15	279-05-64	送布连杆	Feed Connection Rod	<1>	<1>	<1>
16	279-05-68	针距凸轮	Needle Gague Cam	<1>	<1>	<1>
17	279-05-71	弹簧	Spring	<2>	<2>	<2>
18	279-05-69	扇形齿环	Segment Gear Collar	<1>	<1>	<1>
	279-05-70	扇形齿环固定滑块	Segment Gear Collar Set Block	<1>	<1>	<1>
	279-05-99	扇形齿环螺钉	Segment Gear Collar Screw Sm3/32×56 L=6	<2>	<2>	<2>
19	279-05-73	调质定位齿圈	Regulating Set Gear Ring	<1>	<1>	<1>
20	279-05-101	螺钉	Screw Sm11/8×40 L=4.4	<2>	<2>	<2>
21	279-05-100	螺钉	Screw	<1>	<1>	<1>
22	279-05-72	齿圈座	Gear Ring Bracket	<1>	<1>	<1>
23	279-02-03	主轴中轴套组件	Main Shaft Intermediate Bushing Asm.	1	1	1
24	2304-02-01	油量销	Pin	1	1	1
25	2320-02-03	主轴组件	Main Shaft	1	1	1
26	2320-02-02	平衡块	Balance Weight	3	3	3
27	12-40300825-01	螺钉	Screw	6	6	6
28	28-33014370-09	孔用弹性挡圈	Hole Flexible Thrust Ring	1	1	1
29	279-02-24	带密封单列向心球轴承	Ball Bearing	2	2	2
30	2320-02-05	蜗杆	Worm	1	1	1
31	23-26005340-09	弹性垫圈	Flexible Washer	1	1	1
32	279-02-06	油封	Oil Seal	1	1	1
33	31-16618000-09	O形密封	O Gasket	1	1	1
34	279-02-09	后轴承盖垫片	Back Bearing Cover Washer	1	1	1
35	279-02-10	后轴承盖	Back Bearing Cover	1	1	1
36	11-40110825-01D	后轴承盖螺钉	Back Bearing Cover Screw Sm11/64 ×40 L=8	3	3	3
37	279-02-11	叶轮	Leaf Wheel	1	1	1
38	11-80150810-01	带轮紧定钉	Pulley Set Screw Sm15/64 ×28 L=8.5	2	2	2
39	203-01-06	皮带轮	Pulley Set Key	1	1	1
40	21-08025251-01	垫圈	Washer	1	1	1
41	11-40151525-01	带轮轴向固定螺钉	Pulley Shaft Stopper Rivet Sm15/64 ×28 L=14	1	1	1
42	279-02-107	定位键	Setkey	1	1	1
43	11-90110820-01	固定螺钉	Fixing Screw Sm11/64×40 L=8	1	1	1
44	279-05-85	针距调节块	Needle Gague Regulating Support	1	1	1
45	31-06718000-09	密封圈	Gasket Washer	1	1	1
46	279-05-83	弹簧	Spring	1	1	1
47	279-05-82	针距调节轴	Needle Gague Regulating Shaft	1	1	1

3.机针驱动部件 Needle Driving Components

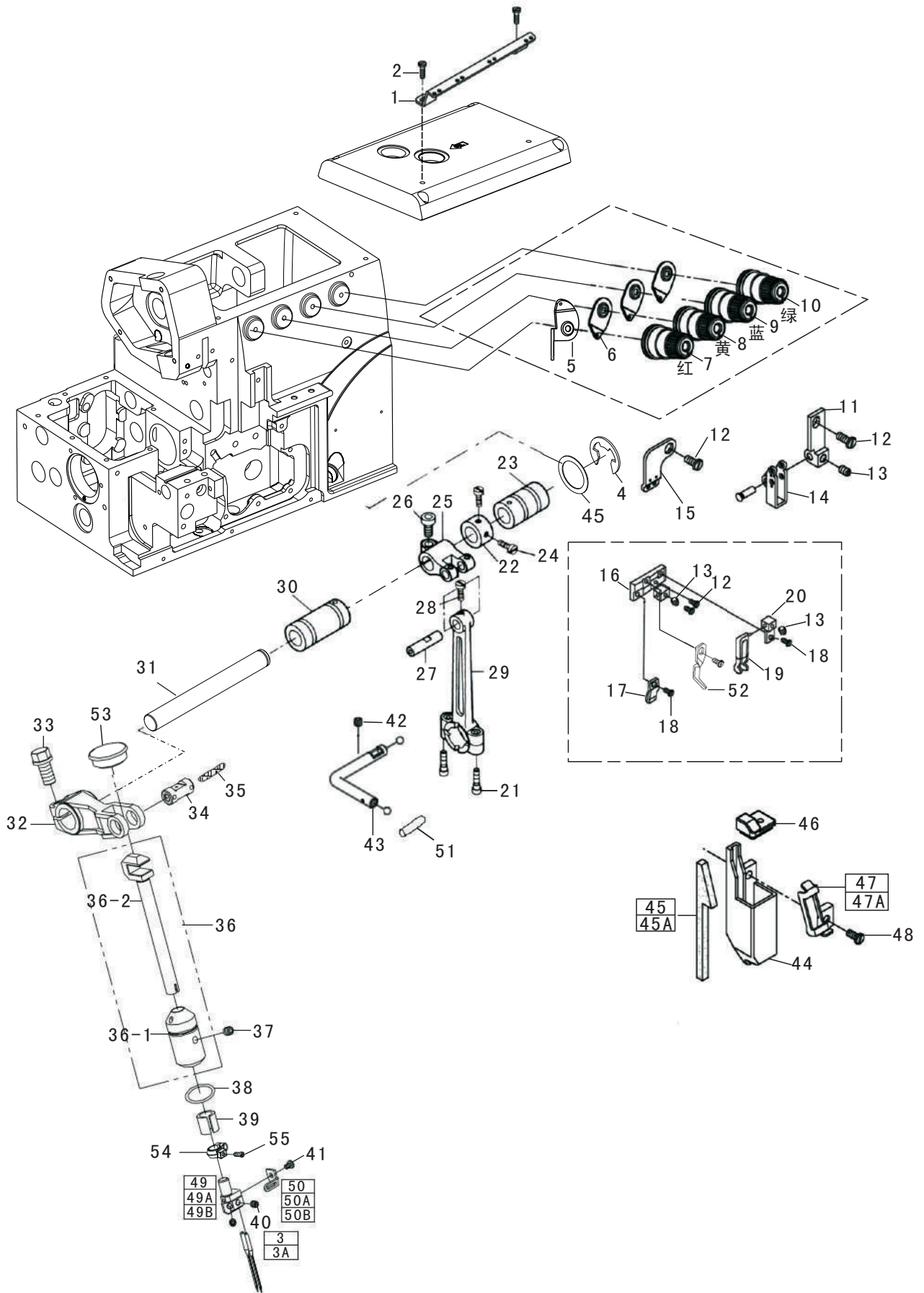

3.机针驱动部件 Needle Driving Components

序号 NO.	图号 REF NO.	名称	DESCRIPTION	数量 AMT		
				3线	4线	5线
1	2316-04-02	导线杆	Wire Rod	1	1	1
2	12-40400625-01	导线杆螺钉	Screw	4	4	4
3	279-02-30	机针DC*27 #11	Needle	1	2	
3A	279-02-30A	机针DC*27 #14	Needle			2
4	24-08000000-09	针杆摆动轴开口挡圈	Open Ring	1	1	1
5	2321-04-05	机针过线板	Needle Thread Plate		<1>	<1>
6	2316-04-04	夹线器过线板	Thread Clamp Device Line Board		<3>	<3>
7	2316-04-01A	面线夹线器组件(红点)	Line Thread Clamp Device Components		<1>	<1>
8	2316-04-01B	面线夹线器组件(黄点)	Line Thread Clamp Device Components		<1>	<1>
9	2316-04-01C	底线夹线器组件(蓝点)	The Bottom Line Thread Clamp Device Components		<1>	<1>
10	2316-04-01D	底线夹线器组件(绿点)	The Bottom Line Thread Clamp Device Components		<1>	<1>
11	2316-05-02	上挑线过线板支架	Pick Up Line On Line Board Bracket	1	1	1
12	12-40400825-01	上挑线过线板销紧固螺钉	Screw	2	2	2
13	12-80400412-01	上挑线过线板销紧固螺钉	Screw	1	1	2
14	2316-05-01A	三线上挑线过线板组件	Three Lines On The Pick Line Line Board Components	1		
	2316-05-01	四线上挑线过线板组件	Four Online Pick Line Line Board Components		1	
15	2316-05-03A	三线针杆过线板	Three Wire Needle Bar Line Board	1		
	2316-05-03	四线针杆过线板	Four Wire Needle Bar Line Board		1	
16	2316-05-17	挑线过线支座	Pick A Line Support			1
17	2316-05-21	机针上过线	The Thread On The Needle			1
18	12-80400412-01	机针上过线螺钉	Screw			3
19	2316-05-22	机针下过线	Under The Needle Thread			1
20	2316-05-19	挑线上过线支架	Support Line Crossed The Line			1
21	11-40091225-01	针杆摆动连杆螺钉	Screw	2	2	2
22	279-06-07	针杆摆动轴挡圈	Needle Bar Rock Shaft Thrust Ring	1	1	1
23	279-05-09	机针传动后轴承	Needle Driving Back Bearing	1	1	1
24	11-00140710-01	螺钉	Screw	2	2	2
25	2321-03-04	机针摆轴曲柄	Balance Shoe	1	1	1
26	2316-06-32	机针摆轴曲柄螺钉	Screw	1	1	1
27	279-02-41	连杆销	Connection Lever Pin	1	1	1
28	11-90110820-01	六角螺钉	Upper Cover (left) Hexagon Screw	1	1	1
29	2321-03-05	机针传动连杆组件	Needle Driving Connecting Rod Components	1	1	1
30	293-03-06	机针传动前轴承	Needle Bar Rock Shaft	1	1	1
31	293-03-07A	针杆摆轴	Connection Link Fixing Screw M6 ×13.5	1	1	1
32	2316-06-03	针杆摆动曲柄	Lever	1	1	1
33	2316-06-32	针杆摆动曲柄夹紧螺钉	Bolt	1	1	1
34	2316-06-08	针杆摆动曲柄销	Pin	1	1	1
35	2316-06-07-01	针杆摆动曲柄销油线	Oil Line	1	1	1
36	2316-06-09	针杆组件	Needle Bar Component	1	1	1
36-1	2316-06-09-01	针杆下轴套	Needle Bar Under The Bush	1	1	1
36-2	2316-06-09-02	针杆	Needle Bar	1	1	1
37	12-80400542-01	针杆下轴套紧固螺钉	Screw	1	1	1
38	31-11515000-09	针杆下轴套O型圈	O Ring	1	1	1
39	2316-06-10	针夹轧头圈	Felt	1	1	1
40	11-80300312-01	支针螺钉	Screw	1	1	1
41	12-60200320-01	针夹导向板螺钉	Screw	1	1	1
42	11-80110512-01	内六角紧定螺钉	Hexagonal Socket Set Screw Sm11/64"x40 L=5	1	1	1
43	2316-13-19	针杆供油管组件	Needle Bar For Tubing Components	0.23	0.23	0.23
44	2316-02-32	小油箱	Small Tank	1	1	1
45	2316-02-33	油毡	Felt	1	1	
	2316-02-33A	油毡	Felt			1
46	2316-02-32	面线硅油盒盖	Line Silicone Oil Lifted The Lid	1	1	1

3.机针驱动部件 Needle Driving Components

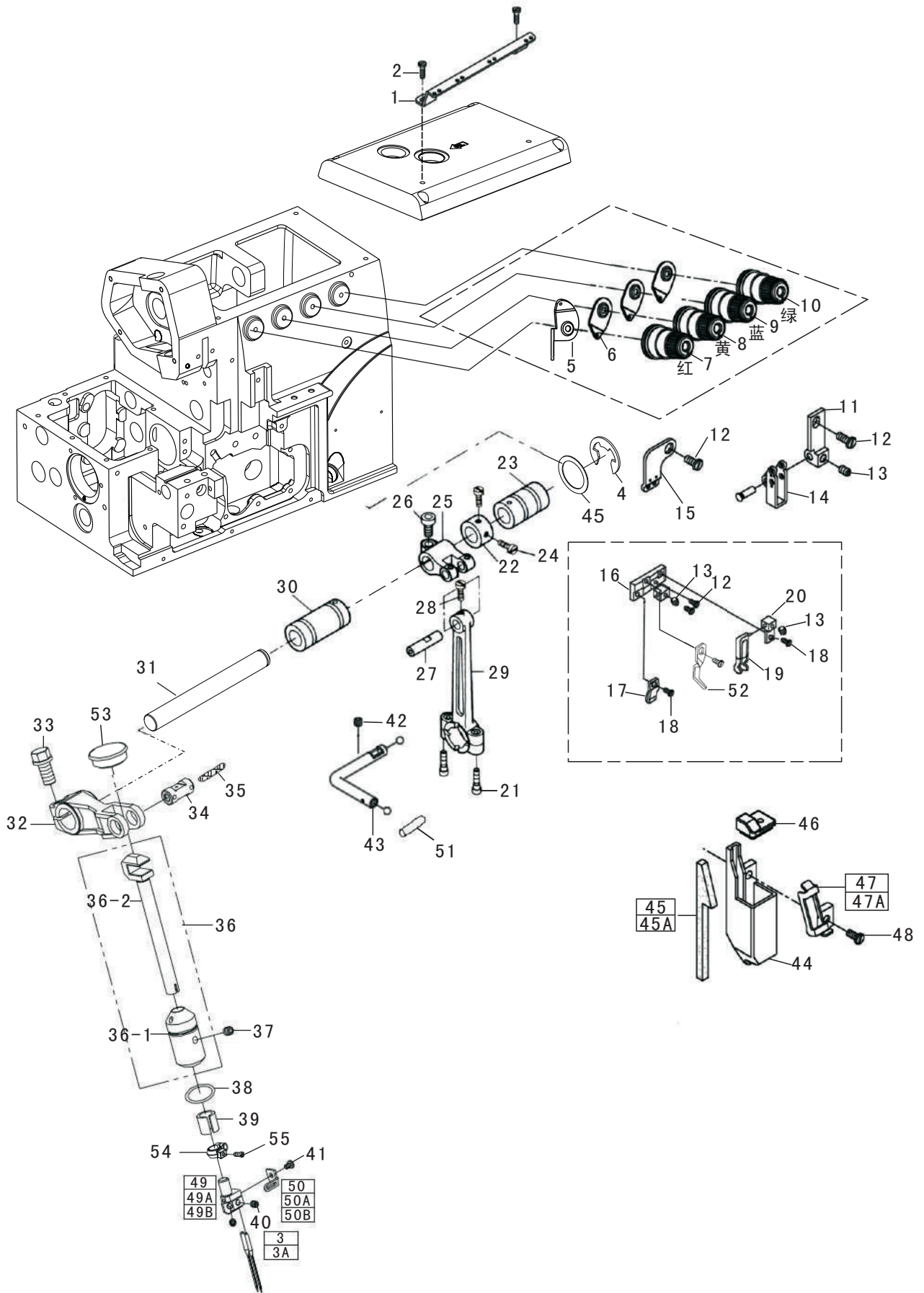

3.机针驱动部件 Needle Driving Components

序号 NO.	图号 REF NO.	名称	DESCRIPTION	数量 AMT		
				3线	4线	5线
47	2316-02-34	面线硅油盒过线架	The Thread Line Silicone Oil Box	1	1	
	2316-02-34A	面线硅油盒过线架	The Thread Line Silicone Oil Box			1
48	11-40111025-01D	导线杆螺钉	Screw	1	1	1
49	2316-06-12	三线针夹	Needle Holder Assy.			1
49A	2316-06-12A	四线针夹	Needle Holder Assy.		1	
49B	2316-06-12B	五线针夹	Needle Holder Assy.			1
50	2316-06-13	五线针夹导线板	Thread Guide			1
50A	2316-06-13A	四线针夹导线板	Thread Guide		1	
50B	2316-06-13B	三线针夹导线板	Thread Guide	1		
51	41-20301600-00	开口销	Snap Pin	1	1	1
52	2316-05-22	机针下过线	Under The Needle Thread	1	1	1
53	209-10-24	针杆孔上橡皮塞	Plug	1	1	1
54	2316-06-11	针夹轧头				
55	12-60300620-01	针夹轧头夹紧螺钉				
56	2316-05-04	三、四线压线底板				
57	2316-05-05	三、四线压线上板				
58	2316-05-06	三、四线压线簧				
59	2316-05-07	三、四线压线螺钉				
60	2316-02-34	面线硅油盒过线架				
61	11-80080312-01	针夹头螺钉				

4. 差动部件 Differential Feed Mechanism Components

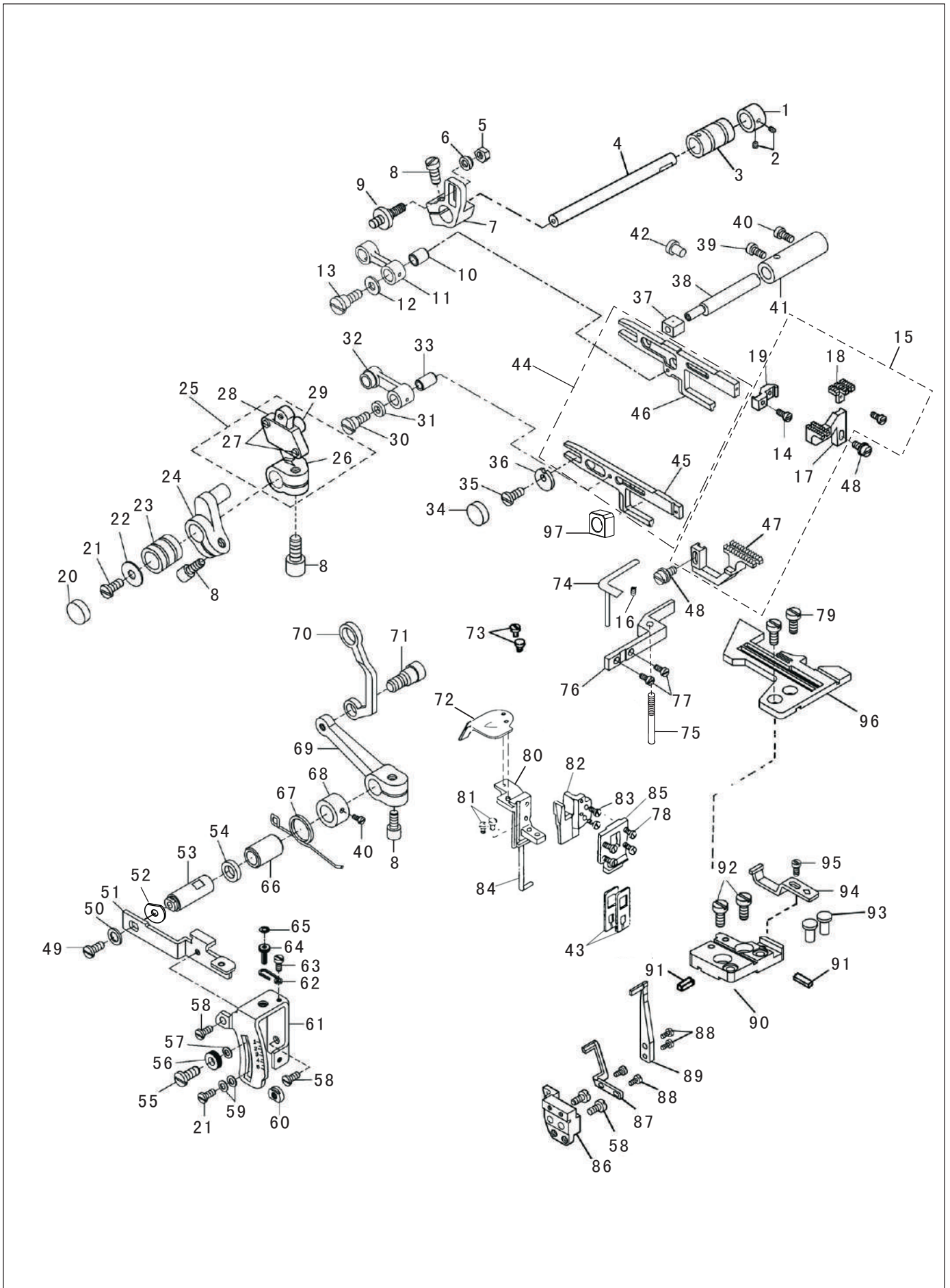

4.差动部件 Differential Feed Mechanism Components

序号 NO.	图号 REF NO.	名称	DESCRIPTION	数量 AMT		
				3线	4线	5线
1	279-06-07	挡圈	Thrust Ring	1	1	1
2	11-00140710-01	螺钉	Balance Shoe Fixing Screw Sm7/32 ×32 L=6.4	2	2	2
3	279-05-09	送布轴铜轴承	Feed Shaft Copper Bearing	1	1	1
4	279-05-10	送布轴	Feed Shaft	1	1	1
5	13-60145520-01	螺母	Crank Regulating Pin Nut Sm7/32×32	1	1	1
6	279-05-08	垫圈	Washer	1	1	1
7	279-05-06	送布调整曲柄	Feed Adjusting Crank	1	1	1
8	11-60151522-01	圆柱头内六角螺钉	Thread Guide Washer Sm15/64 ×28 L=15	4	4	4
9	279-05-07	送布牙连杆偏心轴	Feed Dog Connection Link Eccentric Shaft	1	1	1
10	279-05-21	送布牙连杆套	Feed Bar Connection Link Bushing	1	1	1
11	279-05-20	送布牙架连杆	Feed Bar Holder Connection Link	1	1	1
12	21-04615122-02	送布牙架连杆套垫圈	Feed Bar Holder Connection Link Bushing Washer	1	1	1
13	279-05-47	送布牙架连杆套螺钉	Feed Bar Holder Connection Link Bushing Screw	1	1	1
14	11-40090725-01	螺钉	Screw SM9/64 ×40 L=4	1	1	1
15	279-05-34-03	三、四线送布牙组件	Three-thread Feed Dog Asm.	1	1	
	279-05-34-05	五线送布牙组件	Five-thread Feed Dog Asm.			1
16	11-80090412-01	螺钉	Screw Sm3/32×56 L=6.5	1	1	1
17	279-05-34	五线主送布牙	Five-thread Main Feed Dog			1
	279-05-34A	三线主送布牙	Three-thread Main Feed Dog	1	1	
18	279-05-33	五线副送布牙	Five-thread Feed Dog			1
	279-05-33A	三线副送布牙	Three-thread Feed Dog	1	1	
19	279-05-28	送布牙底板	Feed Dog Foot	1	1	1
20	279-05-35	五线差动牙	Five-thread Different Feed Dog			1
21	11-40110525-01	螺钉	Presser Seal Screw Sm11/64 ×40 L=5	2	2	2
22	21-04516162-03	垫片	Washer	1	1	1
23	279-05-01	送布轴铜轴承	Feed Shaft Copper Bearing	1	1	1
24	279-05-02	送布曲柄	Feed Shaft Crank	1	1	1
25	279-05-03-00	差动器组件	Differential Feed Asm.	1	1	1
26	279-05-03	差动牙架调整曲柄	Differential Feed Bar Adjusting Crank	<1>	<1>	<1>
27	279-05-40	滑块盖板螺钉	Block Cover Screw Sm1/8×44 L=4.6	<2>	<2>	<2>
28	279-05-05	滑块盖板	Block Thrust Ring	<1>	<1>	<1>
29	279-05-04	滑块	Block	<1>	<1>	<1>
30	279-05-48	差动牙架连杆套螺钉	Differential Feed Bar Connection Link Bushing Screw	1	1	1
31	21-04615122-02	差动牙架连杆套垫圈	Differential Feed Bar Connection Link Bushing Washer	1	1	1
32	279-05-23	差动牙架连杆	Differential Feed Bar Connection Link	1	1	1
33	279-05-24	差动牙架连杆套	Differential Feed Bar Connection Link Bushing	1	1	1
34	279-05-12	油封	Oil Seal	1	1	1
35	11-10080620-01	挡板螺钉	Screw Sm1/8×44 L=6	1	1	1
36	279-05-16	差动送布挡圈	Differential Feed Thrust Ring	1	1	1
37	279-05-15	差动送布滑块	Differential Feed Block	1	1	1
38	279-05-14	滑块偏心轴	Block Eccentric Shaft	1	1	1
39	11-00111220-01	滑块偏心轴螺钉	Block Eccentric Shaft Screw Sm11/64×40 L=12.3	1	1	1
40	11-90110520-01	滑块轴固定套螺钉	Block Shaft Set Bushing Screw Sm11/64×40 L=5.3	2	2	2
41	279-05-13	滑块轴固定套	Block Shaft Stopper Bushing	1	1	1
42	279-05-18	油封	Oil Seal	1	1	1
43	279-05-32	密封垫	Gasket Washer	2	2	2
44	279-05-22-00	牙架组件	Braces Components	1	1	1
45	279-05-22	差动牙架	Differential Feed Bar	<1>	<1>	<1>
46	279-05-19	送布牙架	Feed Bar Holder	<1>	<1>	<1>
47	279-05-17	油封	Oil Seal	1	1	1
48	279-01-116	螺钉	Screw Sm9/64 ×40 L=8	2	2	2
49	11-90110820-01	六角螺钉	Upper Cover (left) Hexagon Screw Sm11/64 ×40	1	1	1

4. 差动部件 Differential Feed Mechanism Components

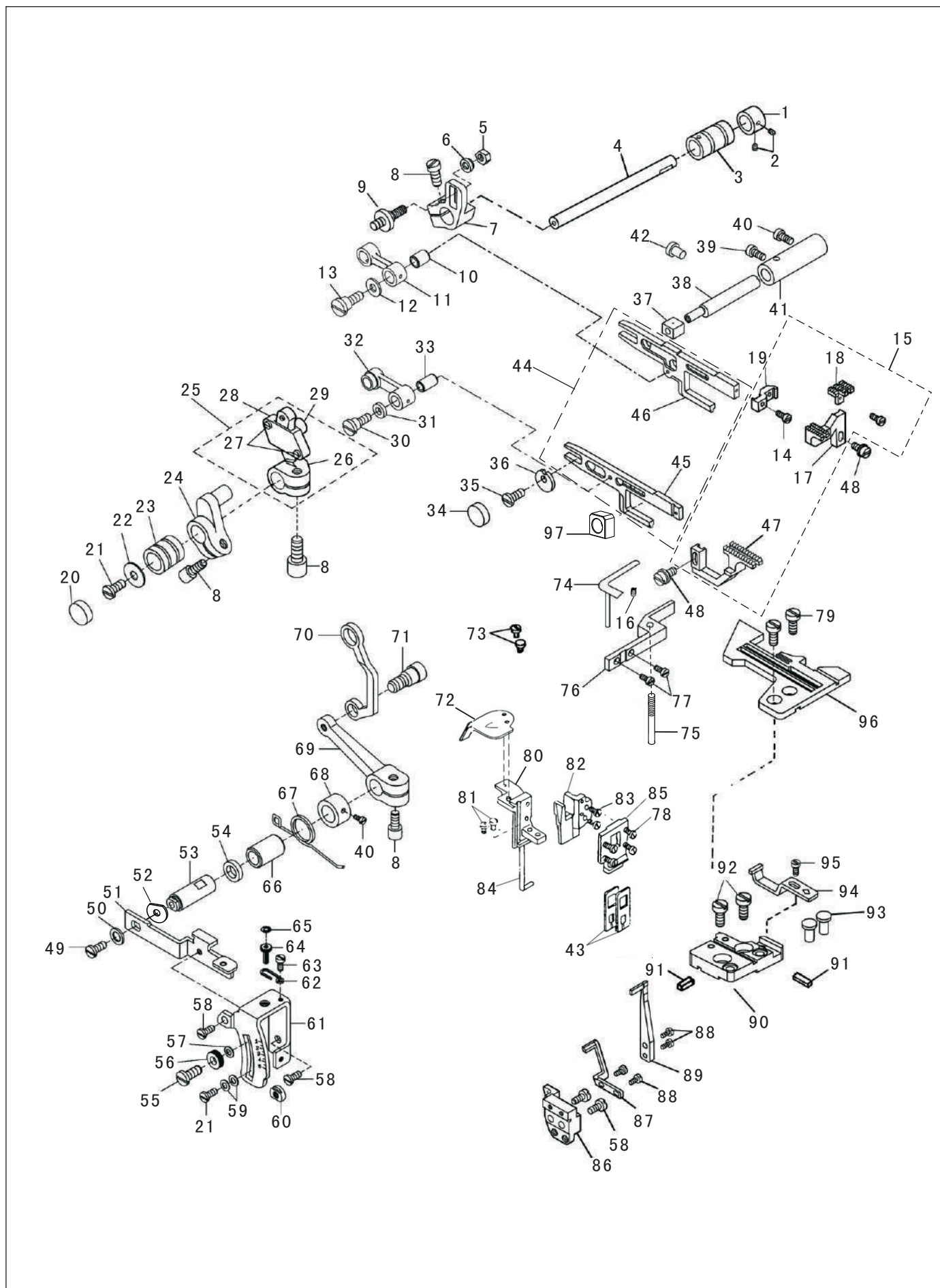

4.差动部件 Differential Feed Mechanism Components

序号 NO.	图号 REF NO.	名称	DESCRIPTION	数量 AMT		
				3线	4线	5线
50	21-04608110-01	调节螺钉垫圈	Regulator Screw Washer	1	1	1
51	279-05-81	差动调节扳手	Differential Regulating Feed Handle	1	1	1
52	2321-05-95	拉杆曲柄垫圈	Pitman Rod Crank Washer	1	1	1
53	279-05-75	拉杆曲柄轴	Pitman Rod Crank Shaft	1	1	1
54	32-09430150-09	油封	Oil Seal	1	1	1
55	279-05-108	手轮螺钉	Hand Wheel Screw	1	1	1
56	279-05-90	手轮	Hand Wheel	1	1	1
57	23-06005120-09	手轮垫片	Washer	1	1	1
58	11-40110825-01D	针距调节指示板螺钉	Needle Gague Regulating Scale Plate Screw Sm11/64×40	2	2	2
59	23-05003090-09	碟形垫圈	Wing Washer	2	2	2
60	279-05-110	调节螺钉螺母	Regulating Screw Nut Sm11/64×40	1	1	1
61	279-05-86	针距调节指示板	Needle Gague Regulating Indicator Plate	1	1	1
62	279-05-89	调节螺栓卡簧	Regulator Bolt Spring	1	1	1
63	11-40080425-01	调节螺栓卡簧螺钉	Regulator Bolt Spring Screw Sm1/8×40 L=4.5	1	1	1
64	279-05-88	调节螺栓手轮钮	Regulator Bolt Hand Wheel Knod	1	1	1
65	279-05-87	标记牌	Marking Card	1	1	1
66	279-05-74	拉杆曲柄铜轴承	Pitman Rod Crank Copper Bearing	1	1	1
67	279-05-76	差动扳手扭簧	Differential Feed Handle Torsion Spring	1	1	1
68	279-05-77	拉杆曲柄轴挡圈	Pitman Rod Crank Shaft Thrust Ring	1	1	1
69	279-05-78	差动调节曲柄	Differentric Regulating Crank	1	1	1
70	279-05-80	差动调节连杆	Differentric Regulating Connection Link	1	1	1
71	279-05-104	轴定螺钉	Cheese Head Set Screw	1	1	1
72	279-01-55	挡油罩	Oil Seal Cover	1	1	1
73	11-10080420-01	挡油罩螺钉	Oil Seal Cover Screw Sm1/8 ×44 L=4	2	2	2
74	279-02-78	针板橡胶垫	Needle Plate Rubber Cushion	1	1	1
75	279-02-96	调节螺钉	Regulating Screw	1	1	1
76	279-02-77	针板支架	Needle Plate Bracket	1	1	1
77	11-90090820-01	六角头螺钉	Hexagon Screw Sm9/64×40 L=7.6	2	2	2
78	11-60080520-01	密封导架螺钉	Gasket Guide Bracket Screw Sm1/8 ×40 L=4.5	4	4	4
79	11-20110920-02	针板螺钉	Needle Guide Screw Sm11/64×40 L=9	2	2	2
80	279-01-54	油封架座	Oil Seal Bracket	1	1	1
81	11-60111020-01	油封架螺钉	Oil Seal Bracket Screw Sm11/64X40 L=10	2	2	2
82	279-05-30	牙架导轨	Feed Bar Guide Rail	1	1	1
83	279-05-50	牙架导轨螺钉	Screw Sm11/64×40 L=8	2	2	2
84	279-05-29	油封	Oil Seal	1	1	1
85	279-05-31	密封导架	Gasket Guide Bracket	1	1	1
86	279-02-84	五线护针板架	Five Thread Needle Thread Guard Bracket			1
	279-02-84A	三、四线护针板架	Three ,four Thread Needle Thread Guard Bracket	1	1	
87	279-02-85	前直针后护针板	Front Needle Back Needle Thread Guard	1	1	1
88	11-40060625-01	护针板螺钉	Needle Thread Guard Screw Sm3/32 ×56 L=6	2	2	4
89	279-02-86	后直针前护针板	Back Needle Front Needle Thread Guard			1
90	2304-04-05	针板座	Needle Plate Bracket	<1>	<1>	<1>
91	279-02-83	针板定位键	Needle Plate Set Key	<2>	<2>	<2>
92	11-40151025-01	针板座固定螺钉	Needle Plate Bracket Fixing Screw Sm15/64 ×28 L=10.6	2	2	2
93	279-02-81	针板座橡胶垫	Needle Plate Bracket Rubber Cushion	2	2	2
94	279-02-82	五线前护针板	Five-thread Front Needle Thread Guard			1
	279-02-82A	三、四线前护针板	Three、 four-thread Front Needle Thread Guard	1	1	
95	11-40090625-01	前护针板螺钉	Front Needle Thread Guard Screw Sm9/64 ×40 L=5.5	1	1	1
96	279-02-79	五线针板	Five-thread Needle Plate			1
	279-02-79A	四线针板	Four-thread Needle Plate		1	
	279-02-79B	三线针板	Three-thread Needle Plate	1		
97	279-05-25B	拾牙滑块	Feed Bar Liffer Block	1	1	1

5.上下切刀部件 Upper & Lower Knife Components

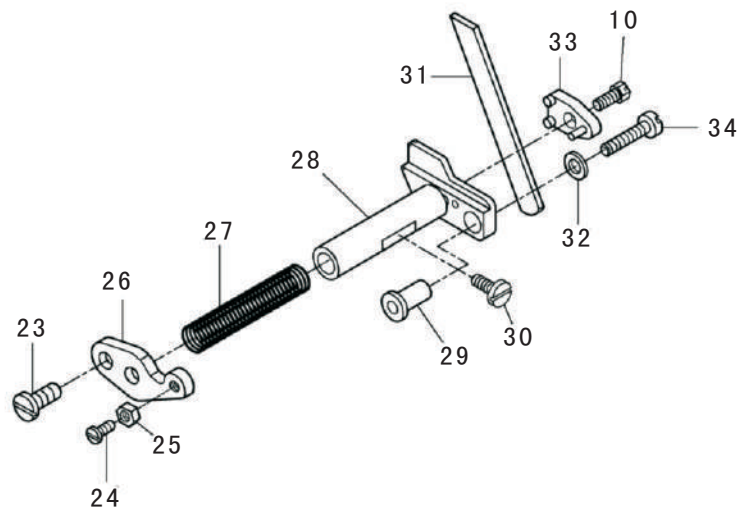
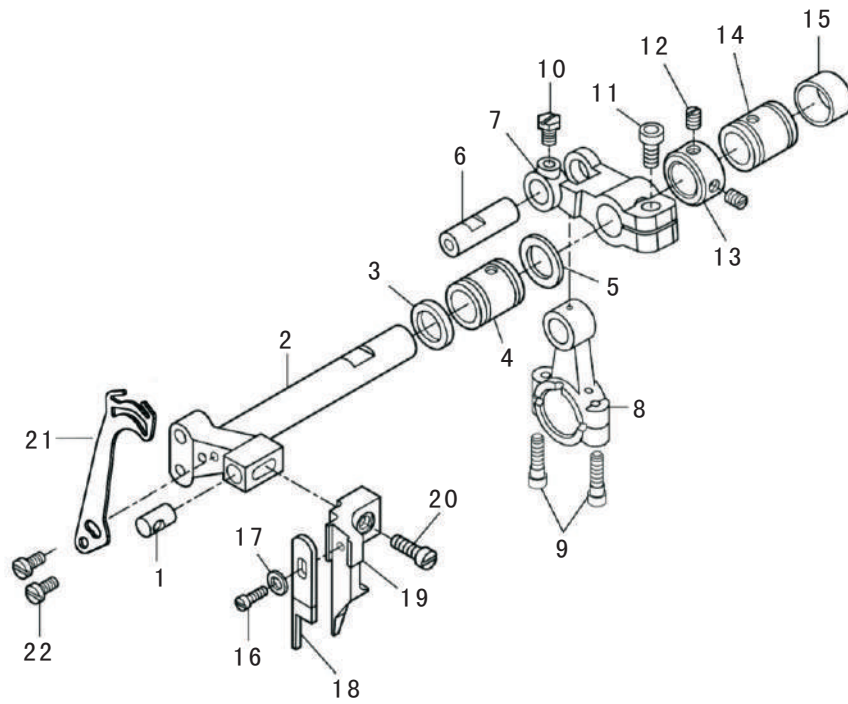

5.上下切刀部件 Upper & Lower Knife Components

序号 NO.	图号 REF NO.	名称	DESCRIPTION	数量 AMT		
				3线	4线	5线
1	279-06-10	短销	Short Pin	1	1	1
2	279-06-06	上切刀摆轴	Upper Knife Rock Shaft	1	1	1
3	32-11530170-09	油封	Oil Seal	1	1	1
4	279-06-02	上切刀摆轴右铜轴承	Upper Knife Rock Shaft Right Copper Bearing	1	1	1
5	21-12115192-03	垫片	Washer	1	1	1
6	279-06-05	上切刀曲柄销	Upper Knife Crank Pin	1	1	1
7	293-05-02	上切刀传动曲柄	Upper Knife Driving Crank	1	1	1
8	2321-06-04	上切刀传动连杆	Upper Knife Connection Link	<1>	<1>	<1>
9	11-40091225-01	螺钉	Upper Looper Washer Sm9/64 ×40 L=12	2	2	2
10	11-90110820-01	开槽六角螺钉	Hexagon Snap Screw Sm11/64×40 L=8	2	2	2
11	11-60151522-01	圆柱头内六角螺钉	Cheese Head Hexagonal Socket Set Screw Sm15/64×28 L=15	1	1	1
12	11-00140710-01	挡圈紧定螺钉	Thrust Ring Set Screw Sm7/32×32 L=6.4	2	2	2
13	279-06-07	上切刀摆轴挡圈	Upper Knife Rock Shaft Thrust Ring	1	1	1
14	279-06-08	上切刀摆轴铜轴承	Upper Knife Rock Shaft Copper Bearing	1	1	1
15	279-06-09	油封	Oil Seal	1	1	1
16	11-90090820-01	六角头螺钉	Hexagon Screw Sm9/64×40 L=7.6	1	1	1
17	21-03810080-01	垫圈	Washer	1	1	1
18	279-06-12	上切刀	Upper Knife	1	1	1
19	279-06-11	上切刀架	Upper Knife Bracket			1
	279-06-11A	三、四线上切刀架	Three、 four-thread Upper Knife Bracket	1	1	
20	11-40110825-01	上切刀架紧固螺钉	Upper Knife Bracket Fixing Screw Sm11/64×40 L=8	1	1	1
21	2320-05-01-01	挑线钩（五线）	Five Thread Upper Take -up Guide			1
	2320-05-01	挑线勾（四线）	Four Thread Upper Take -up Guide		1	
	2320-05-01-02	挑线勾（三线）	Three Thread Upper Take -up Guide	1		
22	11-40090625-01	上挑线勾固定螺钉	Upper Take -up Hook Fixing Screw Sm9/64 ×40 L=5.5	2	2	2
23	11-40110525-01	固定螺钉	Fixing Screw Sm11/64 ×40 L=7	1	1	1
24	11-40090825-01D	调节螺钉	Regulating Screw Sm9/64 ×40 L=8	1	1	1
25	13-60093020-01	螺母	Nut Sm9/64 ×40	1	1	1
26	279-01-47	固定板	Set Plate	1	1	1
27	279-06-13	下切刀弹簧	Knife Bottom Spring	1	1	1
28	279-06-14	下切刀架	Knife Bottom Bracket			1
	279-06-14A	下切刀架	Knife Bottom Bracket	1	1	
29	279-06-15	定位套筒	Stopped Bushing	1	1	1
30	11-40111225-01	下切刀架紧定螺钉	Knife Bottom Bracket Set Screw Sm11/64×40 L=8	1	1	1
31	279-06-16	下切刀	Knife Bottom	1	1	1
32	21-04608110-01	垫圈	Washer	1	1	1
33	279-06-17	下切刀压板	Knife Bottom Presser Plate	1	1	1
34	11-60112620-01	下切刀架调节螺钉	Knife Bottom Bracket Adjusting Screw Sm11/64×40	1	1	1
35	209-05-09	铜垫片				

6.上下弯针部件 Upper & Lower Loper Components

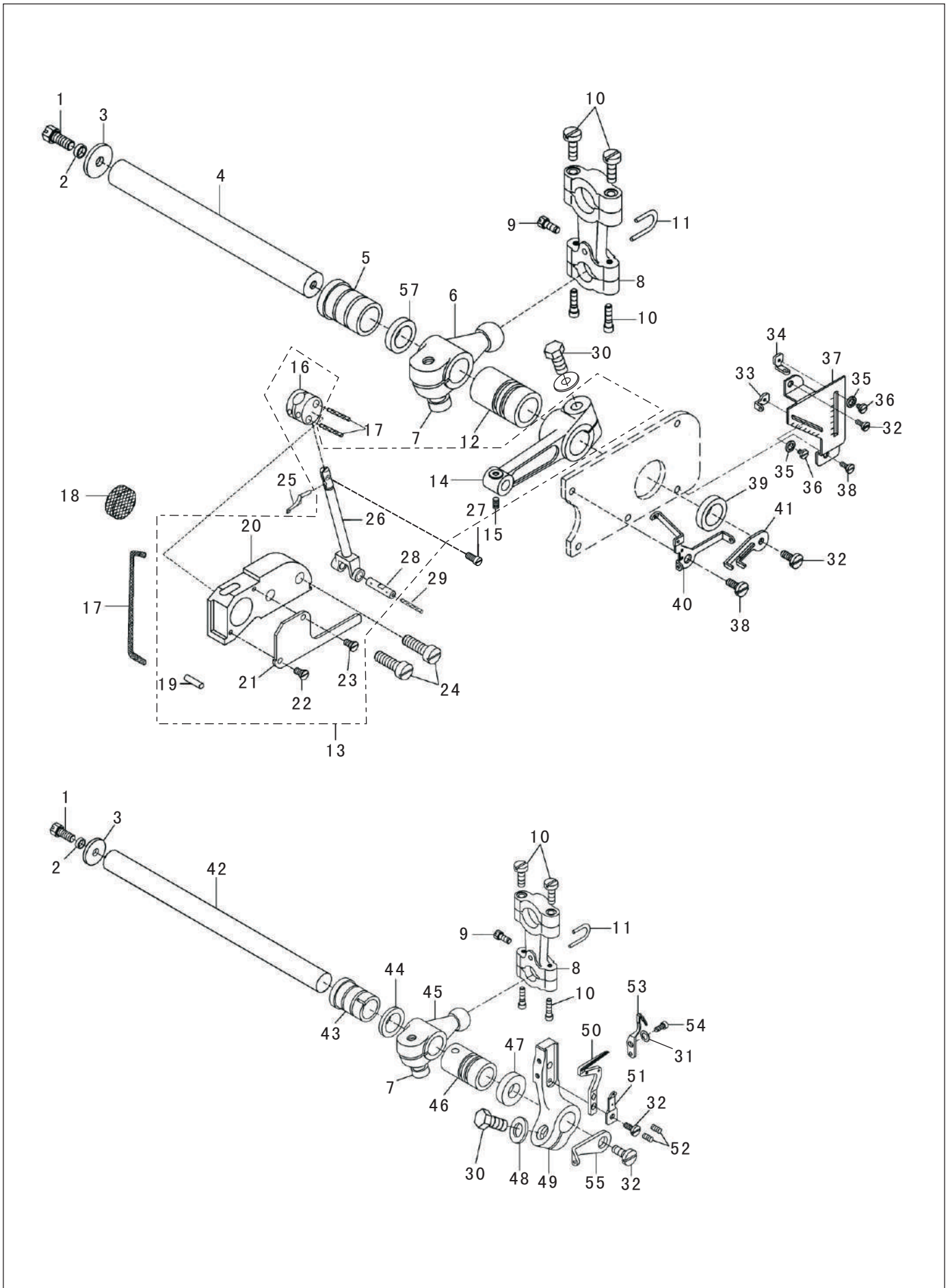

6.上下弯针部件 Upper & Lower Loper Components

序号 NO.	图号 REF NO.	名称	DESCRIPTION	数量 AMT		
				3线	4线	5线
1	11-90110820-01	六角头开槽螺钉	Cheese Head Hexagonal Socket Screw Sm11/64 ×40 L=8	2	2	2
2	22-05000000-08	弹簧垫圈	Washer	2	2	2
3	21-04516162-03	上弯针轴垫圈	Upper Loper Shaft Washer	2	2	2
4	279-03-08	上弯针轴	Upper Loper Shaft	1	1	1
5	2304-06-01	上弯针轴后套	Upper Loper Ball Crank Shaft Back Copper Bearing	1	1	1
6	279-03-04	四五线上弯针球曲柄	Four ,five Thread Upper Loper Ball Crank	<1>	<1>	<1>
7	11-60151422-01	圆柱头内六角螺钉	Thread Guide Washer Sm15/64 ×28 L=14	2	2	1
8	279-03-01	上下弯针球连杆组件	Upper、 lower Loper Ball Rod Complete	<2>	<2>	<2>
9	11-60080620-01	圆柱头螺钉	Cheese Head Set Screw Sm1/8 ×44 L=6	<2>	<2>	<2>
10	11-40091225-01	螺钉	Upper Loper Washer Sm9/64x40 L=12	8	8	8
11	279-03-05	上摆轴	Upper Rock Shaft	<2>	<2>	<2>
12	279-03-03	上弯针球曲柄轴前轴承	Upper Loper Ball Crank Shaft Front Copper Bearing	1	1	1
13	279-03-14-00	上弯针滑块组件	Upper Loper Slide Block Asm.	1	1	1
14	279-03-10	上弯针滑杆连杆	Upper Loper Slide Bar Connection Link	<1>	<1>	<1>
15	11-80080312-01	连杆销固定螺钉	Connection Link Pin Fixing Screw Sm1/8 ×44 L=3	<1>	<1>	<1>
16	203-01-28	上弯针滑杆滑块	Upper Loper Slide Bar Block	<1>	<1>	<1>
17	43-10250000-00	油线	Oil Wick	<0.06>	<0.06>	<0.06>
18	135-10-34	油毡	Oil Seal	1	1	1
19	279-05-63	销子	Feed Eccentric Wheel Pin	1	1	1
20	279-03-14	上弯针滑杆座	Upper Loper Slide Bar Bracket	<1>	<1>	<1>
21	279-03-18	挡料板	Fabric Guide Plate	<1>	<1>	<1>
22	11-10080620-01	拦线板螺钉	Fabric Guide Plate Screw Sm1/8 ×44 L=6	<1>	<1>	<1>
23	11-70080420-01	拦线板螺钉	Fabric Guide Plate Screw Sm1/8 ×44 L=3.5	<1>	<1>	<1>
24	11-40151525-01	上弯针滑杆座轴螺钉	Upper Loper Slide Bar Holder Shaft Screw Sm15/64x28	2	2	2
25	279-03-17	上弯针	Upper Loper	1	1	1
26	279-03-16	上弯针滑杆	Upper Loper Slide Bar	<1>	<1>	<1>
27	11-40090725-01	上弯针紧定螺钉	Upper Loper Set Screw Sm9/64 ×40 L=6.3	1	1	1
28	279-03-11	连杆销轴	Connection Link Pin Shaft	<1>	<1>	<1>
29	43-20300000-00	油线	Oil Wick	<0.015>	<0.015>	<0.015>
30	11-90151523-01	连杆固定螺钉	Connection Link Fixing Screw Sm15/64×28 L=15	2	2	2
31	31-03805080-01	护针螺钉垫片	Spacer	1	1	1
32	11-40110525-01	螺钉	Presser Seal Screw Sm11/64 ×40 L=5	>	>	>
33	279-03-22	右穿线板	Thread Guide (right)	3	3	3
34	279-03-21	左穿线板	Thread Guide (left)	1	1	1
35	21-03405070-01	穿线板垫圈	Connection Rod Washer	1	1	1
36	11-40080425-01	穿线板紧固螺钉	Thread Guide Fixing Screw Sm1/8 ×44 L=3.5	2	2	2
37	279-03-23	线量调节板	Thread Amount Regulation Graduation Plate	2	2	2
38	11-40111025-01D	螺钉	Screw	1	1	1
39	32-11540210-09	油封	Oil Seal	2	2	2
40	279-03-19	三眼过线板	Three-hole Thread Guide	1	1	1
41	279-03-20	双眼过线板	Two-hole Thread Guide	1	1	1
42	279-03-46A	下弯针轴(三、四线)	Lower Loper Shaft	1	1	1
	279-03-46	下弯针轴	Lower Loper Shaft	1	1	
43	2304-06-02	下弯针轴后套	Lower Loper Bracket Shaft Back Copper Bearing	1	1	1
44	279-03-43	垫圈	Lower Loper Shaft Copper Bushing Washer	1	1	
45	279-03-44B	三线下弯针球曲柄	Three-thread Lower Loper Ball Crank	1	1	
46	279-03-45	下弯针架轴前轴承	Lower Loper Bracket Ball Crank Copper Bearing	1	1	1
47	32-09440190-09	油封	Oil Seal	1	1	1
48	21-06112110-01	垫圈	Washer	1	1	1
49	279-03-48	下弯针架	Lower Loper Bracket	1	1	1
50	279-03-50	下弯针	Lower Loper	1	1	1
51	279-03-51	下弯针过线	Lower Loper Thread Guid	1	1	1
52	279-03-49	定位铆钉	Position Rivet	2	2	2
53	279-02-87	后直针后护针板	Back Needle Back Needle Thread Guard	1	1	1
54	11-90091020-01	螺钉	Needle Plate Bracket Set Screw Sm9/64 ×40 L=10	1	1	1
55	279-03-52	过线板	Thread Guide Plate	1	1	1
56	279-03-09	上弯针轴套	The Curved Needle Collar	1	1	1
57	21-03805080-01	护针螺钉垫片		1	1	1

7.前弯针部件(五六线专用) Chain Looper Components(for five & six thread)

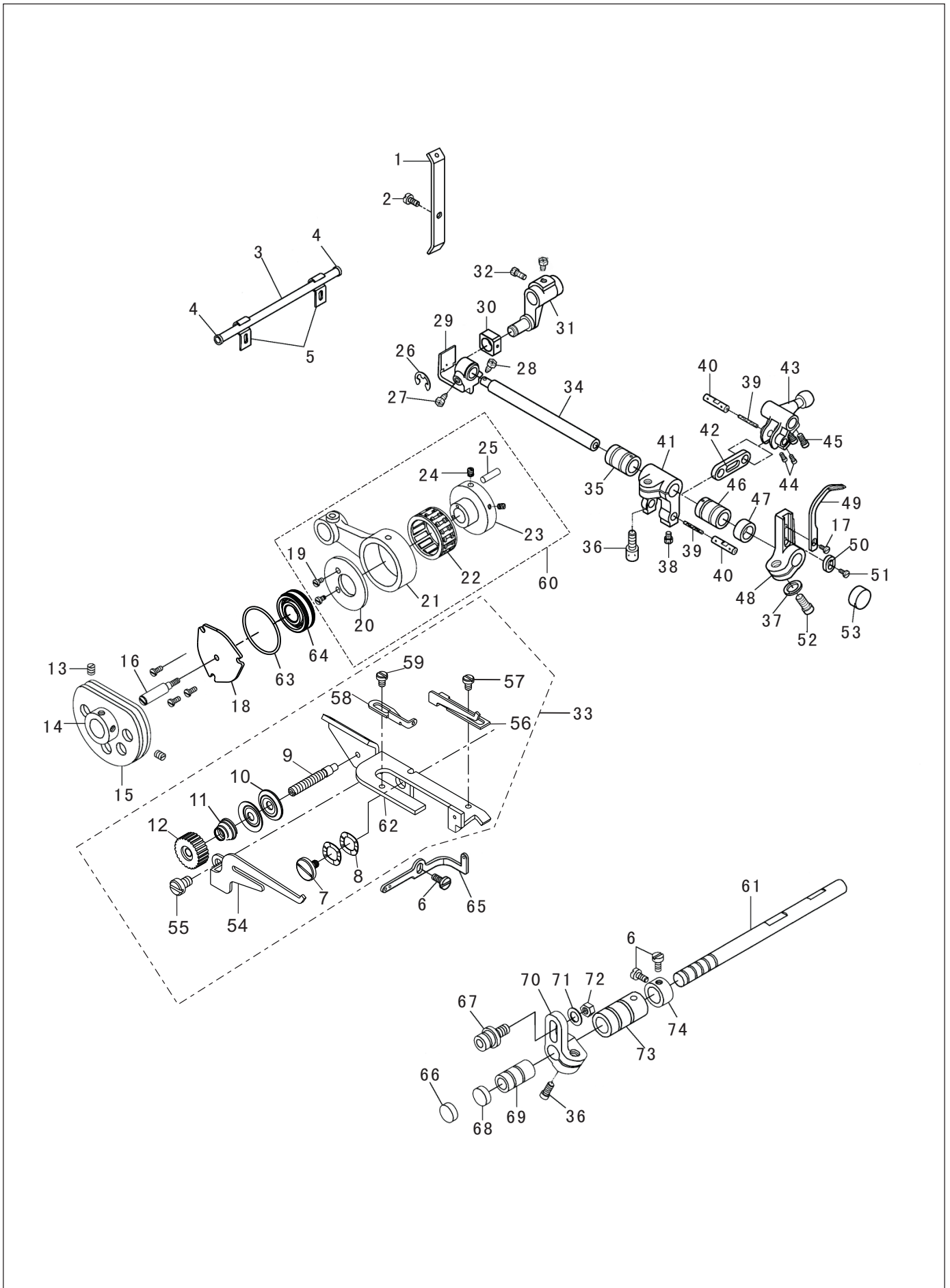

7.前弯针部件(五六线专用) Chain Looper Components(for five & six thread)

序号 NO.	图号 REF NO.	名称	DESCRIPTION	数量 AMT		
				3线	4线	5线
1	279-04-52	前弯针导线板	Front Looper Thread Guide Plate			1
2	11-70110620-02	压线器架螺钉	Thread Guide Bracket Screw Sm11/64x40 L=5.3	1	1	1
3	279-04-53	过线管	Thread Guide Tube			<1>
4	279-04-54	过线管套	Thread Guide Tube Bushing			<2>
5	279-04-55	过线管压板	Thread Guide Tube Presser Plate			2
6	11-40110525-01	螺钉	Screw			5
7	209-03-13	打线凸轮夹线支架螺钉	Screw			1
8	21-06203110-09	弹簧垫片	Washer			1
9	2316-09-21	打线凸轮夹线螺钉	Thread Tension Shaft			1
10	2316-09-22	打线凸轮夹线板	Tension Disc			2
11	2316-09-23	打线凸轮压线簧	Tension Spring			1
12	2316-09-24	打线凸轮夹线螺母组件	Thread Tension Nut Ass'y			1
13	11-80080312-01	凸轮固定螺钉	Cam Fixing Screw Sm1/8x44 L=3			2
14	279-04-43	凸轮轴套	Cam Bushing			<1>
15	279-04-42	张力变换凸轮	Thread Tension Change Cam			<1>
16	2321-04-41	凸轮轴	Cam Shaft			1
17	279-01-116	螺钉	Front Bearing Bracket Screw Sm9/64 x40 L=8			1
18	2316-03-05A	主轴左轴承密封盖	Sealed Cap			1
19	11-20060420-01	挡圈螺钉	Thrust Ring Screw Sm3/32x56 L=3.8			(2)
20	279-05-61	横轴曲柄连杆挡圈	Lateral Crank Connection Link Thrust Ring			(1)
21	279-04-31	横轴曲柄连杆	Lateral Crank Connection Rod			(1)
22	279-04-32	横轴连杆滚针轴承	Lateral Connection Rod Needle Bearing			(1)
23	2304-07-01	送布偏心轮	Feed Eccentric Wheel			(1)
24	11-80110512-01	紧定螺钉	Worm Set Rivet Sm11/64 x40 L=5			(2)
25	279-05-63	销子	Feed Eccentric Wheel Pin			(1)
26	279-04-12	前弯针曲柄挡圈	Front Looper Crank Thrust Ring			1
27	11-90111140-01	驱动座固定螺钉	Driving Bracket Fixing Screw Sm11/64x40 L=10.8			1
28	11-80110652-01	驱动座固定螺钉	Driving Bracket Fixing Screw Sm11/64x40 L=6.3			1
29	279-04-10	驱动座	Driving Bracket			1
30	279-04-11	前弯针滑块	Front Looper Block			1
31	279-04-35	驱动曲柄	Driving Crank			1
32	11-90110520-01	螺钉	Thrust Ring Screw Sm11/64x40 L=5.3			2
33	2316-09-20-00	打线凸轮夹线支架组件	Looper Thread Guide Ass'y			1
34	279-04-09	前弯针轴	Front Looper Shaft			1
35	279-04-01	前弯针纵轴后轴承	Front Looper Lengthwise Shaft Back Copper Bearing			1
36	11-60151522-01	圆柱头内六角螺钉	Cheese Head Hexagonal Socket Screw Sm15/64x28			2
37	21-06112110-01	垫圈	Washer			3
38	11-40110825-01D	螺钉	Upper Cover (left) Fixing Screw Sm11/64 x40 L=8			1
39	43-20300000-00	油线	Oil Wick			0.028
40	279-04-08	前弯针连杆销	Front Looper Lever Pin			2
41	279-04-02	前弯针曲柄	Front Looper Crank			1
42	279-04-07	前弯针连杆	Front Looper Lever			1
43	279-03-44	下弯针轴球曲柄	Lower Looper Shaft Ball Crank			<1>
44	11-40090725-01	圆柱头螺钉	Cheese Head Screw Sm9/64x40 L=7.8			2
45	11-60160852-01	内六角螺钉	Hexagonal Socket Screw Sm1/4x40 L=8			2
46	279-04-33	前弯针纵轴前轴承	Front Looper Lengthwiseshaft Front Copper Bearing			1
47	32-09440190-09	油封	Oil Seal			1
48	279-04-05	前弯针架	Front Looper Bracket			1
49	279-04-06	前弯针	Front Looper			1
50	279-04-15	前弯针调节垫片	Front Looper Adjusting Washer			1
51	11-60060520-01	前弯针定位螺钉	Front Looper Set Screw Sm3/32x56 L=5			1
52	11-90151323-01	前弯针架紧固内六角螺钉	Front Looper Bracket Fixing Hexagonal Socket Screw			1

7.前弯针部件(五六线专用) Chain Looper Components(for five & six thread)

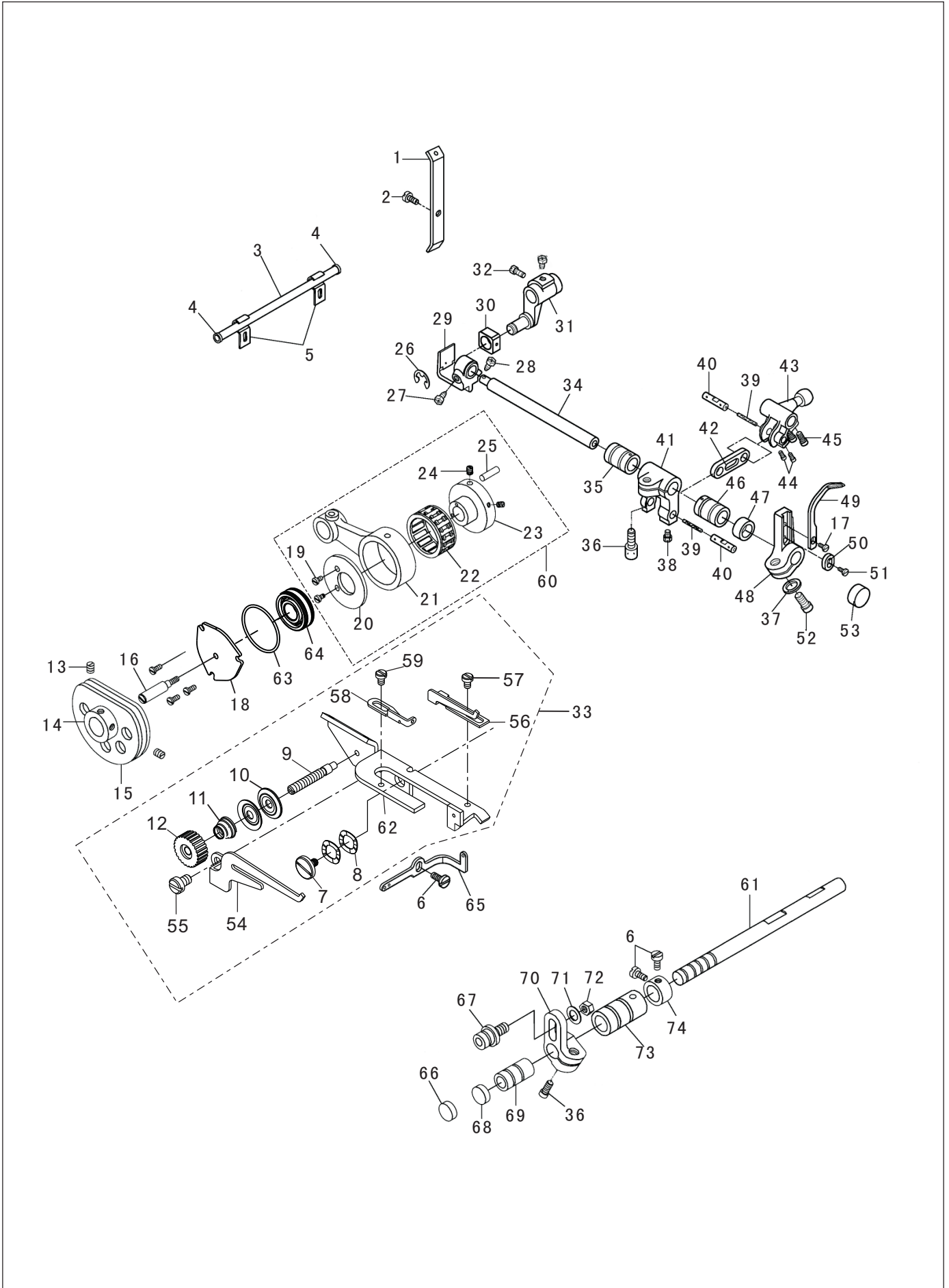

7.前弯针部件(五六线专用) Chain Looper Components(for five & six thread)

序号 NO.	图号 REF NO.	名称	DESCRIPTION	数量 AMT		
				3线	4线	5线
53	279-04-23	三、四线油封	Three Or Four-thread Oil Seal	1	1	
54	2316-09-25	打线凸轮分线板	Looper Thread Guide A			1
55	12-60400520-01	打线凸轮分线板螺钉	Screw			1
56	2316-09-26	打线凸轮右过线勾	Looper Thread Guide B			1
57	12-60300420-01A	打线凸轮右过线勾螺钉	Screw			1
58	2316-09-27	打线凸轮左过线勾	Looper Thread Guide C			1
59	12-60300420-01A	打线凸轮左过线勾螺钉	Screw			1
60	11-20060420-01	前弯针偏心轮组件				1
61	279-04-39	前弯针横轴	Front Looper Lateral Shaft			1
62	2316-09-20	打线凸轮夹线支架	Looper Thread Guide			1
63	31-04020000-09	主轴左轴承O型圈	O Ring	1	1	1
64	2316-03-06	主轴左轴承组件	Ball Bearing Ass'y	1	1	1
65	279-04-45	二眼过线	Two-hole Thread Guide			
66	279-05-17	油封	Oil Seal	1	1	1
67	279-04-38	曲柄销	Crank Pin			1
68	279-04-40	油封	Oil Seal			1
69	279-04-33	前弯针横轴铜轴承	Front Looper Lateral Shaft Front Copper Bearing			1
70	279-04-34	横轴曲柄架	Lateral Crank Bracket			1
71	21-06510120-01	曲柄调整销垫圈	Crank Regulating Pin Washer			1
72	13-60145520-01	曲柄调整销螺母	Crank Regulating Pin Nut Sm7/32×32			1
73	279-04-36	前弯针横轴前铜轴承	Front Looper Lateral Shaft Front Copper Bearing (right)			1
74	279-04-37	横轴挡圈	Lateral Thrust Ring			1
75	2304-07-01-00	前弯针偏心轮组件				

8.抬压脚部件 Presser Foot Lifter Components

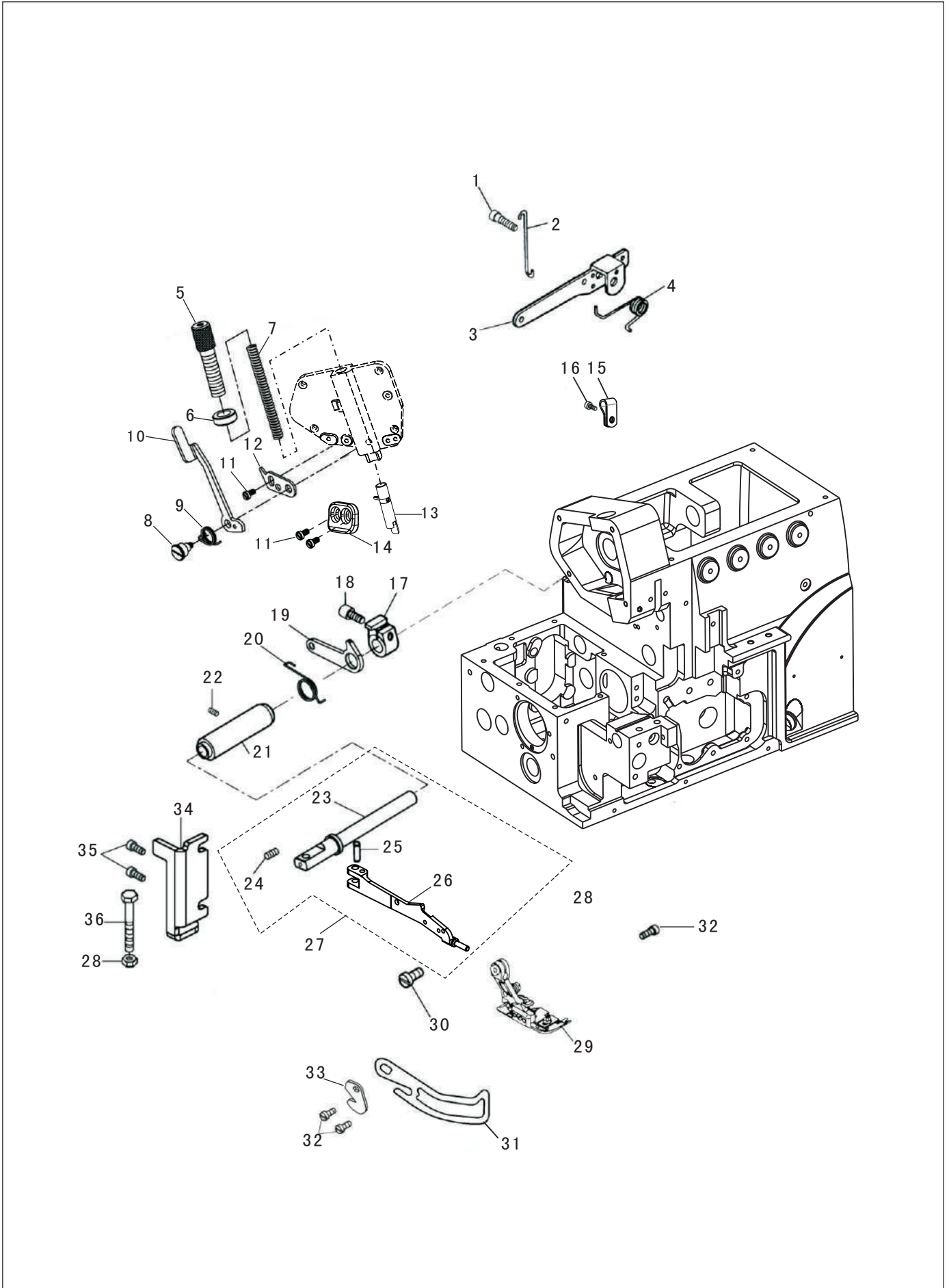

8.抬压脚部件 Presser Foot Lifter Components

序号 NO.	图号 REF NO.	名称	DESCRIPTION	数量 AMT		
				3线	4线	5线
1	279-07-30	抬压脚杠杆轴位螺钉	Presser Foot Lifting Lever Link Cheese Head Set Screw	1	1	1
2	279-07-21	吊钩	Presser Foot Lifting Hook	1	1	1
3	279-07-19	抬压脚杠杆	Pressed Foot Lifting Lever Link	1	1	1
4	279-07-20	杠杆弹簧	Presser Foot Lifting Lever Link Spring	1	1	1
5	2316-12-09	调压螺钉	Screw	<1>	<1>	<1>
6	2316-12-10	调压螺钉锁紧螺母	Nut	<1>	<1>	<1>
7	2316-12-08	调压簧	Pressure Regulating Spring	1	1	1
8	209-12-27	抬压板手轴位螺钉	Screw	1	1	1
9	209-12-26	抬压板手复位扭簧	Lifting Clamp Hand Reset Torsion Spring	1	1	1
10	2316-12-11	抬压板手	Lifting Clamp Hand	1	1	1
11	12-40400825-01	抬压板手限位板螺钉	Screw	1	1	1
12	2320-08-05	抬压板手限位板	Lifting Clamp Hand Limit Board	1	1	1
13	2321-08-08	压紧杆组件	Presser Bar Assy.	1	1	1
14	2320-08-04	LED灯	Led Lights	1	1	1
15	501-13-05-09	电缆夹	Cable Clip	3	3	3
16	12-40400525-01	螺钉	Screw	3	3	3
17	209-12-06	抬压脚曲柄	Lifting Presser Foot Shaft Lever	1	1	1
18	12-60601422-01	螺钉	Screw M6 L=14	1	1	1
19	2310-08-09	抬压脚轴扛杆	Ks214	1	1	1
20	2304-08-01	抬压脚轴扛杆簧	Presser Foot Shaft Lever Spring	1	1	1
21	2321-08-14	压脚轴套	Presser Foot Shaft Bushing	1	1	1
22	11-80110412-01	压脚轴套固定螺钉	Presser Foot Shaft Bushing Fixing Screw Sm11/64×40	1	1	1
23	2321-08-01	抬压脚轴	Presser Foot Shaft	1	1	1
24	11-80090412-01	螺钉	Hinge Pin Screw Sm9/64 ×40 L=4	1	1	1
25	293-08-19	抬压脚销	Presser Foot Lifting Pin	1	1	1
26	2321-08-02	压脚臂	The Presser Foot Arm	1	1	1
27	2321-08-01-00	抬压脚臂组件	Presser Foot Arm Ass'y	1	1	1
28	14-60504020-01	螺母	Nut	1	1	1
29	2310-08-12-00	压脚组件	Presser Foot Complete			1
	2310-08-14-00	压脚组件	Presser Foot Complete		1	
	2310-08-13-00	压脚组件	Presser Foot Complete	1		
30	279-07-40	螺钉	Screw Sm9/64×40 L=6.5	<1>	<1>	<1>
31	2320-08-03	护指器	Refers To The Guard	1	1	1
32	11-40080425-01D	螺钉	Spring Stopper Screw Sm1/8×44 L=4	3	3	3
33	279-07-15	割线刀	Thread Cutter	1	1	1
34	2310-08-07	杠杆限位座	Leverage Limit Seat	1	1	1
35	11-40111025-01D	螺钉	Screw	2	2	2
36	12-60501820-01	抬压脚杠杆定位螺钉	Screw	1	1	1

9. 供油部件 Lubrication Mechanism Components

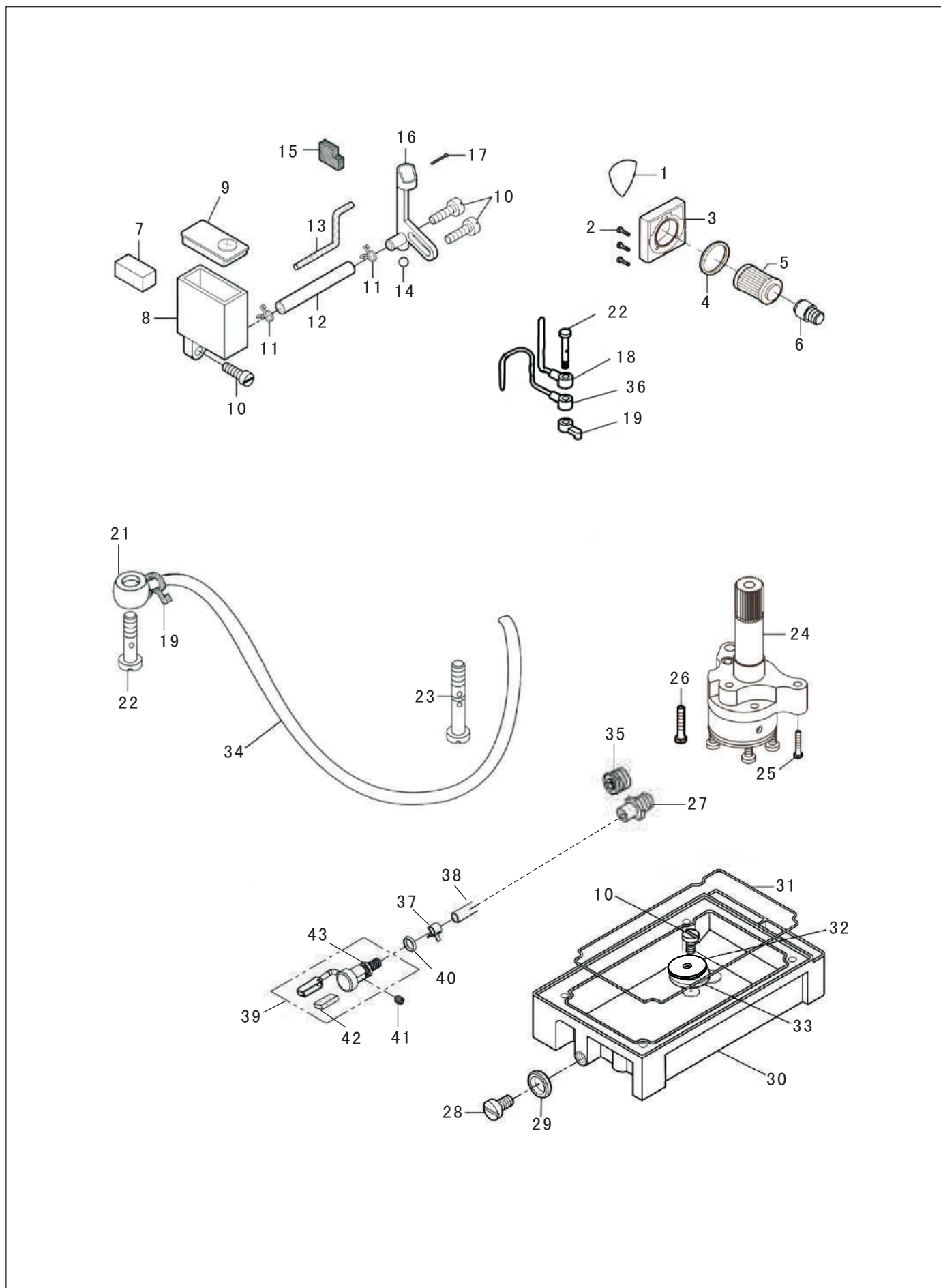

9.供油部件 Lubrication Mechanism Components

序号 NO.	图号 REF NO.	名称	DESCRIPTION	数量 AMT		
				3线	4线	5线
1	44-0000008-00	指示牌	Indicator Plate	1	1	1
2	11-40111525-01	滤油器盖固定螺钉	Oil Filter Cover Fixing Screw Sm11/64×40 L=15	3	3	3
3	301-17-14	滤油器盖	Oil Filter Cover	1	1	1
4	31-39035000-09	油封	Oil Seal	1	1	1
5	279-08-23	纸质滤油器	Space Oil Cleaner	1	1	1
6	279-08-22	滤油器定位接头	Oil Filter Positioning Connectors	1	1	1
7	279-09-12	滤油毡	Filter Felt	1	1	1
8	279-09-11	小油箱	Small Tank	1	1	1
9	279-09-13	小油箱盖	Small Caps	1	1	1
10	11-40110825-01D	固定螺钉	Screw	4	4	4
11	279-09-10	油管卡簧	Tubing Crad Spring	2	2	2
12	42-07005000-00	油管	Oil Tube	0.05	0.05	0.05
13	43-20300000-00	油线	Filter Oil Seal	0.05	0.05	0.05
14	279-09-19	钢球	Small Oil Tank	1	1	1
15	279-09-08	油毡	Small Oil Tank Cover			1
	279-09-08B	油毡	Small Oil Tank Cover	1	1	
16	279-09-07	机针冷却器	Needle Cooler			1
	279-09-07B	三、四线机针冷却器	Three、four-thread Needle Cooler	1	1	
17	279-09-20	大头针	Pin	1	1	1
18	279-08-17	紫铜油管	Copper Oil Tube	1	1	1
19	279-08-16	油管固定套	Oil Tube Set Bushing	1	1	1
20	279-08-18	紫铜油管	Copper Oil Tube	1	1	1
21	301-16-21	管头	Tube Head	3	3	3
22	279-08-21	铜油管连接螺栓	Copper Oil Tube Connection Bolt	1	1	1
23	279-08-15	油管连接螺钉（双孔）	Screw	1	1	1
24	279-08-01-00	油泵组件	Oil Pump Components	1	1	1
25	279-08-10	螺钉	Screw	1	1	1
26	11-60152220-01	螺钉	Screw	1	1	1
27	2316-13-25-01	油泵体出油接头螺钉	Screw	1	1	1
28	11-70241220-01	螺钉	Screw	1	1	1
29	279-08-34	油封	Oil seal	1	1	
30	279-08-33	油盘	Oil reservoir	1	1	1
31	279-08-30	油盘油封	Oil reservoir gasket	1	1	1
32	21-05520250-03	平垫圈	Flat washer	1	1	1
33	279-08-31	磁铁	Magnet	1	1	1
34	42-07005000-00	油管组件	Tubing assembly	1	1	1
35	12-80600612-01	油泵堵油螺钉	Joint	1	1	1
36	279-08-18	紫铜油管	Copper Oil Tube	1	1	1
37	2316-02-38	针杆回油管夹	Clamp	2	2	2
38	2316-02-39-02	针杆回油管	Tube	1	1	1
39	2316-13-20	针杆回油嘴	Joint	1	1	1
40	31-06819000-09	针杆回油嘴O型圈	O Ring	1	1	1
41	12-80400412-01	供油管组件紧固螺钉	Screw	1	1	1
42	2316-13-21	针杆回油嘴油毡	Felt	1	1	1
43	510-10-14	回油嘴螺钉	Screw	1	1	1

10.附件 Accessories Components

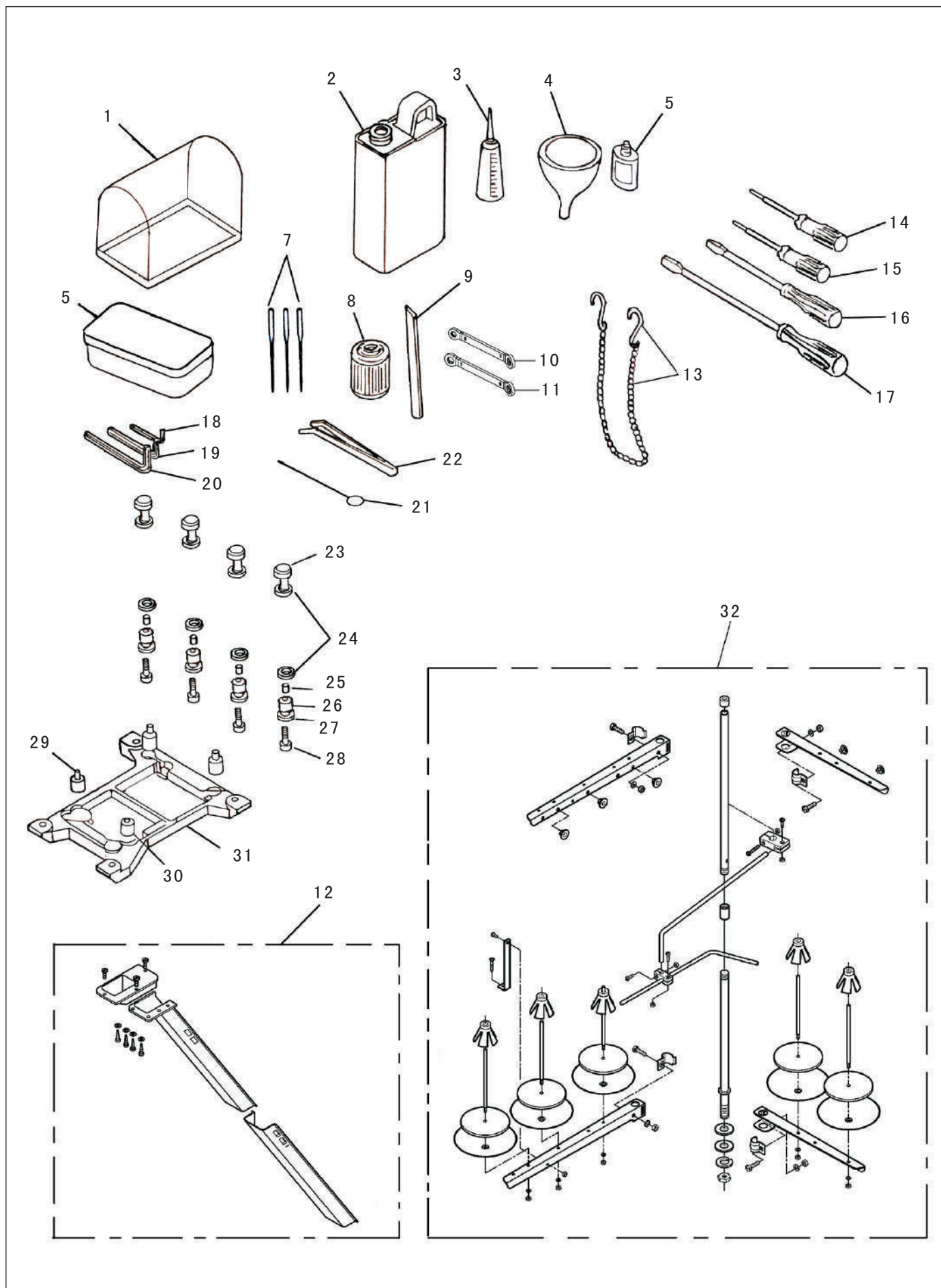

10.附件 Accessories Components

序号 NO.	图号 REF NO.	名称	DESCRIPTION	数量 AMT		
				3线	4线	5线
1	279-11-31	附件箱	Safety Bushing	1	1	1
2	101-12-21	大油壶	Oil Pot	1	1	1
3	279-11-18	小油壶	Small Oil Pot	1	1	1
4	279-11-17	漏斗	Filler	1	1	1
5	120-09-06	硅油壶	Silicone Oil Box	1	1	1
	279-11-19-01	硅油壶橡胶塞	Silicone Oil Pot Of Rubber Plug	1	1	1
6	279-11-20	附件袋	Accessories Box	1	1	1
7	279-02-30	DC×27 11#机针	11# Needle	3	3	
	279-02-30A	DC×27 14#机针	14# Needle			3
8	279-08-23	纸质滤油器	Space Oil Cleaner	1	1	1
9	279-06-16	下切刀	Knife Bottom	1	1	1
10	2304-11-01	梅花型双头扳手 (6-7)	Two-head Driver	1	1	1
11	2304-11-02	梅花型双头扳手 (7-8)	Two-head Driver	1	1	1
12	279-11-08-00	废料漏斗组件	Flot Sam.	1	1	1
13	279-11-12	链条	Chain	<1>	<1>	<1>
	279-11-11	链条钩	Hook	<2>	<2>	<2>
14	279-11-29	内六角扳手 (1.5)	Hexagon Wrench (1.5)	1	1	1
	279-11-27	内六角扳手 (1.6)	Hexagon Wrench (1.6)	1	1	1
15	279-11-28	内六角扳手 (2)	Hexagon Wrench (2)	1	1	1
16	101-12-16	螺丝刀 (中)	Screw Driver (middle)	1	1	1
17	101-12-15	螺丝刀 (大)	Screw Driver (large)	1	1	1
18	301-20-26	内六角扳手 (3)	Hexagon Wrench (3)	1	1	1
19	301-20-29	内六角扳手 (5)	Hexagon Wrench (5)	1	1	1
20	301-20-30	内六角扳手 (6)	Hexagon Wrench (6)	1	1	1
21	279-11-21	线勾	Stitch Hook	1	1	1
22	279-11-24	镊子	Tweezer	1	1	1
23	279-11-02	托盘固定螺套	Bracket Plate Set Bolt	4	4	4
24	279-11-05-02	托盘垫片	Washer	8	8	8
25	279-11-04	台板托盘连接内垫	Lifter Table Bracker Plate Connecting Inner Washer	4	4	4
26	279-11-03	台板托盘连接垫	Lifter Table Bracket Plate Connecting Washer	4	4	4
27	279-11-05-01	托盘连接垫片	Bracket Plate Washer	4	4	4
28	279-11-05	托盘螺钉	Bracket Plate Screw	4	4	4
29	279-11-06	机头防震销垫片	Machine Head Shockproof Pin Washer	3	3	3
30	279-11-07	机头防震垫	Machine Head Shockproof Washer	1	1	1
31	279-11-01	抬板托盘	Lifter Table Bracket Plate	1	1	1
32	279-12-05	五线架组件	Five-thread Standing Device Asm.			1
	279-12-04	四线架组件	Four-thread Standing Device Asm.		1	
	279-12-03	三线架组件	Three-thread Standing Device Asm.	1		
33	293-03-33-02-2	控制器开关小组件				
34	293-10-01-01	上泡沫				
35	293-10-01-02	下泡沫				
36	279-11-26	尼龙袋				
37	279-11-30	757机头纸箱				
	279-11-30-1	7720机头中性纸箱				
38	197-104-001	干燥剂				
39	179-06-2304	皮带 (M34)				
40	2321-01-21	说明和零件样本				
41	52-7720-100	说明和零件样本 (上工)				

11.直驱部件 Direct Drive Components

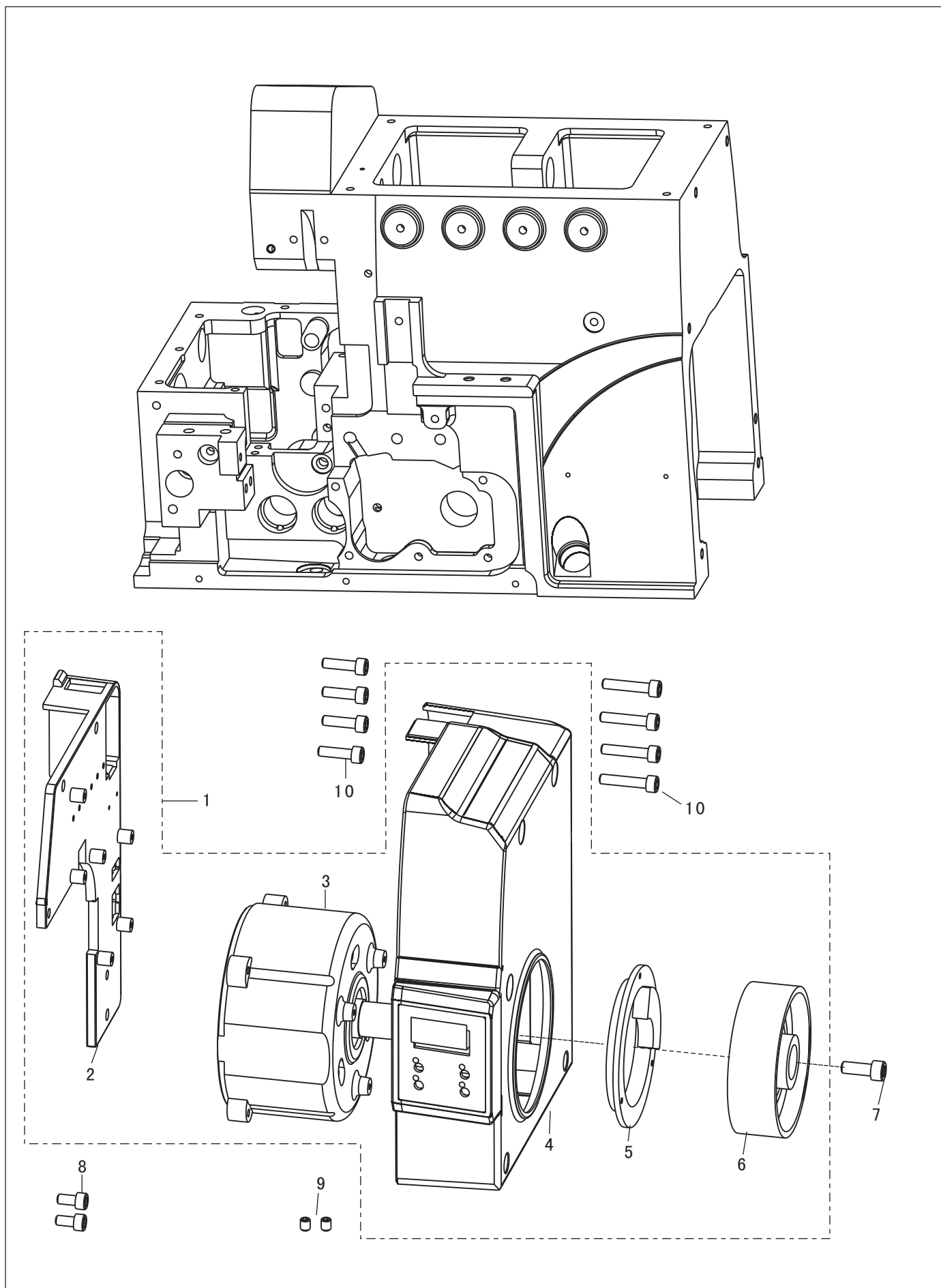

11.直驱部件 Direct Drive Components

序号 NO.	图号 REF NO.	名称	DESCRIPTION	数量 AMT		
				3E	4E	5E
1	2321-11-03	直驱电机电控组件	Motor Electric Control Ass'y	1	1	1
2	2321-11-03-01	主板支架	Motherboard Bracket	<1>	<1>	<1>
3	2321-11-03-02	直驱电机	Direct Drive Motor	<1>	<1>	<1>
4	2321-11-03-03	电机罩壳	Motor Housing	<1>	<1>	<1>
5	2321-11-03-04	传感器	Inductor	<1>	<1>	<1>
6	2321-11-03-05	手轮	Handle Wheel	<1>	<1>	<1>
7	11-60151822-01	SM15/64×28螺钉	Screw SM15/64×28	1	1	1
8	12-60501022-01	M5×10螺钉	Screw M5×10	4	4	4
9	12-80500622-01	螺丝	Screw	2	2	2
10	12-60502022-01	M5×20螺钉	Screw M5×20	8	8	8
11	1280-02-11	单剪线系统说明书				
	1280-02-11A	剪线系统说明（中性）				
	1280-01-11C	使用说明书（GEMSY）				
	1280-01-11D	使用说明书（无牌）				
12	1224-01-04	橡胶塞				

GEMSY

© 2016 Copyright Zhejiang Shangong Gemsy Sewing Technology Co., Ltd

P/N. 1.17.02.07.028 Rev01-2016